

SULIT



**BAHAGIAN PEPERIKSAAN DAN PENILAIAN
JABATAN PENDIDIKAN POLITEKNIK
KEMENTERIAN PENDIDIKAN TINGGI**

JABATAN KEJURUTERAAN MEKANIKAL

PEPERIKSAAN AKHIR

SESI JUN 2016

JJ310 STRENGTH OF MATERIAL

TARIKH : 22 OKTOBER 2016

TEMPOH : 8.30 AM – 10.30 AM (2 JAM)

Kertas ini mengandungi **SEMBILAN (9)** halaman bercetak.

Struktur (6 Soalan)

Dokumen sokongan yang disertakan : Tiada

JANGAN BUKA KERTAS SOALAN INI SEHINGGA DIARAHKAN

(CLO yang tertera hanya sebagai rujukan)

SULIT

INSTRUCTION:

This section consists of **SIX (6)** questions. Answer **FOUR (4)** questions.

ARAHAN:

Bahagian ini mengandungi ENAM (6) soalan. Jawab EMPAT (4) soalan.

QUESTION 1**SOALAN 1**

CLO 1
C1

- a) State **TWO (2)** reasons why Tensile testing is important in engineering field.

Nyatakan DUA (2) sebab Ujian Tegangan penting dalam bidang kejuruteraan.

[2 marks]

CLO 1
C3

- b) Sketch a stress versus strain graph for mild steel after tensile testing.

Lakarkan graf tegasan melawan keterikan bagi keluli lembut selepas menjalani ujian tegangan.

[5 marks]

[5 markah]

CLO 1
C3

- c) A tensile test is performed on a brass specimen 10 mm in diameter using a gauge length of 50 mm. When the tensile load P reaches a value of 20 kN, the distance between the gauge marks has increased by 0.122 mm. Calculate :

Satu Ujian tegangan dilakukan pada spesimen loyang berdiameter 10mm dan panjang tolok adalah 50 mm. Apabila beban tegangan mencapai 20 kN, jarak panjang tolok bertambah sebanyak 0.122 mm. Kirakan :

- i. Modulus of Elasticity, E of the brass

Modulus Keanjalan, E bagi tembaga

[12 marks]

[12 markah]

- ii. Poisson 's ratio, if the diameter of gauge decreases by 0.00830 mm.

Nisbah Poisson, sekiranya diameter tolok berkurangan sebanyak 0.00830 mm

[6 marks]

[6 markah]

QUESTION 2

SOALAN 2

A parallel composite bar as shown in Figure 2 is integrated by aluminum and bronze bars which has the cross-sectional area of 750mm^2 and 1500mm^2 respectively. The bar is rigidly fixed at both ends. The length of the bars is assumed to be the same. Known that:

Satu bar majmuk selari seperti dalam **Gambarajah 2** adalah terdiri daripada gabungan bahan aluminium dan bahan gangsa dengan luas keratan rentas 750mm^2 dan 1500mm^2 masing-masing. Bar ini dicantumkan secara kaku di kedua-dua hujungnya. Anggapkan panjang kedua-dua bar adalah sama. Diberi bahawa:

$$E_{\text{aluminium}} = 75 \text{ GPa/m}^2 \quad \alpha_{\text{aluminium}} = 22 \times 10^{-6} / ^\circ\text{C}$$

$$E_{\text{bronze}} = 105 \text{ GPa/m}^2 \quad \alpha_{\text{bronze}} = 18 \times 10^{-6} / ^\circ\text{C}$$

CLO1
C3

- (a) Find the stresses set up in the aluminium and bronze if an external compressive load of 45 kN is applied on the composite bar.

Carikan nilai-nilai tegasan yang terbentuk oleh bahan aluminium dan gangsa jika beban mampatan luar sebanyak 45 kN dikenakan ke atas bar majmuk tersebut.

[12 marks]

[12 markah]

CLO1
C3

- (b) Compute the stress developed in the aluminium and bronze once the temperature is raised to 30°C at the same load in (a) is applied.

Kirakan nilai tegasan baharu yang dibentuk oleh bahan aluminium dan gangsa apabila suhu meningkat kepada 30°C pada beban yang sama seperti pada (a) dikenakan ke atas bar majmuk tersebut.

[9 marks]

[9 markah]

CLO1
C3

- (c) Determine the sum of stresses in the aluminium bar and bronze bar due to compressive load in (a) and temperature changes in (b).

Tentukan jumlah tegasan di dalam bar aluminium dan bar tembaga yang disebabkan oleh daya mampatan di (a) dan perubahan suhu di (b).

[4 marks]

[4 markah]

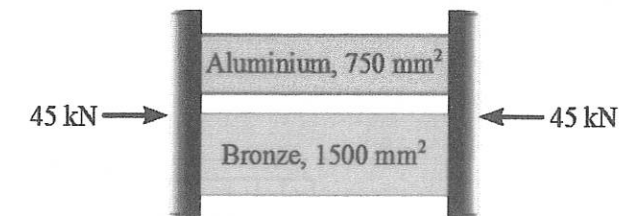

Figure 2 / Rajah 2

QUESTION 3

SOALAN 3

A simply supported beam was subjected the uniformly distributed load and concentrated load as shown in Figure 3.

Rasuk disokong mudah dikenakan daya teragih seragam dan daya tumpu seperti ditunjukkan dalam Rajah 3.

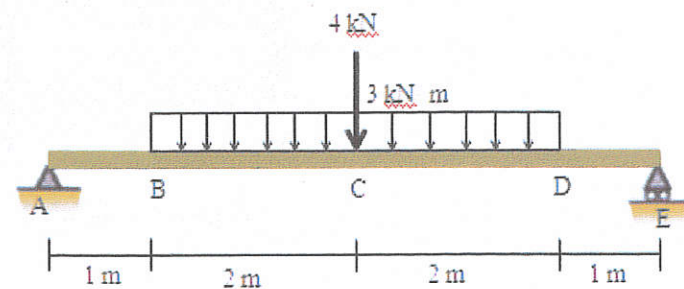

Figure 3/ Rajah 3

CLO1
C2

a) Calculate the reaction force at the support.

Kirakan tindakbalas dipenyokong.

[5 marks]

[5 markah]

CLO2
C5

b) Construct the shear force and bending moment diagram of the beam.

Binakan gambarajah daya ricih dan gambarajah momen lentur.

[16 marks]

[16 markah]

CLO1
C3

c) Identify and specify the magnitude of the maximum bending moment.

Kenalpasti dan nyatakan nilai momen lentur maksimum.

[4 marks]

[4 markah]

QUESTION 4

SOALAN 4

A cross-section of I-beam is shown in Figure 4 (i) below. The beam carries a load as shown in Figure 4 (ii).

Satu rasuk keratan rentas I ditunjukkan dalam Rajah 4 (i). Rasuk tersebut menanggung beban seperti ditunjukkan dalam Rajah 4 (ii).

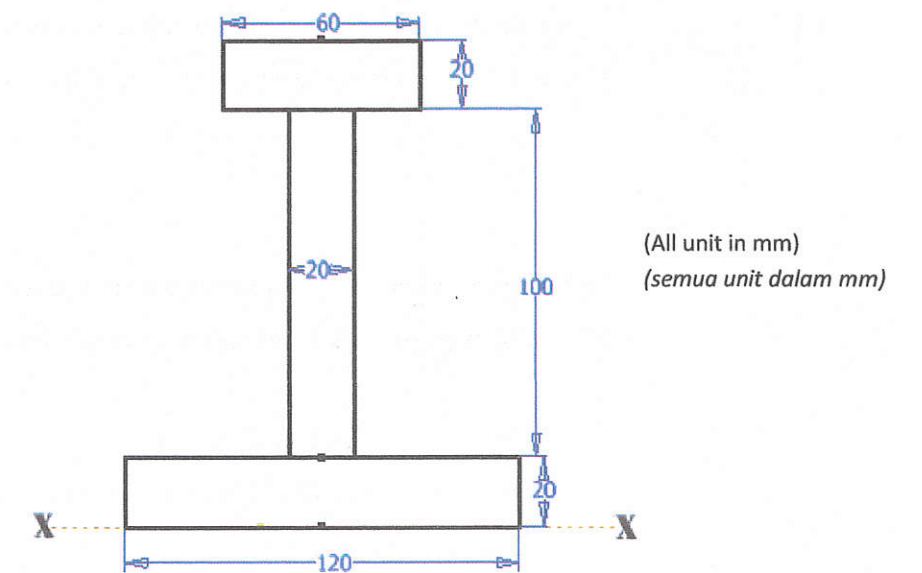

Figure 4(i)

Rajah 4 (i)

(All unit in mm)
(semua unit dalam mm)

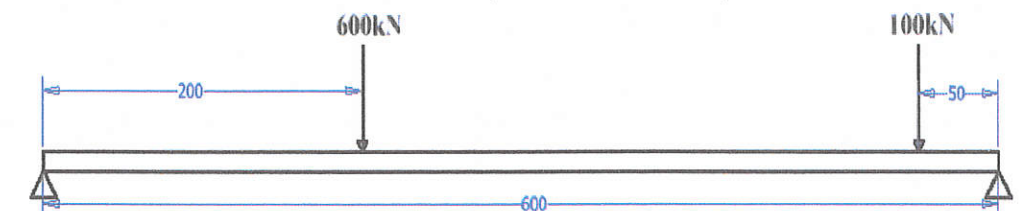

Figure 4(ii)

Rajah 4 (ii)

- CLO1
C2 (a) Determine the position of neutral axis.
Tentukan kedudukan paksi neutral.
- [9 marks]
[9 markah]
- CLO1
C3 (b) Calculate the moment of inertia at the X-X axis.
Kira nilai momen inertia pada paksi X-X.
- [9 marks]
[9 markah]
- CLO1
C3 (c) Calculate the value of maximum bending moment that occurs in the beam.
Kira nilai momen lentur maksimum yang berlaku dalam rasuk.
- [3 marks]
[3 markah]
- CLO1
C3 (d) Calculate maximum bending stress due to compression and tension in the beam.
Kira nilai tegasan lentur maksimum tegangan dan mampatan dalam rasuk.
- [4 marks]
[4 markah]

QUESTION 5

SOALAN 5

CLO1
C3

A simply supported beam shown in **Figure 5** is loaded with uniformly distributed load. Solve the problems below by using the double integration method. Use the modulus of elasticity, $E = 200 \text{ GN/m}^2$

*Rasuk disokong mudah dibebankan beban teragih seragam seperti **Rajah 5**. Selesaikan soalan di bawah dengan menggunakan Kaedah Pengamiran Berganda. Gunakan modulus keanjalan, $E = 200 \text{ GN/m}^2$*

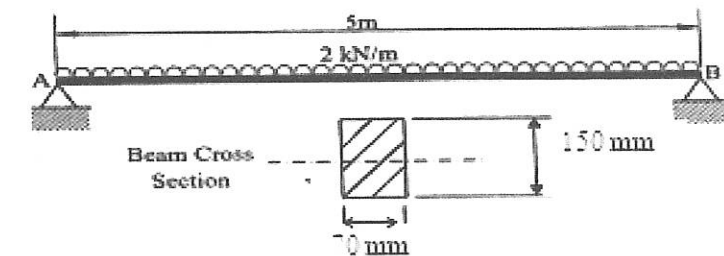

Figure 5/ Rajah 5

CLO1
C3

- a) Derive the equation of elastic curve.
Terbitkan persamaan lengkungan elastic.

[14 marks]

[14 markah]

CLO1
C3

- b) Calculate the maximum slope
Kirakan kecerunan maksimum

[7 marks]

[7 markah]

CLO1
C3

- c) Calculate the deflection at the midpoint of the beam
Kirakan pesongan ditengah-tengah rasuk.

[4 marks]

[4 markah]

QUESTION 6

SOALAN 6

CLO1
C3

- a) A shaft with a diameter of 200 mm and 3 m long transfers 60kW of power while rotating at 450 rpm. Determine the maximum shear stress occurred.

Sebatang aci berdiameter 200 mm dan 3m panjang menghantar kuasa sebanyak 60 k W pada putaran 450 ppm. Tentukan tegasan ricih maksimum yang berlaku pada aci tersebut

[9 marks]

[9 markah]

CLO1
C3

- b) The **Figure 6** below shows a solid circular shaft in serial connection is made from steel with length AB=350 mm and BC=200 mm. The diameter of AB is 60 mm and BC is 30 mm. If a torque 150 Nm is acted on BC, calculate the maximum shear stress in the solid circular shaft and total angle of twist for the shaft. Given $G = 80 \text{ GN/m}^2$.

Rajah 6 di bawah menunjukkan aci bulat padu sambungan sesiri yang diperbuat dari keluli dengan panjang AB = 350 mm dan BC = 200 mm. Diameter bagi AB adalah 60 mm dan BC adalah 30 mm. Jika daya kilasan 150 Nm dikenakan pada bahagian BC, kirakan tegasan ricih maksimum dan sudut puih pada setiap bahagian aci bulat padu tersebut. Diberi $G = 80 \text{ GN/m}^2$.

[16 marks]

[16 markah]

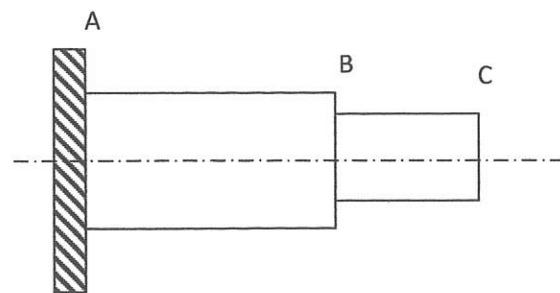

Figure 6/ Rajah 6

SOALAN TAMAT

LIST OF FORMULA JJ310- STRENGTH OF MATERIALSFORCES ON MATERIALS

1. Safety factor = $\frac{\text{Maximum Stress}}{\text{Work Stress}}$
2. Poisson's Ratio, $\nu = \frac{\text{lateral strain}}{\text{longitudinal strain}}$
3. Percent Elongation = $\frac{\text{Elongation}}{\text{Length}} \times 100\%$
4. Percent reduction in area = $\frac{\text{original cross-sectional area} - \text{area at fracture}}{\text{original cross sectional area}} \times 100\%$
5. Strain Energy, $U = \frac{1}{2} P\Delta$.

THERMAL STRESSES AND COMPOSITE BARS

1. Equation of a parallel composite bar subjected to a temperature change.

$$\frac{\sigma_1}{E_1} = \frac{\sigma_2}{E_2} = (\alpha_2 - \alpha_1) \Delta t$$

2. Equation of a series composite bar subjected to a temperature change.

$$\frac{P_1 L_1}{A_1 E_1} + \frac{P_2 L_2}{A_2 E_2} = \Delta t (\alpha_1 L_1 + \alpha_2 L_2)$$

SHEAR FORCES AND BENDING MOMENT

$$\sum M_1 = \sum M_2$$

$$\sum F \uparrow = \sum F \downarrow$$

BENDING STRESS

$$\frac{M}{I} = \frac{\sigma}{y} = \frac{E}{R}$$

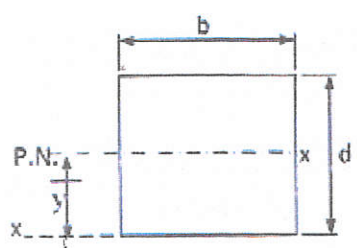
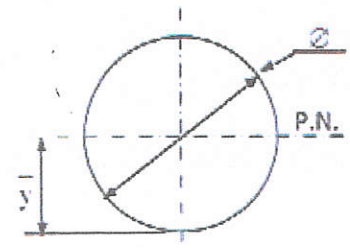
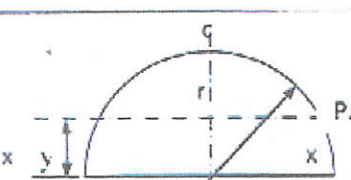
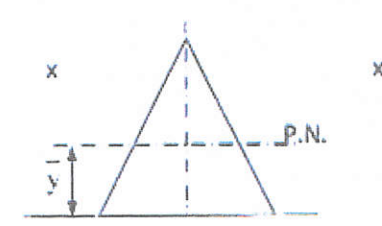
SHAPE	CENTROID	MOMENT OF INERTIA
	$\bar{x} = b/2$ $\bar{y} = d/2$	$I_{xx} = \frac{bd^3}{12}$ $I_{yy} = \frac{bd^3}{3}$
	$\bar{x} = d/2$ $\bar{y} = d/2$	$I_{xx} = \frac{\pi d^4}{64} = \frac{\pi r^4}{4}$
	$\bar{y} = \frac{4r}{3\pi}$	$I_{xx} = 0.11 r^4$ $I_{yy} = \frac{\pi r^4}{8}$
	$\bar{y} = h/3$	$I_{xx} = \frac{bh^3}{36}$ $I_{yy} = \frac{bh^3}{12}$ $I_{zz} = \frac{hb^3}{48}$

TORSION OF SHAFT

1. TORSION FORMULA

$$\frac{T}{J} = \frac{\tau}{R} = \frac{G\theta}{L}$$

2. POLAR MOMENT OF INERTIA

$$J = \frac{\pi d^4}{32}$$

3. SERIES COMPOSITE SHAFT

$$T = \frac{G_1 \theta J_1}{L_1} = \frac{G_2 \theta J_2}{L_2}$$

$$\theta_{AC} = \theta_{AB} + \theta_{BC}$$

$$= \frac{T_1 L_1}{G_1 J_1} + \frac{T_2 L_2}{G_2 J_2}$$

$$= T \left(\frac{L_1}{G_1 J_1} + \frac{L_2}{G_2 J_2} \right)$$

4. PARALLEL COMPOSITE SHAFT

$$T = T_1 + T_2$$

$$\theta = \left(\frac{T_1 L_1}{G_1 J_1} \right) = \left(\frac{T_2 L_2}{G_2 J_2} \right)$$