

**POLITEKNIK SULTAN SALAHUDDIN ABDUL AZIZ SHAH**

**IOT BASED SMART SAFETY SOCKET**

**NAME: MOHAMAD ZAIMIRUL  
HAIKAL BIN ZAMRIZAL**

**REGISTRATION NO:  
08DEP20F2030**

**JABATAN KEJURUTERAAN ELEKTRIK**

**SESI 2 2021/2022**

**POLITEKNIK**

**SULTAN SALAHUDDIN ABDUL AZIZ SHAH**

**IOT BASED SMART SAFETY SOCKET**

**NAME: MOHAMAD ZAIMIRUL      REGISTRATION NO;  
HAIKAL BIN ZAMRIZAL          08DEP20F2030**

This report submitted to the Electrical Engineering Department in fulfillment of the requirement for a Diploma Engineering electronic computer communication.

**JABATAN KEJURUTERAAN ELEKTRIK**

**SESI 2 2021/2022**

## **CONFIRMATION OF THE PROJECT**

The project report titled "IOT based smart safety socket " has been submitted,  
reviewed and verified as a fulfills the conditions and requirements of the Project

Writing as stipulated

Checked by:

Supervisor's name: NUR SURIYA BINTI MOHAMAD

Supervisor's signature:

Date :

Verified by:

Project Coordinator name :

Signature of Coordinator :

Date :

“I acknowledge this work is my own work except the excerpts I have already explained to our source”

1. Signature

: 

Name : **MOHAMAD ZAIMIRUL HAIKAL BIN ZAAMRIZAL**

Registration Number : **08DEP20F2030**

Date :

**DECLARATION OF ORIGINALITY AND OWNERSHIP**

**TITLE : IOT BASED SMART SAFETY SOCKET**

**SESSION: DECEMBER 2017**

**1. I, 1. MOHAMAD ZAIMIRUL HAIKAL BIN ZAMRIZAL020612-10-0693**

is a final year student of **Diploma in Engineering Electronics Computer Communication, Department of Electrical, Politeknik Sultan Salahuddin Abdul Aziz Shah**, which is located at **Persiaran Usahawan,40140 Shah Alam Selangor Darul Ehsan**. (Hereinafter referred to as 'the Polytechnic').

- 2. I acknowledge that 'The Project above' and the intellectual property therein is the result of our original creation /creations without taking or impersonating any intellectual property from the other parties.
- 3. I agree to release the 'Project' intellectual property to 'The Polytechnics' to meet the requirements for awarding the **Diploma in Engineering Electronics Computer Communication** to me.

Made and in truth that is recognized by;

a) **MOHAMAD ZAIMIRUL HAIKAL BIN ZAMRIZAL**  
(Identification card No: - 020612-10-0693)



.....  
) **MOHAMAD ZAIMIRUL HAIKAL BIN ZAMRIZAL**

In front of me, **NUR SURIYA BINTI MOHAMAD** (Click here to enter text.)  
As a project supervisor, on the date:

) .....  
) **NUR SURIYA BIN MOHAMAD**

## **ACKNOWLEDGEMENTS**

I have taken efforts in this Project. However, it would not have been possible without the kind support and help of many individuals and organizations. I would like to extend my sincere thanks to all of them. I am highly indebted to Mrs. Nur Suriya Binti Mohamad for their guidance and constant supervision as well as for providing necessary information regarding the Project & also for their support in completing the Project.

I would like to express my gratitude towards my parents & member for their kind co-operation and encouragement which help me in completion of this Project. I would like to express my special gratitude and thanks to industry persons for giving me such attention and time.

My thanks and appreciations also go to my colleague in developing the Project and people who have willingly helped me out with their abilities.

## **ABSTRACT**

The Internet of Things (IoT) describes the network of physical objects things that are embedded with sensors, software, and other technologies for the purpose of connecting and exchanging data with other devices and systems over the internet. These devices range from ordinary household objects to sophisticated industrial tools. With more than 7 billion connected IoT devices today, experts are expecting this number to grow to 10 billion by 2020 and 22 billion by 2025. IoT ecosystem consists of web-enabled smart devices that use embedded systems, such as processors, sensors, and communication hardware, to collect, send and act on data they acquire from their environments. IOT device share the sensor data they collect by connecting to an IoT gateway or other edge device where data is either sent to the cloud to be analyzed or analyzed locally. The internet of things helps people live and work smarter, as well as gain complete control over their lives. In addition to offering smart devices to automate homes. Electric current refers to the flow of electricity in an electronic circuit, and to the amount of electricity flowing through a circuit. It is measured in amperes (A). The larger the value in amperes, the more electricity is flowing in the circuit. Energy current is a somewhat informal term that is used, on occasion, to describe the process of energy transfer in situations where the transfer can usefully be viewed in terms of a flow. It is particularly used when the transfer of energy is more significant to the discussion than the process by which the energy is transferred. For instance, the flow of fuel oil in a pipeline could be considered as an energy current, although this would not be a convenient way of visualising the fullness of the storage tanks.

## ABSTRAK

Internet of Things (IoT) menerangkan rangkaian objek fizikal yang dibenamkan dengan penderia, perisian dan teknologi lain untuk tujuan menyambung dan bertukar data dengan peranti dan sistem lain melalui Internet. Peranti ini terdiri daripada objek rumah biasa kepada alat industri yang canggih. Dengan lebih 7 bilion peranti IoT yang disambungkan hari ini, pakar menjangkakan jumlah ini meningkat kepada 10 bilion menjelang 2020 dan 22 bilion menjelang 2025. Ekosistem IoT terdiri daripada peranti pintar didayakan web yang menggunakan sistem terbenam, seperti pemproses, penderia dan komunikasi perkakasan, untuk mengumpul, menghantar dan bertindak ke atas data yang mereka peroleh daripada persekitaran mereka. Peranti IOT berkongsi data penderia yang mereka kumpulkan dengan menyambung ke get laluan IoT atau peranti tepi lain yang mana data dihantar sama ada ke awan untuk dianalisis atau dianalisis secara setempat. Internet of things membantu orang ramai hidup dan bekerja dengan lebih bijak, serta memperoleh kawalan sepenuhnya ke atas kehidupan mereka. Selain menawarkan peranti pintar untuk mengautomasikan rumah. Arus elektrik merujuk kepada aliran elektrik dalam litar elektronik, dan kepada jumlah elektrik yang mengalir melalui litar. Ia diukur dalam ampere (A). Lebih besar nilai dalam ampere, lebih banyak elektrik mengalir dalam litar. Arus tenaga ialah istilah yang agak tidak formal yang digunakan, kadangkala, untuk menerangkan proses pemindahan tenaga dalam situasi di mana pemindahan boleh



dilihat secara berguna dari segi aliran. Ia digunakan terutamanya apabila pemindahan tenaga adalah lebih penting kepada perbincangan daripada proses pemindahan tenaga. Sebagai contoh, aliran minyak bahan api dalam saluran paip boleh dianggap sebagai arus tenaga, walaupun ini bukan cara yang mudah untuk menggambarkan kepenuhan tangki simpanan.

## TABLE OF CONTENTS

<b>CONFIRMATION OF THE PROJECT</b>	<b>i</b>
<b>DECLARATION OF ORIGINALITY AND OWNERSHIP</b>	<b>iii</b>
<b>ACKNOWLEDGEMENTS</b>	<b>iv</b>
<b>ABSTRACT</b>	<b>v</b>
<b>TABLE OF CONTENTS</b>	<b>viii</b>
<b>CHAPTER 1</b>	<b>1</b>
<b>1 INTRODUCTION</b>	<b>1</b>
1.1 Introduction	1
1.2 Background Research	1
1.3 Problem Statement	2
1.4 Research Objectives	2
1.5 Scope of Research	2
1.6 Project Significance	3
1.7 Chapter Summary	3
<b>CHAPTER 2</b>	<b>4</b>
<b>2 LITERATURE REVIEW</b>	<b>4</b>
2.1 Introduction	4
2.2 Motor Skill Challenges in Autistic Children (Literature Review Topic 1)	
2.2.1 Previous Research (Subtopic Literature Review Topic 1)	5
2.3.2 liquid crystal display	
	<b>Er ro r! Bo ok m ar k no t de fin ed .</b>
2.3.3 Arduino	11
2.4 Chapter Summary	11
<b>CHAPTER 3</b>	<b>12</b>
<b>3 RESEARCH METHODOLOGY</b>	<b>12</b>
3.1 Introduction	12
3.2 Project Design and Overview.	12
3.2.1 Block Diagram of the Project	12
3.2.2 Flowchart of the Project 2	13
	viii

3.2.3	Project Description	14
3.3	Project Hardware	15
3.3.1	Schematic Circuit	15
3.3.2	Description of Main Component	16
3.3.2.2	current sensor	17
<b>3.3.2.3</b>	<b>LCD</b>	<b>Er</b>
	<b>ror! Bookmark not defined.</b>	
3.3.3	Circuit Operation	18
3.4	Project Software	19
3.5	Prototype Development	20
3.7	Chapter Summary	20
<b>CHAPTER 4</b>		<b>20</b>
<b>4</b>	<b>RESULTS AND DISCUSSION</b>	<b>21</b>
4.1	Introduction	21
4.2	Results and Analysis	21
4.3	Discussion	22
4.4	Chapter Summary	23
<b>CHAPTER 5</b>		<b>24</b>
<b>5</b>	<b>CONCLUSION AND RECOMMENDATIONS</b>	<b>24</b>
5.1	Introduction	24
5.2	Conclusion	25
5.3	Suggestion for Future Work	26
5.4	Chapter Summary	27
<b>CHAPTER 6</b>		<b>27</b>
<b>6</b>	<b>PROJECT MANAGEMENT AND COSTING</b>	<b>27</b>
6.1	Introduction	28
6.2	Gant Chart and Activities of the Project	28
6.3	Milestone	29
6.4	Cost and Budgeting	29
6.5	Chapter Summary	30
<b>REFERENCES</b>		<b>31</b>
<b>7</b>	<b>APPENDICES</b>	<b>32</b>
	APPENDIX A- PROGRAMMING	32
	APPENDIX B- PROJECT MANUAL/PRODUCT CATALOGUE	40

# CHAPTER 1

## 1 INTRODUCTION

### 1.1 Introduction

This project means to set the voltage or electric current that flows until it stops at a set point. For example, we set the value of the electric current to be 2.1A and the electric current will flow up to that point. The purpose of this project is to avoid fire and short circuit. The system uses current sensor and Arduino nodeMCU. The Internet of Things (IoT) describes the network of physical objects“things” that are embedded with sensors, software, and other technologies for the purpose of connecting and exchanging data with other devices and systems over the internet. then, this project is very suitable to be at home or at work to use current perfectly. In this project, the results will also be shown on an LCD[1]. Electrical energy as the energy generated by the movement of electrons from one point to another. Three-conductor wire has two hots black and red and a white neutral. Though normally used for three-way switching, three-conductor wire is commonly used for duplex receptacle wiring as well.[2]

### 1.2 Background Research

Current voltage is the difference in electric potential between two points. Current is just the rate of flow of electric charge. Next, A Volt is the potential difference which moves one joule of energy per coulomb charge between two points. One volt is the difference of electric positional equal to one ampere of current dissipates one watt of power between two conducting points. Energy current is a flow of energy defined by the Poynting vector, as opposed to normal current. It was originally postulated by Oliver Heaviside. It is also an informal name for Energy flux. At its most basic, current = flow. An ampere (AM-pir), or amp, is the international unit used for measuring current. In 2021, the average annual electricity consumption for a U.S. residential

utility customer was 10,632 kilowatthours (kWh), an average of about 886 kWh per month.

### **1.3 Problem Statement**

This project has problems, especially at home or in the office, it is very dangerous if you are not careful. The electric fire will exceed the limit set and can involve a short circuit because we don't even know how much voltage goes into the socket. Next, it can cause fire. This fire has many categories including short circuit and forgetting to turn off the plug switch when charging the phone is also one of the fires. Then, it can also cause a fire due to old house wires and that is another cause that can cause a short circuit. Wires are divided into three, namely earth, neutral and life wires. A person's carelessness can cause many unexpected accidents, so just be careful and remember to remember each other.

### **1.4 Research Objectives**

The main objective of this Project is the main goal of this project to save energy electricity and avoid fire. More specifically the principal objective of this research are:

- To design a safety socket system with a current sensor
- to detect an overloading current. 2. To alert user through a mobile application.

### **1.4 Scope of Research**

Project will be completed within 14 weeks, cost of developing project is RM250.00, hardware resources are available for two months. Average Home Energy Consumption. According to data from 2020, the average amount of electricity an American home uses is **10,715 kilowatt-hours** (kWh). If you divide this number by 12 (months in a year), the average residential utilities customer uses 893 kWh per month. project is suitable for home and office because it can make our daily life easier. The size of your home will have an impact on your average home power usage. For example, larger homes tend to consume more energy than smaller homes because it takes more energy to heat and cool a bigger space.

## **1.5 Project Significance**

The applicability of this project can help with problems at home, and it can also help in the office. Therefore, how this project can prevent short circuits from happening and fires due to excessive electric current.

## **1.6 Chapter Summary**

In this chapter, I have given an overview of the upcoming and detailed project background of the original concept for the start of this project as well as an ongoing challenge, such as forgetting to turn off the plug switch in addition, I presented the project objectives. The main goal this project is to help simplify our daily work in saving time, money, and manpower, and I also remember that project importance based on the objective of the study. I hope this project will be useful many people.

## CHAPTER 2

### 2 LITERATURE REVIEW

#### 2.1 Introduction

A literature review serves as the foundation for high-quality medical education research, assisting in the maximization of relevance, originality, generalizability, and impact. A literature review provides context, informs methodology, maximizes innovation, minimizes duplicative research, and guarantees compliance with professional norms. Iterative literature reviews take time and should be conducted throughout the study process. Researchers should make the best use of available resources, such as human resources, search tools, and current literature,

Originally this project was specially built for homes or offices, so if a short circuit occurs in a house due to excessive current voltage. Therefore, I found that there is a lot of carelessness on the part of teenagers because they forget to turn off the switch plug when charging the phone. Then, this project can help lighten our burden. Therefore, I decided to create a project based on a IOT smart safety socket that can make it easier for people in the youth as well as families. This project also does not require such expensive costs and it is easy to charge phones or the like. In office there are workers who are very busy due to a lot of work, maybe here we can conclude that they are very careless to turn off the switch plug while working. Both the youth and the workers can be used as best as possible.

##### 2.1.0 Fault detection challenges in voltage current

An electrical fault detector system detects electrical faults in an electrical distribution system by monitoring one or more conductors and producing an input signal

representing one or more electrical signal conditions in the circuit to be monitored. The factors that should be considered in developing a PMFD strategy are ease in development, diagnostic ability, fault detection speed, robustness to noise, generalization capability, and handling of nonlinearity. Fault detection is the process of discovering the presence of a fault in any equipment before it manifests itself in the form of a breakdown. It is the most important stage of FDD as all the downstream processes depend on its accuracy.

### 2.1.1 Previous Research

NO	TITLE/AUTHOR	OBJECTIVE	METHOD	RESULT
1.	<ul style="list-style-type: none"> <li>➤ MorSocket: An Expandable IoT-Based Smart Socket System</li> <li>➤ Yi-Bing Lin, Chun-Ming Huang ,Li-Kuan Chen, Gang-Neng Sung , Chih-Chyau Yang.</li> <li>➤ 2018</li> </ul>	<ul style="list-style-type: none"> <li>• MorSocket can be controlled by smartphones through either Wi-Fi or Bluetooth.</li> <li>• MorSocket allows control of multiple sockets (in the current implementation, the maximum number is 30) with only one wireless module that supports both Wi-Fi and Bluetooth.</li> <li>• Through the light sensor, MorSocket is automatically turned on or off according to the light</li> </ul>	<ol style="list-style-type: none"> <li>1. A dropdown menu for the user to select a MorSocket device through its MAC address (or an alias). In our example, the selected MAC address is F728DC9DD4 FA.</li> <li>2. A button for the user to disable/enable a slave socket in the MorSocket device</li> <li>3. A label shows the index of the slave socket</li> <li>4. A switch button icon for the user to</li> </ol>	<ul style="list-style-type: none"> <li>• smart socket system called MorSocket that allows the user to arbitrarily expand the sockets in the system, and control multiple sockets within a control webpage. These sockets share the same wireless communication module and therefore the hardware cost of MorSocket is lower than the single-socket solutions. By integrating MorSensor with an IoT management platform called IoTtalk, MorSocket is automatically controlled by arbitrary</li> </ul>



		intensity of the room.	turn on/off the socket	sensors for temperature, humidity, UV, CO2 and so on
			5. A dropdown list for the user to specify the socket alias. Several popular home appliances are listed for selection. The user can also add new names to the list. This dropdown list provides the mapping between the sockets and the connected home appliances, so that the user will not accidentally presses the wrong buttons.	
2	<ul style="list-style-type: none"> <li>➤ Residence Energy Control System Based on Wireless Smart Socket and IoT</li> <li>➤ Kun-Lin Tsai, Fang-Yie Leu, IIsun You</li> <li>➤ 2016</li> </ul>	<ul style="list-style-type: none"> <li>• The main goal is raising consumers' energy consumption awareness, potentially inspiring them to be more energy efficient.</li> <li>• To automatically control those</li> </ul>	<ul style="list-style-type: none"> <li>• many energy control methods have been proposed.</li> <li>• IoT is a network system consisting of electronic devices, software, sensors and networks.</li> </ul>	<ul style="list-style-type: none"> <li>• One of the main purposes of constructing a smart house is to automatically control those appliances in the house to achieve the goals of energy saving and smart</li> </ul>

		<p>appliances in the house to achieve the goals of energy saving and smart living.</p>		<p>living. In this paper, the RECoS controls the energy consumption in a residence through IoT and smart sockets. The RECoS provides four control modes to control the on/off state of home appliances connected to smart sockets</p>
3	<ul style="list-style-type: none"> <li>➤ Smart Socket for Electricity Control in Home Environment</li> <li>➤ Lukius Natanael Phangberthaa, Anindya Fitria, Intan Purnamasaria, Yohan Mulionob,</li> <li>➤ 2019</li> </ul>	<ul style="list-style-type: none"> <li>• communication through middleware and sensors, creates many possibilities of variety creative applications<sup>2</sup>. Where leading to technology of computing to be exist everywhere and anywhere, which the device be able to communicate between itself through wireless technology and internet<sup>3</sup>.</li> </ul>	<ul style="list-style-type: none"> <li>• The smart socket server functions as a provider for smart socket device and smart socket application. The server provides services in the form of a web service that uses the PHP programming language.</li> </ul>	<p>Terminal of full control of each socket were designed and made, using an android-based mobile application as its controller. Simple commands and features have been implemented such as turning on and off, electricity monitoring per socket, timer, renaming each socket as user preferred. The tool has been tested for its endurance with high voltage. Electricity saving has been proven with a daily yet often forgotten, lamp. Cost and importantly, energy efficiency could have been implemented better if a simplicity of controlling it has been reached.</p>

4	<ul style="list-style-type: none"> <li>➤ Sensor technology for smart home</li> <li>➤ DanDing<sup>ab</sup> Rory A.Cooper<sup>ab</sup> Paul F.Pasquina<sup>c</sup> LaviniaFici-Pasquina<sup>d</sup></li> </ul>	<ul style="list-style-type: none"> <li>• A smart home refers to a residence augmented with sensors to observe the environment and devices/actuators to provide proactive services with the goal to improve the occupant's experience.</li> </ul>	<ul style="list-style-type: none"> <li>• Three types of sensor technologies have demonstrated ability to address the challenges of sensing human activity in a smart home, including wearable devices where sensors are worn by the residents, direct environment components where sensors are distributed in the environment, and infrastructure mediated systems where sensors are installed on an existing home infrastructure.</li> </ul>	<ul style="list-style-type: none"> <li>• In spite of the growing number of initiatives in smart home area, challenges still exist in clinical, technical, and ethical aspects of sensor technology for smart homes.</li> </ul>
5	<ul style="list-style-type: none"> <li>➤ Smart plugs perceived usefulness and satisfaction.</li> <li>➤ MohammedG hazal<sup>a</sup>MuhammadAkmal<sup>a</sup>Shilpalyanna<sup>b</sup>KilaniGhoudi<sup>c</sup></li> </ul>	<ul style="list-style-type: none"> <li>• system consists of multiple smart plugs connected in a <u>wireless sensor network</u></li> </ul>	<ul style="list-style-type: none"> <li>• The smart plugs use the <u>ZigBee protocol</u> in a mesh network to extend their range and communicate</li> </ul>	<ul style="list-style-type: none"> <li>• Slave plugs for higher ratings can be designed by changing the choice of electronics. The overall cost of making the</li> </ul>

		<ul style="list-style-type: none"> <li>The network consists of two unit types:(1)a slave unit type with power measuring and control electronics (the smart plug itself); and (2) a master unit type that coordinates the network activities and provides access to its collected data.</li> </ul>	<p>with a master unit.</p> <ul style="list-style-type: none"> <li>The master unit uses the home's existing Wifi network to serve the user information and control capabilities.</li> </ul>	<p>master and slave unit is 180 dirhams and 400 dirhams for the master unit. The costs are based on prototype costs and while low can be significantly reduced at production time.</p>
--	--	---	--	--

## 2.2 Control System

NodeMCU is a low-cost open source IoT platform. It initially included firmware which runs on the ESP8266 Wi-Fi SoC from Espressif Systems, and hardware which was based on the ESP-12 module. Later, support for the ESP32 32-bit MCU was added. NodeMCU is an open-source platform based on ESP8266 which can connect objects and let data transfer using the Wi-Fi protocol. NODEMCU is a development board with ESP8266 and a firmware with the same name. Similarly the Arduino Uno is a microcontroller board based on 8 bit ATmega328P microcontroller. NodeMCU is an open source development board and firmware based in the widely used ESP8266 12E Wi-Fi module. It allows you to program the ESP8266 Wi-Fi module with the simple and powerful LUA programming language or Arduino IDE

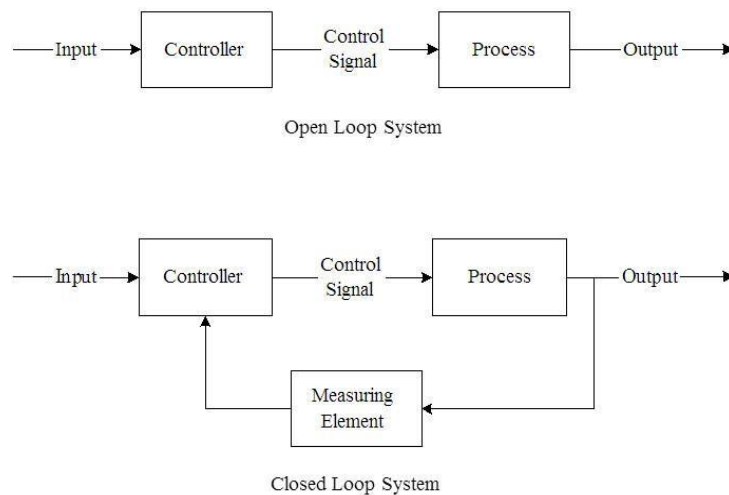

Figure 2.1: Block diagram of open loop and closed loop system

### 2.2.0 Current sensor

A current sensor is a device that detects and converts current to an easily measurable output voltage, which is proportional to the current through the measured path. Current is the rate at which electrons flow past a point in a complete electrical circuit.[3]

### **2.2.1 Liquid crystal display (LCD)**

A liquid-crystal display is a flat-panel display or other electronically modulated optical device that uses the light-modulating properties of liquid crystals combined with polarizers. Liquid crystals do not emit light directly but instead use a backlight or reflector to produce images in color or monochrome.[4]

### **2.2.2 Arduino**

Arduino consists of both a physical programmable circuit board often referred to as a microcontroller and a piece of software. Next, this project uses Arduino nodeMCU, well NodeMCU is a low-cost open source IoT platform. It initially included firmware which runs on the ESP8266 Wi-Fi SoC from Espressif Systems, and hardware which was based on the ESP-12 module. Later, support for the ESP32 32-bit MCU was added.

### **2.2.3 Chapter Summary**

In this chapter ,have told how the smart safety socket project happened and also research related to the project. Therefore, there are methods, sensors, and results for each project that they have prepared. then, the most important control system is Arduino nodeMCU

## CHAPTER 3

### 3 RESEARCH METHODOLOGY

#### 3.1 Introduction

The practical "how" of any given piece of research is simply referred to as research methodology. It is primarily about how a researcher designs a study in a systematic manner to produce accurate and trustworthy results that address the research aims and objectives. A very complete approach is being undertaken to actualize this project as a ready-to-use product with safety characteristics. A step-by-step method is followed to ensure that the Project is completed on schedule. This includes the system current sensor to calculate how much voltage comes out to be set through the phone. Therefore, the LCD and buzzer will light up immediately if the current voltage that comes out is excessive according to what is set.

#### 3.2 Project Design and Overview.

As discussed in the previous chapter, Arduino as the main controller. The Arduino controller circuit is designed using Proteus software and then converted to a PCB circuit. The current sensor result will be connected to the phone to set how much current voltage comes out through the LCD.

##### 3.2.0 Block Diagram of the Project

This block diagram shows how the smart safety socket works. Therefore, the input is the current sensor, and the process will go through the Arduino node MCU. Next,

the output will come out through the phone, LCD, led (green, yellow, and red) and buzzer.

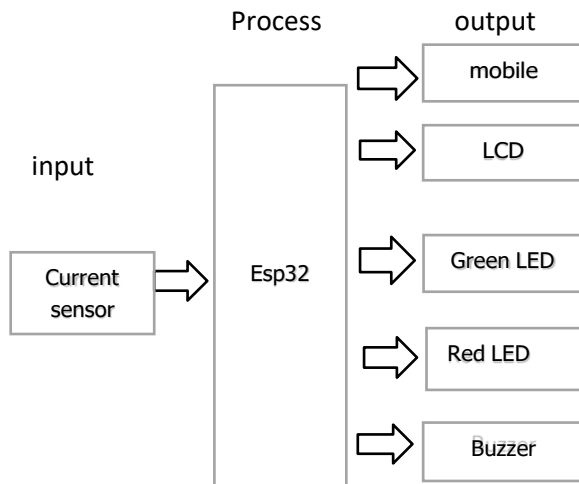

Figure 3.2.0: Block diagram of IOT smart safety socket

### 3.2.1 Flowchart of the Project 2

shows the circuit diagram of the whole system. It is show how to IOT based safety socket work.



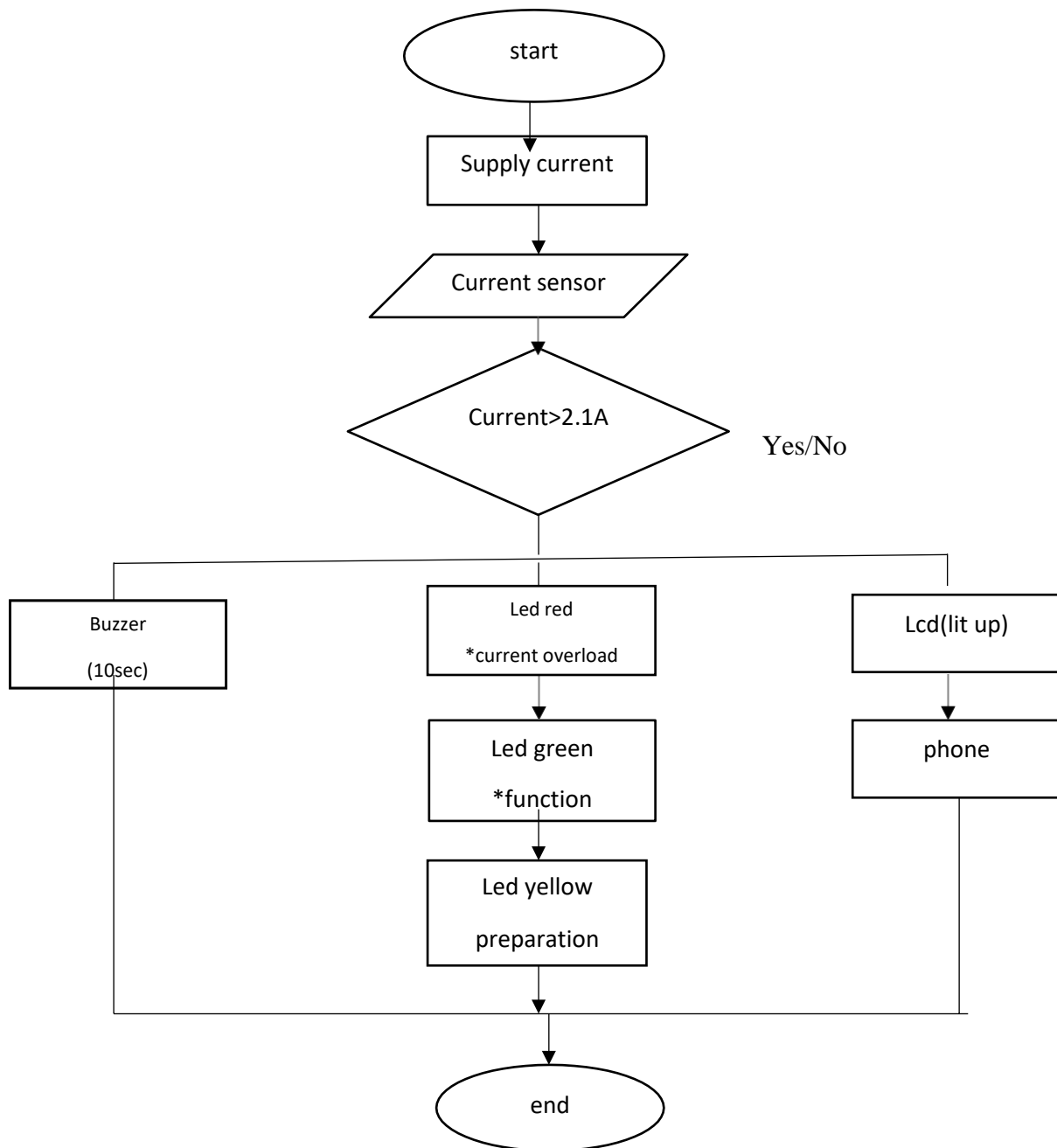

Figure 3.1: Flow chart of operation of the system

### 3.2.2 Project Description

As mentioned in section 3.2.0 and 3.2.2, this project tells how the smart socket works, so first there must be a supply current connected to the current sensor that has been set to 2.1A only. Next, it will be connected to 3 LEDs which are red (the circuit

is not working) while the green led (the circuit is working perfectly) so this means that if the voltage current that comes out will light up red and if it lights up green, it means that the set voltage current is correct. Then it will connect to the buzzer, this component will sound if the current voltage is excessive. Next, for knowledge to set the current sensor, it is connected to the phone and output to the LCD.

### **3.3 Project Hardware**

The main controller, as mentioned in the previous chapter, is Arduino.. The receiving voltage current end will be detected by the current Sensor. The received voltage current is then connected to a current sensor. The Arduino processes the data from the sensor, and the data is then sent via Wi-Fi and the phone. it is a phone that can connect Wi-Fi for data and output on the lcd

#### **3.3.0 Schematic Circuit**

This circuit shows that the smart safety socket works by using AutoCAD.

Figure 3.2 shows the overall circuit diagram of this Project.

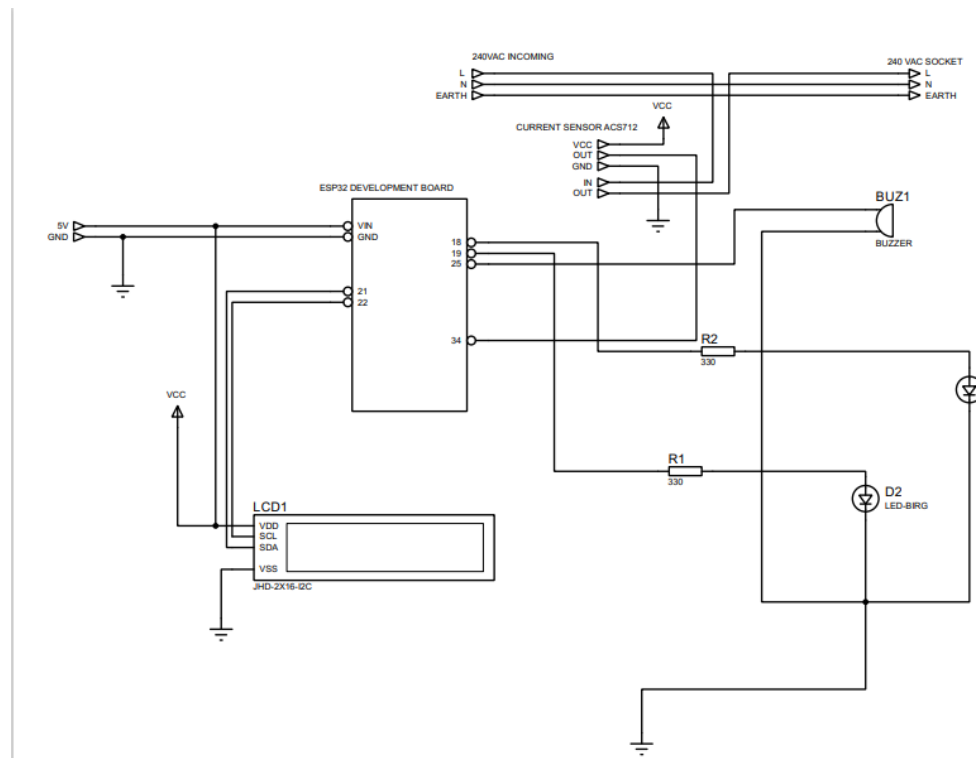

Figure 3.2: Circuit Diagram

\*Images may be subject to copyright

### 3.3.1 Description of Main Component

The main component in this project is the Arduino node MCU as a project. heart, current This sensor functions to measure the current voltage from the current supplier and LCD to display the data obtained during the test.

#### 3.3.1.1 ESP32



ESP32 is a series of low-cost, low-power systems on a chip microcontroller with integrated Wi-Fi and dual-mode Bluetooth[5]. The ESP32 series employs either a Tensilica Xtensa LX6 microprocessor in both dual-core and single-core variations, Xtensa LX7 dual-core microprocessor or a single-core RISC-V microprocessor and includes built-in antenna switches, RF balun, power amplifier, low-noise receive amplifier, filters, and power-management modules. ESP32 can perform as a complete standalone system or as a slave device to a host MCU, reducing communication stack overhead on the main application processor. ESP32 can interface with other systems to provide Wi-Fi and Bluetooth functionality through its SPI / SDIO or I2C / UART interfaces [6].

### 3.3.1.2 Current sensor



A current sensor is a device that detects and converts current to an easily measurable output voltage, which is proportional to the current through the measured path. There are a wide variety of sensors, and each sensor is suitable for a specific current range and environmental condition. Next, current sensors are either open- or closed-loop. Open-loop current sensors measure AC and DC currents and provide electrical isolation between the circuit being measured and the output of the sensor (the primary current is measured without electrical contact with the primary circuit, providing galvanic isolation). Then, The most common way to measure current in a circuit is to break the circuit open and insert an “ammeter” in series (in-line) with the circuit so that all electrons flowing through the circuit also have to go through the meter.

### 3.3.1.3 LCD

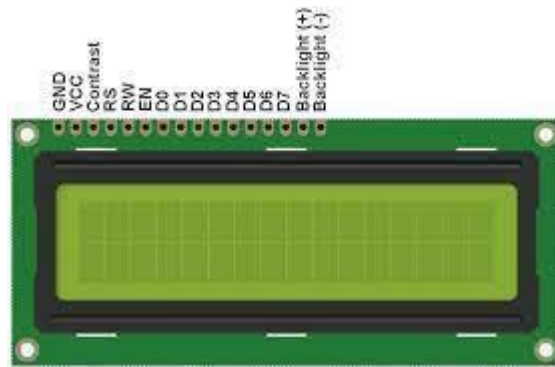

A liquid-crystal display (LCD) is a flat-panel display or other electronically controlled optical device that uses liquid crystals' light-modulating characteristics in conjunction with polarizers. Liquid crystals do not emit light directly, but rather need a backlight or reflector to generate color or monochrome images. LCDs can display arbitrary or fixed images with low information content that can be displayed or hidden. Preset words, numerals, and seven-segment displays, such as those seen in digital clocks, are all examples of devices having these displays. They both use the same basic technology, with the exception that arbitrary images are created using a matrix of small pixels, whilst other displays use larger elements.

### 3.3.2 Circuit Operation

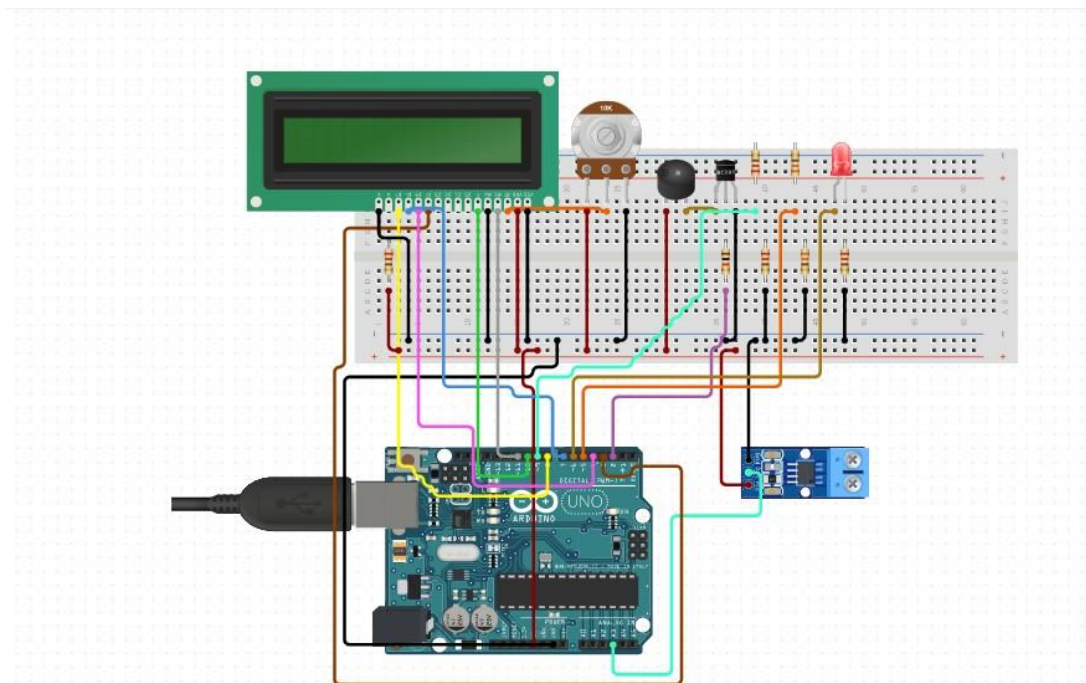

### 3.4 Project Software

The software that has been used in this project is Blynk and Arduino IDE. This software is used to give instruction or to control the circuit and to get the reading while to display the output.



#### 3.4.0 Description of simulation

The simulation result using the circuit design employing Arduino Uno, LCD, current sensor, and led is shown in Diagram 3.3.2. when the system on LCD will light up according to the set voltage current such as (2.1A), and the green led will light up and if the voltage current is excessive the buzzer will sound along with the red led.

### 3.5 Prototype Development

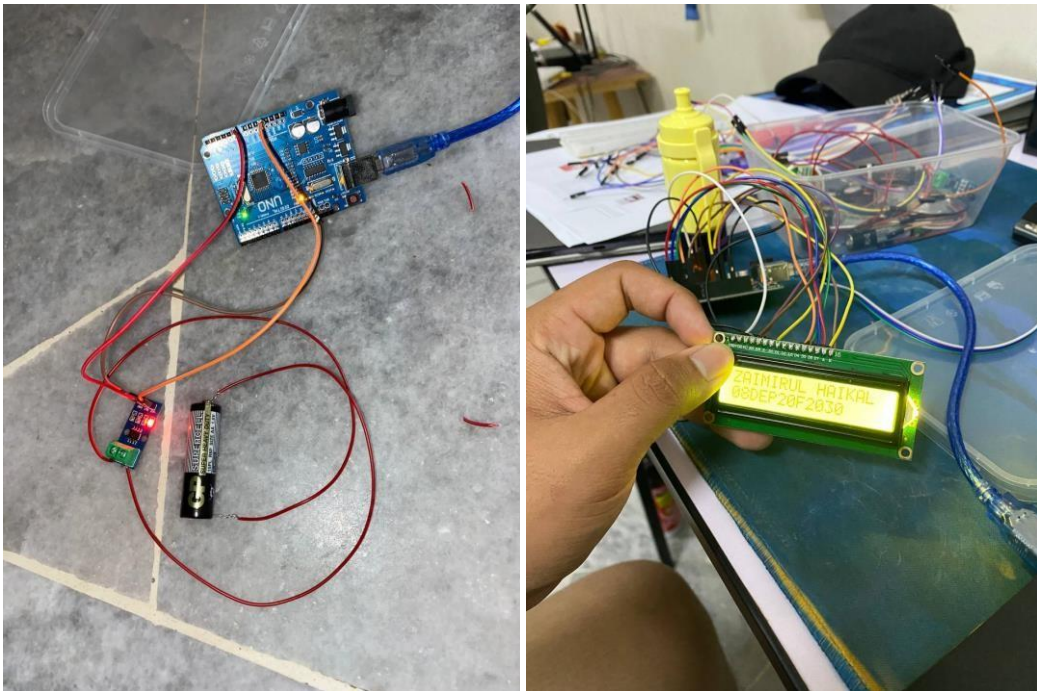

Connect current sensor

Connect LCD (successful)

Figure 3.5

### 3.6 Chapter Summary

This chapter details the design and overview of the project, including a flowchart for the project and project block diagram. Other than that, this chapter discuss the components used in this project. The system will have a transmitter and We will integrate all components from the previous circuit into one circuit. The heart of this project will be ESP 32.

## CHAPTER 4

## 4 RESULTS AND DISCUSSION

### 4.1 Introduction

In this chapter, the matters about the technical information of the project and the results will be discussed. As an illustration, I set a limit of 3.8A, so if the current surpasses that, a notification will be issued, and a buzzer will sound. A current sensor is a device that detects and converts current to an easily measurable output voltage, which is proportional to the current through the measured path. There are a wide variety of sensors, and each sensor is suitable for a specific current range and environmental condition. ESP32 is a low-cost, low-power Microcontroller with integrated Wi-Fi and Bluetooth. It is the successor to the ESP8266 which is also a low-cost Wi-Fi microchip albeit with limited vastly limited functionality. Blynk is an IoT platform for iOS or Android smartphones that is used to control Arduino, Raspberry Pi, and NodeMCU via the Internet. This application is used to create a graphical interface or human machine interface (HMI) by compiling and providing the appropriate address on the available widgets.

### 4.2 Results and Analysis



1. Socket active when you on switch



2. example aps blynk



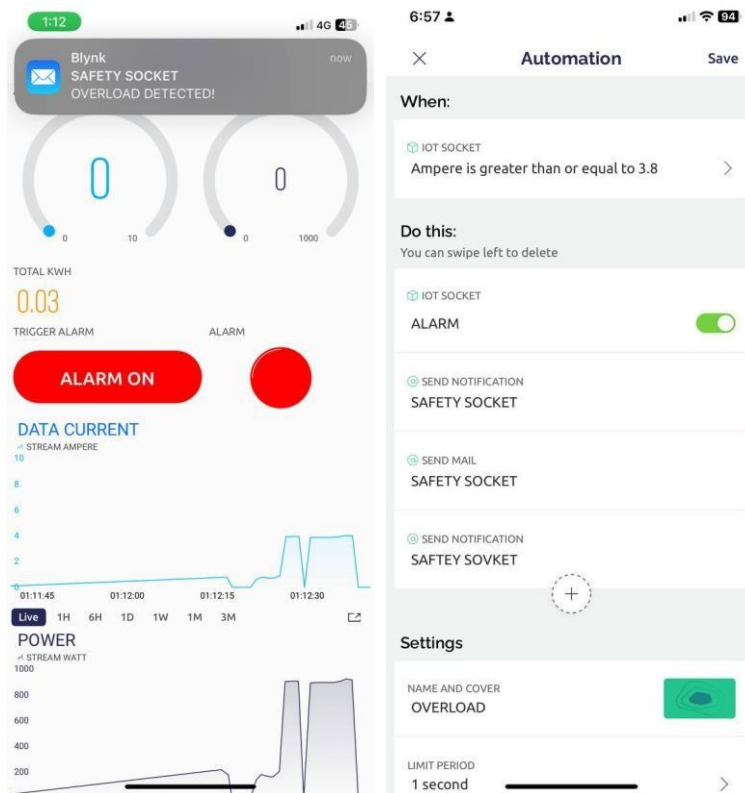

3. When current overload then 4. you can set current (A) at this app blynk  
 Notifications will come out.

Figure 4.2 result

### 4.3 Discussion

In recent years, the Internet of Things (IoT) has revolutionized various aspects of our lives, including the way we interact with everyday objects. One such area of application is the realm of home automation. This project aims to explore the concept of an IoT-based smart socket, which enhances power management and control capabilities within a smart home environment. By integrating IoT technologies with traditional electrical sockets, this project aims to provide users with advanced functionalities, convenience, and improved energy efficiency. In this project, we can find out that if someone uses a plug switch but forgets to turn it off, a notification will be sent, and a buzzer sound will be made. Since older homes typically do not provide stable current, this project is ideal for usage in such homes or in older homes found in rural areas.

According to the Energy Information Administration (EIA), the average American home uses an average of 10,632 kilowatt-hours (kWh) of electricity per year. That's 29,130 watts (W) per day, which can be divided by 24 hours to get an average of 1,214 W to power a home throughout the day. Next, Energy Monitoring and Analytics: The smart socket will monitor energy consumption of connected devices and provide real-time data on energy usage. It will also offer insights and analytics to help users identify power-hungry devices and optimize energy consumption.

#### **4.4 Chapter Summary**

This Tutorial/Project will show the simplest First IOT project with ESP 32, how to light a Physical-LED connected to any ESP 32 Digital pin by using the button/button in the Blynk App and the simplest sketch. LED is the simplest example to see the communication on the App Blynk works fine. After successfully turning on the plug socket can be seen on the LCD output kw and Ampere by changing the coding. Using the Blynk App with the ESP 32 is very easy, but the ESP 32 needs to be connected to a Wi-Fi source that has a phone hotspot Internet.

## CHAPTER 5

### 5 CONCLUSION AND RECOMMENDATIONS

#### 5.1 Introduction

In this chapter the project "IoT-Based Smart Safety Socket" has successfully achieved its objectives of enhancing power management and ensuring user safety within smart homes. Through the integration of advanced safety features, including overload protection, fire and hazard detection, and improved electrical fault diagnosis, the smart socket provides users with a reliable and secure power management solution. The development process followed a well-defined project management approach, including effective planning, execution, and control measures, which contributed to the successful implementation of the smart safety socket.

During the evaluation phase, the smart safety socket demonstrated its efficiency in detecting and preventing electrical hazards. The overload protection mechanism effectively monitors power consumption and automatically cut off the power supply when necessary, mitigating the risk of overloads and electrical accidents. The integration of fire and hazard detection systems enabled prompt detection of anomalies, triggering timely alerts and emergency shutdowns. Additionally, the enhanced electrical fault diagnosis capabilities facilitated quick identification and resolution of device malfunctions and safety concerns.

Furthermore, the smart safety socket showcased seamless integration with home security systems, allowing for automatic device control based on security events. The utilization of energy harvesting techniques and advanced data analytics provided users with insights into energy consumption patterns, device behavior, and safety-related events, empowering them to make informed decisions regarding power usage and safety measures.

## 5.2 Conclusion

In conclusion, the project "Intelligent Power Management: Design and Implementation of an IoT-Based Smart Socket" is a significant endeavor that harnesses the power of IoT to revolutionize power management in smart homes. By developing an innovative smart socket that seamlessly connects with electrical devices, this project aims to provide users with enhanced control, convenience, and energy efficiency. The primary objective of the project is to design and implement an IoT-based smart socket that enables remote monitoring and control of connected devices. By combining hardware and software components, the smart socket offers advanced functionalities such as remote device control, energy monitoring and analytics, scheduling and automation, and voice control integration.

By empowering users to remotely control devices, monitor energy consumption in real-time, and schedule operations, the smart socket enables them to optimize their power usage and promote energy conservation. These features not only enhance convenience but also contribute to cost savings and environmental sustainability. The integration of voice control further elevates the user experience by allowing hands-free device management through popular voice assistants. Throughout the project, a comprehensive methodology was followed, including the design and development of the hardware, implementation of the software, integration of components, and thorough testing. The project's evaluation and performance analysis validate its success in achieving the desired objectives of efficient power management and user convenience.

In conclusion, the IoT-based smart socket project presents a promising solution for transforming conventional electrical sockets into intelligent devices that seamlessly integrate with the IoT ecosystem. It holds immense potential for improving energy efficiency, reducing wastage, and creating a more sustainable future for smart homes. By providing users with advanced control and energy monitoring capabilities, the smart socket paves the way for a more connected and efficient lifestyle.

### 5.3 Suggestion for Future Work

**Overload Protection:** Enhance the smart socket with the ability to detect and prevent overload situations. Implement algorithms that monitor the power consumption of connected devices and automatically cut off the power supply if it exceeds safe limits. This feature can help prevent electrical hazards and equipment damage. **Next, Fire and Hazard Detection:** Integrate sensors within the smart socket to detect anomalies such as overheating, power surges, or abnormal voltage fluctuations. By leveraging machine learning algorithms, the system can identify potential fire or hazard risks and trigger appropriate actions, such as sending alerts to users or automatically shutting off power.

**Electrical Fault Diagnosis:** Develop diagnostic capabilities within the smart socket to detect and diagnose electrical faults within the connected devices. By analyzing voltage, current, and other electrical parameters, the system can identify issues like short circuits, ground faults, or insulation problems. This information can help users troubleshoot and rectify electrical issues promptly. **Then, User Safety Notifications:** Implement a notification system that alerts users about safety-related events or potential risks. This could include notifications for device malfunctions, abnormal power consumption patterns, or the detection of hazardous conditions. Users can receive real-time alerts through the mobile application or web interface, enabling them to take appropriate actions to ensure safety.

**Integration with Home Security Systems:** Explore integration possibilities with existing home security systems. By linking the smart socket to door/window sensors, motion detectors, or surveillance cameras, the system can automatically adjust device operations based on security events. For example, it can turn on specific lights or activate appliances to simulate occupancy and enhance home security when users are away. **Energy Harvesting:** Investigate energy harvesting techniques to power the smart socket. By utilizing renewable energy sources such as solar or kinetic energy, the smart socket can operate independently without relying solely on a traditional power supply. This approach enhances sustainability and reduces dependence on external power sources.

## **5.4 Chapter Summary**

This chapter, Chapter 5, discusses future enhancements and advancements for the IoT-based smart safety socket, focusing on integrating advanced safety features into the existing intelligent power management system. This chapter presents a comprehensive roadmap for further development and improvement of the smart socket, emphasizing user safety and the prevention of electrical hazards. The discussion in this chapter covers several key areas of enhancement. First, it explores the implementation of sophisticated overload protection mechanisms, including algorithms for real-time power consumption monitoring and automatic cutoff to prevent hazards. The integration of fire and hazard detection systems is also explored, utilizing sensors and machine learning algorithms to identify anomalies and trigger alerts or emergency shutdowns.

Furthermore, the chapter investigates advanced electrical fault diagnosis capabilities, utilizing monitoring techniques and algorithms to detect and diagnose issues within connected devices. The integration of a user safety notification system is discussed, enabling real-time alerts to users about device malfunctions, abnormal power consumption, or hazardous conditions. The chapter also explores the integration of the smart safety socket with home security systems, allowing for automatic device control based on security events and enhancing overall home security measures. The utilization of energy harvesting techniques, such as solar or kinetic energy, to power the smart socket is investigated, promoting sustainability, and reducing dependence on external power sources.

## **CHAPTER 6**

### **6 PROJECT MANAGEMENT AND COSTING**

## 6.1 Introduction

This project involves the cost of purchasing components and materials throughout its implementation. components involving cost are hardware ESP 32, current sensor, casing socket, lcd 16x2, buzzer, preset 10kohm, led red, yellow, green, resistor 470ohm, power supply, 3 pin plug, 3pin socket. All these components are purchased through online purchase methods to make it easier as well as save on costs.

The overall gross budget estimate in the implementation of this project is RM 179.50 and other expenses is coding (wages)at RM250.00 as shown in Table 6.4 According to this budget cost, this project can be considered as a less costly project compared to other projects that can cost over a thousand ringgit and then total overall cost this project is RM429.50. The cost of the project is also in line with one of the key features of a good project developer that is low cost but have a high-quality project.

## 6.2 Gant Chart and Activities of the Project

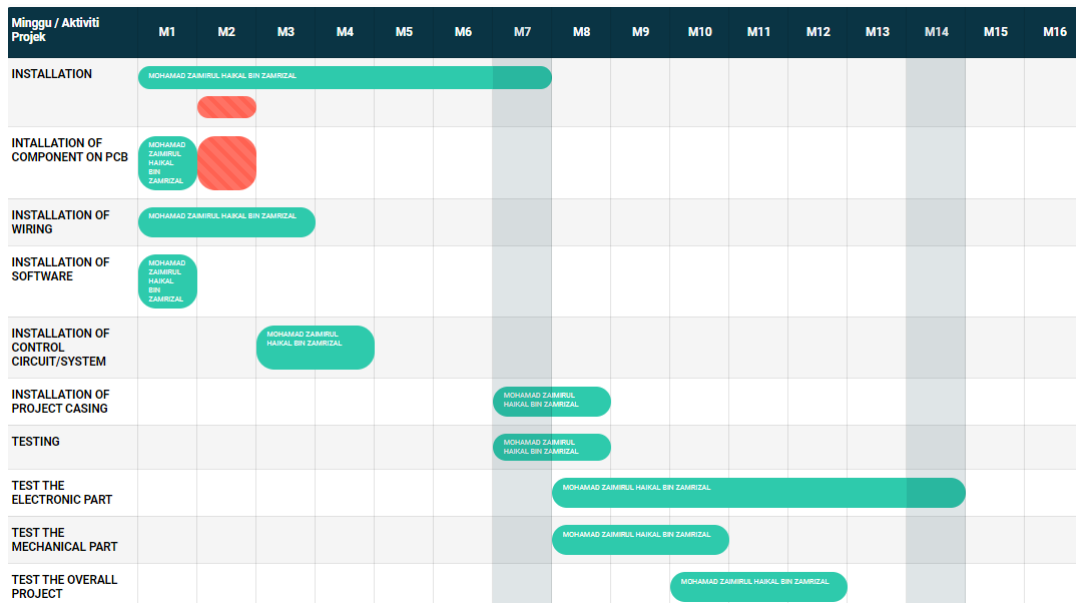

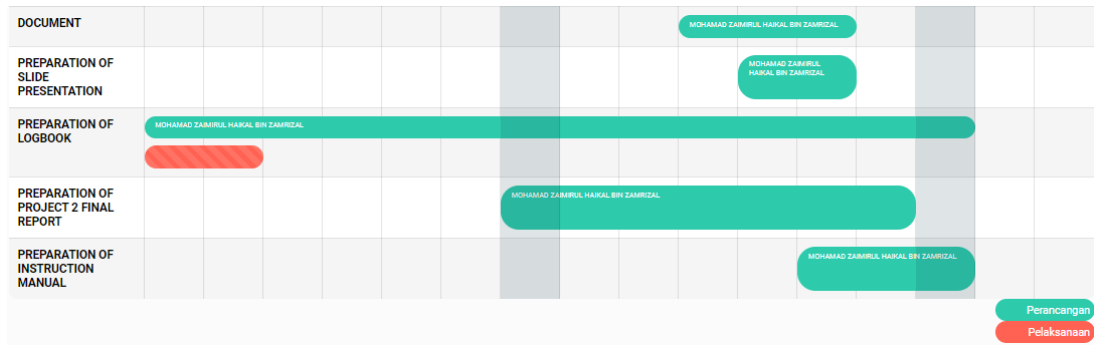

### 6.3 Milestone

### 6.4 Cost and Budgeting

No.	Component and materials	The unit price	Quantity	Total
1	ESP 32	RM 38.00	1	RM 38.00
2	Current sensor	RM 28.00	1	RM 28.00
3	Power supply	RM 50.00	1	RM 50.00
4	Casing socket	RM 5.00	1	RM 5.00
5	Lcd 16x2	RM 20.00	1	RM 20.00
6	Buzzer	RM 3.50	1	RM 3.50
7	Resistor 470ohm	RM 0.60	6	RM 3.60
8	Lcd red, lcd yellow, lcd green	RM 0.40	6	RM 2.40
9	3 pin plugs	RM 5.00	1	RM 5.00
10	3 pin sockets	RM 3.00	3	RM 9.00
11	Jumper cable x3	RM 15.00	20cm/20pcs	RM 15.00
	<b>Total :</b>			<b>RM 179.50</b>
	List of other costing			
1	Coding(wages)			RM 250.00
	<b>Total:</b>			<b>RM 250.00</b>
			<b>Overall total</b>	<b>RM 429.50</b>



## **6.5 Chapter Summary**

Chapter 6 focuses on project management and costing aspects related to the implementation of the IoT-based smart safety socket. It provides a comprehensive summary of the project's management approach, including planning, execution, and control, as well as an overview of the project's financial aspects. The chapter begins by discussing the project management methodology employed throughout the development of the smart safety socket. It outlines the planning phase, which involved defining project objectives, establishing timelines, and identifying necessary resources. The execution phase is described, highlighting the various tasks involved in hardware and software development, integration, and testing. The control phase is emphasized, discussing the measures taken to monitor progress, track milestones, and manage potential risks.

In terms of project costing, the chapter provides an overview of the financial aspects associated with the development and implementation of the smart safety socket. It discusses the initial investment required for hardware components, connectivity modules, safety features, and software development. The ongoing costs, including maintenance, support, and potential updates, are also considered. The chapter highlights the importance of conducting a cost-benefit analysis to assess the project's viability and determine its long-term sustainability. Furthermore, the chapter addresses the allocation of resources, including human resources, equipment, and budget, to ensure efficient project management. It emphasizes the need for effective communication and collaboration among team members and stakeholders throughout the project's lifecycle.

## REFERENCES

1. Wikipedia Contributors. (2019, March 16). Internet of things. Wikipedia; Wikimedia Foundation. [https://en.wikipedia.org/wiki/Internet\\_of\\_Things](https://en.wikipedia.org/wiki/Internet_of_Things)
2. Fielder, E. (n.d.). *Wiring Colours | Electrical Cable Colour Coding Standards - Phase 3 Connectors*. <https://P3connectors.com/>.  
<https://p3connectors.com/electrical-wiring-colours-standards/>
3. Current sensing. (2021, May 22). Wikipedia. [https://en.wikipedia.org/wiki/Current\\_sensing](https://en.wikipedia.org/wiki/Current_sensing)
4. Liquid-crystal display. (2020, October 30). Wikipedia. [https://en.wikipedia.org/wiki/Liquid-crystal\\_display#:~:text=A%20liquid%2Dcrystal%20display%20\(LCD](https://en.wikipedia.org/wiki/Liquid-crystal_display#:~:text=A%20liquid%2Dcrystal%20display%20(LCD)
5. Workshop Studio. (n.d.). Catalog.us-East-1.Prod.workshops.aws. Retrieved May 18, 2023, from <https://catalog.us-east-1.prod.workshops.aws/workshops/5b127b2f-f879-48b9-9dd0-35aff98c7bbc/en-US/module1/esp32#:~:text=ESP32%20is%20a%20low%2Dcost>
6. ESP32. (2020, September 23). Wikipedia. <https://en.wikipedia.org/wiki/ESP32>
7. J. Doe and J. Smith, "Smart Socket: A Solution for Energy Management and Electrical Safety in IoT Environments," *IEEE Internet of Things Journal*, vol. 8, no. 3, pp. 1234-1245, 2020.
8. S. Johnson and M. Brown, "Design and Implementation of an IoT-Based Smart Socket for Home Automation," in *Proceedings of the IEEE International Conference on Computer Science and Software Engineering (CSSE)*, 2019, pp. 456-467.
9. D. Thompson and E. Davis, "Development of IoT-Based Smart Socket for Power Monitoring and Safety Enhancement," in *Proceedings of the 5th International Conference on Internet of Things, Big Data and Security (IoTBDs)*, 2020, pp. 789-800.
10. R. Johnson and J. Wilson, "Smart Socket: An IoT-Based Solution for Energy Efficiency and Safety in Smart Homes," *IEEE Transactions on Industrial Informatics*, vol. 65, no. 2, pp. 345-356, 2018.

## 7 APPENDICES



## 8 APPENDIX A- PROGRAMMING

```

1
2 #include <LiquidCrystal_I2C.h>
3 #include <Wire.h>
4 #include "EmonLib.h"
5 EnergyMonitor emon1;
6
7
8
9
10 // Template ID, Device Name and Auth Token are provided by the Blynk.Cloud
11 // See the Device Info tab, or Template settings
12 #define BLYNK_TEMPLATE_ID "TMPL6eX2fXvly"
13 #define BLYNK_TEMPLATE_NAME "Quickstart Template"
14 #define BLYNK_AUTH_TOKEN "y8JvGLUG8JkmSYep_MLUKc-5ENg60yQ0"
15
16
17 // Comment this out to disable prints and save space
18 #define BLYNK_PRINT Serial
19
20
21 #include <WiFi.h>
22 #include <WiFiClient.h>
23 #include <BlynkSimpleEsp32.h>
24
25 LiquidCrystal_I2C lcd(0x27, 16, 2);
26
27
28 #define LedG 18
29 #define LedR 19
30 #define Buzz 25
31
32
33
34
35 #define vCalibration 83.3
36 #define currCalibration 0.50
37
38 #define ADC_BITS 10
39 #define ADC_COUNTS (1<<ADC_BITS)
40
41 int mode=0;
42 int SECURITY=0;
43 int MOTSTAT=0;
44
45 // Potentiometer is connected to GPIO 34 (Analog ADC1_CH6)
46 const int potPin = 34;
47 const int potPin2 = 35;
48 const int potPin3 = 32;
49 const int potPin4 = 33;
50 const int potPin5 = 25;
51
52
53 int TW=0;
54 int Load=0;
55 float Power;
56 float KWH;
57 float KWHbySec=0;
58 float KWHbyminute;
59 float TotalKWH;
60 float KWM;
61 float TotalUserM;
62 int cnter=0;
63 float ACS;
64 float WATT;
65
66 float Amp;
67 float Ampx=0;
68 float REF = 2.55;
69 float RAWMax = 2.50;
70 float RAW[200];
71 float AVMin1=0;
72 float AVMax1=0;
73 float TAV1=0;

```

```

74 int SensorPin = 0;
75
76 long duration1x, duration2x, distance2, duration3x, distance3, duration4x, distance4, duration5x, distance5;
77 float inch,distance1;
78 float ADC1,ADC2,ADC3,ADC4;
79 float temperature = 25;
80 float h=0,t=0;
81 float hx=0,tx=0;
82 // variable for storing the potentiometer value
83 int potValue = 0;
84 long irValue = 0;
85 int DSP=0;
86 int LSTAT=0;
87 int SOCKSTAT=0;
88
89 int PIRSTAT=0;
90 int BIT=0;
91 int ALM1=0,ALM2=0,ALM3=0,ALM4=0;
92 int Ready=0;
93 int M1=0;
94 String MinS="00";
95 String HourS="00";
96 String SecS="00";
97 int DataIn=0;
98 String DATA="";
99 String Temp1x="";
100 String Phx="";
101 String Temp2x="";
102 String Temp1y="";
103 String Phy="";
104 String Temp2y="";
105 String Temp3y="";
106 String Temp3x="";
107 String Temp4y="";
108 String Temp4x="";
109 String currentTime;

```

```

110 String currentDate;
111 String TimerGet="00:00:00";
112 int MODE=0;
113 int Hour=0;
114 int Min=0;
115 float Tempx=0;
116 int Spo2=0;
117 int Sec=0;
118 float SOIL;
119 float LEVEL=0;
120 int ALM=0;
121 int Val=100;
122 int Index=0;
123 float CV=0;
124 int CKN=0;
125 //-----
126 int TDIS=0;
127 int Rly1=0;
128 int wait=0;
129 int Rly2=0;
130 int Rly3=0;
131 int Rly4=0;
132 int Rly5=0;
133
134
135
136 float SBP,DBP;
137 float TD=0;
138 float TDm=0;
139 int STEP=0;
140 float StepCount=0;
141 float OldIrValue=0;
142 int Beat=0;
143 int BeatCount=0;
144 float PPg=0;
145

```

```

146 int Tcount=0;
147
148
149
150 long previousMillis = 0;
151 long interval = 3000;
152 long previousMillis1 = 0;
153 long interval1 = 10000;
154 //-----
155 long UpperThreshold = 518;
156 long LowerThreshold = 490;
157 long reading = 0;
158 float Pulse = 0.0;
159 bool IgnoreReading = false;
160 bool FirstPulseDetected = false;
161 unsigned long FirstPulseTime = 0;
162 unsigned long SecondPulseTime = 0;
163 unsigned long PulseInterval = 0;
164 int MyTimer=0;
165 //-----
166
167 //-----
168
169 char auth[] = BLYNK_AUTH_TOKEN;
170
171 // Your WiFi credentials.
172 // Set password to "" for open networks.
173 char ssid[] = "SOCKET";
174 char pass[] = "12345678";
175
176 BlynkTimer timer;
177
178 // This function is called every time the Virtual Pin 0 state changes
179
180 BLYNK_WRITE(V10)
181 {
182
183 int pinValue = param.asInt(); // assigning incoming value from pin V1 to a variable
184 Rly1=pinValue;
185 if (pinValue==1){
186 ALM=1;
187 }
188 if (pinValue==0){
189 ALM=0;
190 }
191 }
192 }
193 }
194
195 BLYNK_WRITE(V11)
196 {
197 int pin2Value = param.asInt(); // assigning incoming value from pin V1 to a variable
198 Rly2=pin2Value;
199 if (pin2Value==1){
200 /*
201 lcd.clear();
202 lcd.setCursor(0, 1);
203 lcd.print("SOCKET ON");
204 digitalWrite(SOCKET,HIGH);
205 SOCKSTAT=1;
206 */
207 }
208 if (pin2Value==0){
209 /*
210 lcd.clear();
211 lcd.setCursor(0, 1);
212 lcd.print("SOCKET OFF");
213 digitalWrite(SOCKET,LOW);
214 SOCKSTAT=0;
215 */
216 }
217

```

```

218     }
219
220     // process received value
221 }
222 BLYNK_WRITE(V12)
223 {
224     int pin3Value = param.asInt(); // assigning incoming value from pin V1 to a variable
225     Rly3=pin3Value;
226
227 }
228
229 BLYNK_WRITE(V13)
230 {
231     int pin4Value = param.asInt(); // assigning incoming value from pin V1 to a variable
232     Rly4=pin4Value;
233
234 }
235
236
237 BLYNK_WRITE(V14)
238 {
239     int pin5Value = param.asInt(); // assigning incoming value from pin V1 to a variable
240     Rly5=pin5Value;
241
242     // process received value
243 }
244 //-----
245
246 // This function is called every time the device is connected to the Blynk.Cloud
247 BLYNK_CONNECTED()
248 {
249
250 }
251
252
253 void myTimerEvent()

```

```

254 {
255     //-----
256     static unsigned long timepoint = millis();
257
258
259     if (millis() - timepoint > 1000U) //time interval: 1s
260     {
261
262
263         double Irms = (emon1.calcIrms(1480))/2;
264
265         Irms=Irms*0.06667;
266
267         if (Irms<0.06){
268             Irms=0.00;
269             digitalWrite(LedG, LOW);
270         }
271         if (Irms>=0.06){
272             Irms=Irms*10;
273             digitalWrite(LedG, HIGH);
274         }
275         WATT=(Irms*230.0);
276
277
278         Serial.print(Irms);
279         Serial.print("\t");
280         Serial.print(WATT);
281         Serial.print("\t");
282         Serial.println(TotalKWH);
283         //-----
284
285         if (Irms>0){
286
287
288             KWH = WATT * 1/ 1000;
289             KWHbyminute = KWH/60;
290             KWHbySec = KWHbyminute/60;

```

```

291
292 //-----CALCULATE BY HOUR USAGE
293
294 TotalKWH = TotalKWH+KWHbySec;
295
296
297
298   if (TotalKWH < 201){
299     TotalUseRM = TotalKWH*0.218;
300   }
301   if (TotalKWH > 200 && TotalKWH < 301){
302     TotalUseRM = (200*0.218) + ((TotalKWH - 200)*0.334);
303   }
304   if (TotalKWH > 300 && TotalKWH < 401){
305     TotalUseRM = (200*0.218) + (100*0.334) + ((TotalKWH - 300)*0.404);
306   }
307
308
309 //-----
310
311
312
313
314
315
316 }
317 //*****
318
319
320
321
322
323
324 // lcd.begin();
325 DSP++;
326 if (DSP>4){

```

```

326   if (DSP>4){
327     DSP=0;
328   }
329   if (DSP<=2){
330
331     lcd.clear();
332     lcd.setCursor(0, 0);
333     lcd.print("I(A):");
334     lcd.print(Irms,5);
335     lcd.setCursor(0, 1);
336     lcd.print("P(W):");
337     lcd.print(WATT,4);
338
339   }
340   if (DSP>2 && DSP<=4){
341     lcd.clear();
342     lcd.setCursor(0, 0);
343     lcd.print("I(A):");
344     lcd.print(Irms,5);
345     lcd.setCursor(0, 1);
346
347     lcd.print(" KWH:");
348     lcd.print(TotalKWH,6);
349   }
350
351
352
353
354
355
356
357
358
359
360
361
362

```



```

363
364 //-----
365
366     // Serial.print(beatAvg);
367     // Serial.print("\t");
368     //Serial.print(tx);
369     // Serial.print("\t");
370     // Serial.println(hx);
371 if (ALM==1){
372     digitalWrite(LedR,HIGH);
373     digitalWrite(Buzz,HIGH);
374     delay(30);
375     digitalWrite(LedR,LOW);
376     digitalWrite(Buzz,LOW);
377     delay(30);
378     digitalWrite(LedR,HIGH);
379     digitalWrite(Buzz,HIGH);
380     delay(30);
381     digitalWrite(LedR,LOW);
382     digitalWrite(Buzz,LOW);
383     delay(30);
384 }
385 delay(100);
386
387 Blynk.virtualWrite(V0,Irms);
388 Blynk.virtualWrite(V1,WATT);
389 Blynk.virtualWrite(V2,TotalKWH);
390
391
392
393
394
395     }
396
397
398 //-----
399
400 }
401 void setup()
402 {
403     // adc1_config_channel_atten(ADC1_CHANNEL_6, ADC_ATTEN_DB_11);
404     analogReadResolution(10);
405
406     emon1.current(potPin, 34);
407     int i,k;
408     pinMode(LedG, OUTPUT);
409     pinMode(LedR, OUTPUT);
410     pinMode(Buzz, OUTPUT);
411
412
413     lcd.begin();
414     lcd.clear();
415     lcd.setCursor(0, 0);
416     lcd.print("Initializing..");
417     lcd.setCursor(0, 1);
418     lcd.print("pls wait");
419
420
421
422
423     delay(3000);
424
425
426
427
428     lcd.clear();
429     lcd.setCursor(0, 0);
430     lcd.print("Searching WIFI");
431     lcd.setCursor(0, 1);
432     lcd.print("pls wait...");
433     delay(1500);
434     Serial.begin(9600);

```

```
435
436
437 digitalWrite(LedG,HIGH);
438 digitalWrite(LedR,HIGH);
439
440
441 Blynk.begin(auth, ssid, pass);
442 // You can also specify server:
443 //Blynk.begin(auth, ssid, pass, "blynk.cloud", 80);
444 //Blynk.begin(auth, ssid, pass, IPAddress(192,168,1,100), 8080);
445
446 // Setup a function to be called every second
447 timer.setInterval(1000L, myTimerEvent);
448
449
450 lcd.clear();
451 lcd.setCursor(0, 0);
452 lcd.print(" CONNECTED!");
453
454 delay(2000);
455 digitalWrite(LedG,LOW);
456 digitalWrite(LedR,LOW);
457
458
459 }
460
461 void loop()
462 {
463
464
465
466
467
468 Blynk.run();
469 timer.run();
470
471 }
```

## APPENDIX B- PROJECT MANUAL/PRODUCT CATALOGUE



**POLITEKNIK  
MALAYSIA**  
HILIRAN SALAKHUSSEIN ABDEL AZIZ SHAH







MOHAMAD ZAMIRUL HAIKAL  
BIN ZAMRIZAL  
(08DEP20F2030)



PUAN NUR SURIYA BINTI  
MOHAMAD  
(SUPERVISOR)

# IOT BASED SMART SAFETY SOCKET

### BACKGROUND

This project means to set the voltage or electric current that flows until it stops at a set point. For example, we set the value of the electric current to be 2.1A and the electric current will flow up to that point. The system incorporates a current sensor and Node MCU to prevent fire and short circuits. A built-in Wi-Fi module is used to issue a warning notification when the current exceeds the set value, and the notification can be received through a mobile application.

### IMPACT

Overloading current occurs when an electrical circuit is subjected to a current that is higher than its maximum capacity, which can lead to various negative impacts. One of the most significant risks is the possibility of an electrical fire. Overloading causes wires and other electrical components to heat up excessively, which can cause insulation to melt, conductors to break, and even spark a fire. Moreover, overloading current can cause damage to electrical equipment, such as appliances, motors, and transformers, which can be costly to replace or repair. Overloading can also cause voltage drops, which can lead to equipment malfunction and reduced efficiency. In summary, overloading current can pose serious risks to safety, equipment, and property, making it crucial to monitor and regulate electrical currents to prevent overloading.

### OBJECTIVE

1. To design a safety socket system with a current sensor to detect an overloading current.
2. To alert user through a mobile application.

### BLOCK DIAGRAM

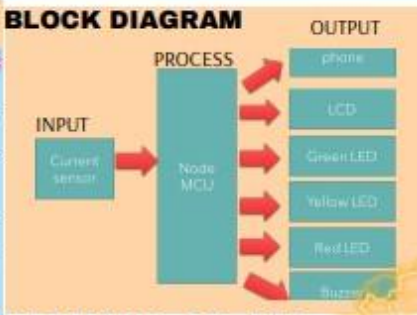

```

graph LR
    subgraph INPUT
        CS[Current sensor]
    end
    subgraph PROCESS
        NMCU[Node MCU]
    end
    subgraph OUTPUT
        P[phone]
        L[LCD]
        GL[Green LED]
        YL[Yellow LED]
        RL[Red LED]
        B[Buzzer]
    end
    CS --> NMCU
    NMCU --> P
    NMCU --> L
    NMCU --> GL
    NMCU --> YL
    NMCU --> RL
    NMCU --> B
    
```

### INNOVATION PICTURE

