



**POLITEKNIK SULTAN SALAHUDDIN ABDUL  
AZIZ SHAH**

**JABATAN KEJURUTERAAN MEKANIKAL**

**SESI 2:2022/2023**

<b>NAME</b>	<b>MATRIX</b>
<b>AIDIL HAKIMI BIN CHE NASARUDDIN</b>	<b>08DKM20F2038</b>
<b>AFIQ AHLAMI BIN ASMAWI</b>	<b>08DKM20F2010</b>
<b>MARYAM NABILA BINTI RIDZOOLDIN</b>	<b>08DKM20F2020</b>

**JABATAN KEJURUTERAAN MEKANIKAL**

**PNEUMATIC CAN CRUSHER**

**DECLARATION OF ORIGINALITY**

**We confirmed that the proposal report we are submitting are entirely our own work that any material used from other source has been clearly identified and properly acknowledged and referenced.**

**Project Title: Smart Automatic Watering**

**Author Signature:**

.....

**Author Name:**

**Registration No:**

**Date:**

**APPROVAL**

This proposal is submitted to the Department of Electrical Engineering as a partial fulfillment of the requirement for the Diploma in Electronic (Computer) Engineering. The supervisory committees are as follow:

Supervisor Signature:

.....

Supervisor Name: ENCIK AHMAD FAKARUDDIN BIN MOHD FAUZI

Date:

# **TABLE OF CONTENT**

## **CONTENT PAGE**

**PROJECT TITLE**

**DECLARATION OF ORIGINALITY**

**ACKNOWLEDGEMENT**

**ABSTRACT**

**CHAPTER 1: INTRODUCTION**

**1.0 INTRODUCTION**

**1.1 PROBLEM STATEMENT**

**1.2 OBJECTIVE**

**1.3 SCOPE**

**CHAPTER 2: LITERATURE REVIEW**

**2.1 INTRODUCTION**

**2.2 PREVIOUS RESEARCH**

**2.2.1 PRODUCT A**

**2.2.2 PRODUCT B**

**2.2.3 PRODUCT C**

**2.3 COMPONENTS**

**2.3.1 DOUBLE ACTING-CYLINDERS**

**2.3.2 AIR COMPRESSER**

**2.3.3 POLYTHYLENE TUBING**

## **CHAPTER 3: METHODOLOGY**

### **3.1 INTRODUCTION**

### **3.2 PROJECT DESIGN**

#### **3.2.1 FLOW CHART**

#### **3.2.2 CONCEPT DESIGN AND EVALUATION**

#### **3.2.3 MATERIAL SLECTION AND PARTS**

#### **3.2.4 FABRICATION**

#### **3.2.5 MATERIALS AND TOOLS**

## **CHAPTER 4: FINDING AND DISCUSSION**

### **4.1 INTRODUCTION**

### **4.2 FINDINGS DATA**

### **4.3 INSTRUCTION MANUAL**

### **4.4 TEST RESULTS**

## **CHAPTER 5: CONCLUSION AND RECOMMENDATION**

### **5.1 INTRODUCTION**

### **5.2 CONCLUSION**

### **5.3 RECOMMENDATIONS**

### **5.4 LIMITATIONS**

### **5.5 SUMMARY**

## **GANT CHART**

## **ACKNOWLEDGEMENT**

We would like to express our sincere appreciation to Allah Almighty for granting us the opportunity to complete our Final Year Project. In addition, we would like to extend our heartfelt gratitude to Politeknik Sultan Salahuddin Abdul Aziz for providing us with the chance to pursue our Diploma in Mechanical Engineering courses. Furthermore, we would like to thank all the individuals who have assisted us throughout our diploma years. We are immensely grateful to our supervisor, Mr. Ahmad Fakaruddin Bin Mohd Fauzi, for his adept guidance from the beginning to the end of the report, and for dedicating his time to discuss and review our work. His vast knowledge and expertise were instrumental in helping us complete this research.

We would also like to express our appreciation and gratitude to our parents and family for their unwavering support, love, encouragement, and prayers, which have been a constant source of strength for us. Finally, we want to thank all our friends who have supported us throughout this semester, especially our team members Maryam Nabila, Afiq Ahlami, and Aidil Hakimi. We extend our gratitude to everyone who has helped us in completing our Final Year Project.

## **ABSTRACT**

In our review, we found that there are many problems in carrying out recycling activities by the parties involved, especially in the recycling industry. The process of recycling waste and used goods often requires a large area and a lot of manpower, especially in management work cans. Therefore, we have discussed to solve it and agreed that where the most critical problem is in the collection. among the objectives of our project is to redesign the existing product but by changing it using another method which is the pneumatic method. this will help to crush the can more easily. This machine will also help save costs, energy, and time. This project aims to design and build a pneumatic can crusher for recycling industry. The production process of this pneumatic can crusher begins with a design that is realized through orthographic drawing and isometric drawing using AutoCAD software. The raw material related has been identified and provided. Next, the fabrication process is done to build a pneumatic can crusher. Usability of this machine evaluated through Technical Data Test. Its effectiveness in terms of time to help will be assessed through Technical Data Testing. This machine also consists of important components, namely, pneumatic cylinders, solenoids, support plates, and several other parts.

## **ABSTRAK**

Dalam semakan kami, kami mendapati terdapat banyak masalah dalam menjalankan aktiviti kitar semula oleh pihak yang terlibat khususnya dalam industri kitar semula. Proses mengitar semula bahan buangan dan barangan terpakai selalunya memerlukan kawasan yang luas dan tenaga kerja yang ramai terutamanya dalam tin kerja pengurusan. Oleh itu, kami telah berbincang untuk menyelesaikannya dan bersetuju bahawa di mana masalah yang paling kritikal adalah dalam koleksi. antara objektif projek kami adalah untuk mereka bentuk semula produk sedia ada tetapi dengan mengubahnya menggunakan kaedah lain iaitu kaedah pneumatik. ini akan membantu untuk menghancurkan tin dengan lebih mudah. Mesin ini juga akan membantu menjimatkan kos, tenaga, dan masa. Projek ini bertujuan untuk mereka bentuk dan membina mesin penghancur tin pneumatik untuk industri kitar semula. Proses penghasilan mesin penghancur tin pneumatik ini bermula dengan reka bentuk yang direalisasikan melalui lukisan ortografik dan lukisan isometrik menggunakan perisian AutoCAD. Bahan mentah berkaitan telah dikenalpasti dan disediakan. Seterusnya, proses fabrikasi dilakukan untuk membina penghancur tin pneumatik. Kebolegunaan mesin ini dinilai melalui Ujian Data Teknikal. Keberkesanannya dari segi masa untuk membantu akan dinilai melalui Ujian Data Teknikal. Mesin ini juga terdiri daripada komponen penting iaitu silinder pneumatik, solenoid, plat sokongan dan beberapa bahagian lain.



# **CHAPTER 1**

## **INTRODUCTION**

### **1.0 INTRODUCTION**

The final project of this semester is one of the main things that need to be done implemented by semester 5 students to meet the course requirements as required to obtain a Diploma in Mechanical Engineering. For carry out this Final Project, everyone in the group must go through some procedures that have been set by the Malaysian Polytechnic Department of Education. At the initial stage, everyone in the group is given freedom to determine the project to be produced.

In this era, one of the most common garbage produced today is cans. Therefore, by recycling cans is a way that must be done with obligation because it can help reduce environmental pollution and the use of the number of raw materials. During this time, individuals who collect cans must smash the cans with their feet to allow the sack to be filled with more cans. When they use this method, after a long time they will hurt and must use so much energy. So, we decide to make a product that can help them.

For our final year project, we choose to produce a product that can make time saving, easy to use and safe for recycling worker which is pneumatic can crusher. The cost to build this product has been considered by making a difference between another model at the marketplace by differentiate the price, quality, efficiency, and durability. The product design is made for easy to do a maintenance each time it had to service.

Pneumatic is an operation that use a compressed air. By using a pneumatic system, it will move the actuator to compress the can. Basically, our project is using compress air to crush the can.

### **1.2 PROBLEM STATEMENT**

In the development of technology in our country now, various equipment and machines have been created to facilitate human work. Therefore, to

reduce the burden on those who collect cans, we have come up with the idea to modify and improve the existing design. The project we made to improve is the pneumatic can crusher.

Today's can collectors mostly collect cans from restaurants, playgrounds, recreation areas and roadsides before sending them to recycling plants. When they collect the cans, they need to crush the tin cans before the can get into the sack. The method that they use to make the can flat is by using their foot or hammer that must use much energy and can make their leg and back hurt. Also, it may take time to crush it one by one.

Beside the problem from the worker, the design that already at the marketplace are to slow and weak. Most can crusher out there are usually slow and can only crush a few cans per minute. By improving the weakness of existing machines which is making them faster, more efficient, and more powerful, we hope we can make a better can crusher.

Other than that, the design of other can crusher didn't have safety when worker want to use it and it can lead to harms for them.

By the all the problem that has been state, the idea of our pneumatic can crusher that has been decide by us can solve the problem.

## **1.1 OBJECTIVES**

A high-quality product must have good efficiency, durability, and effectiveness. To obtain a good level for our project, we have set specific objectives to be able to provide the best results at the end of the project completion.

The main objectives for our project implemented are as follows:

- i. To design and produce a cans crushing machine using a pneumatic cylinder.
- ii. To make it easier to crush cans.
- iii. To save cost, time, and energy.

### 1.3 SCOPES

Project scope is the limit for a product to operate. The project that we produced has a specific scope so that it is more functional focused and able to produce within the specified time. For this project scope we have decide that

- The funnel of the pneumatic can crusher machine can accommodate 40 cans at a time.
- The types of cans that can be checked are drink cans and food cans.
- The maximum speed of this can crusher is only crush 20 can per 30 sec.

Therefore, with the scope of the project that has been determined, we make it a point of reference to implement this project successfully. This stated scope is also an ability and capability for the project we build.

## CHAPTER 2

### LITERATURE REVIEW

#### 2.0 INTRODUCTION

To ensure that the machines produced have high efficiency, fast, fast quality and get a good response. Research is one of the steps that need to be done to produce a project.

we will identify some aspects and the force required to support and crush cans. this is to reduce the cost in terms of the main drive of the machine we designed. the force will be used to drive the pneumatic cylinder which is one of the important components of this machine.

#### 2.1 PREVIOUS RESEARCH

##### 2.2.1 Product A



Figure 2.1: Product A

This product uses a manual way to crush the can but using with our hand. The design is also more ergonomic where after the can has been crush, the plate below can automatically open to release the can falling. This can crusher still requires the use of human power to operate it. In total, this product can fill up to 19 cans per minute.

### 2.2.2 Product B



Figure 2.2: Product B

This product is using an electrical power to crush a can. This can crusher uses a 120v ac powered line actuator, where it crushes the cans that are in the crushing chamber to crush the cans. there is a hole at the end of the can holder chamber where once the can is pressed it will fall down or into the container. This can opener uses a remote control to operate it. There is also a sensor at the end of the actuator and also an optical sensor to determine when the condition can be crush and the condition of the can entering the crushing chamber. The downside to this product is that it takes a long time to fill the cans one by one.

### 2.2.3 Product C



Figure 2.3: Product C

This product uses feet to crush the cans. This product can make cans from as small as 12oz up to 20oz only. It not only compresses aluminium cans but can also compress steel cans. its disadvantage is that it cannot compress cans to be smaller. In addition, it is also difficult to use compared to vertical can crushers, even more so in large quantities

**TABLE 2.1:CRITERIA COMPARISON**

	<b>DESIGN A</b>	<b>DESIGN B</b>	<b>DESIGN C</b>
<b>RESISTANCE</b>	<b>8/10</b>	<b>6/10</b>	<b>3/10</b>
<b>EFFICIENCY</b>	<b>9/10</b>	<b>7/10</b>	<b>5/10</b>
<b>MACHINE SIZE</b>	<b>Medium</b>	<b>Big</b>	<b>Small</b>
<b>MANUFACTURING COST</b>	<b>RM400</b>	<b>RM310</b>	<b>RM260</b>
<b>LOAD BEARING CAPACITY</b>	<b>40</b>	<b>10</b>	<b>1</b>

## **2.3 COMPONENTS**

In this literature review, we have also done some research on the component parts that we will use in implementing this project.

### **2.3.1 DOUBLE ACTING –CYLINDERS**

A double-acting pneumatic cylinder has two ports that control the movement of the rod. The compressed air causes the rod to move in two directions by extending and retracting without the assistance of a spring. This type of pneumatic cylinder is essential for any applications that need control of movement in two directions.

Double-acting cylinders (DAC) use the force of air to move in both extend and retract strokes. They have two ports to allow air in, one for outstroke and one for instroke. Stroke length for this should be performed as well design is not limited, however, the piston rod is more vulnerable to buckling and bending.



Figure 2.4: Double Acting Cylinders

Cylinder diameter: 50 mm

Piston rod diameter: 20 mm

Stroke length: 60 mm

Theoretical force: 990 N

### 2.3.2 ROLLER VALVE

Roller Lever Valves are used to actuate the movement of Pneumatic Cylinders.

In the absence of electrical supply, manually operated valves such as Roller Lever Valves are used. The functioning is the same, however, the solenoid coil is replaced by a Rolling lever, which actuates the movement of air inside the valve, and out to the Cylinder.

a wide range of roller lever valves of a variety of brands, in 1/4" size.

This component is used for the automatic mechanism.



Figure 2.5: Direction Control Valve

### 2.3.3 AIR FLOW CONTROL VALVE

Function

- These valves allow controlled flow of air in one direction and free flow in the other direction.

Application

- These valves are used to control the speed of piston in a pneumatic cylinder



Figure 2.6: Air flow Control Valve

### 2.3.4 SILENCER

Silencers are used to reduce the noise of the exhaust air.

#### FEAUTRERS

- Brass body and sintered bronze silencer elements
- Button, Conical, Silencer cum flow control (with lock nut), Silencer cum flow control (with spring) types
- Good flow and silencing characteristics
- Can be cleaned by kerosene and soap water



Figure 2.7: Silencer



### 2.3.5 QUICK COUPLER

This can be effectively used in all compressed air line applications

- Some of them Include

- All compressed air lines.
- Assembly lines with pneumatic tools / Machinery with pneumatic systems
- Pneumatic control panels.

### 2.3.6 AIR COMPRESSOR

An air compressor is a device that converts power (usually from an electric motor, a diesel engine or a gasoline engine) into kinetic energy by compressing and pressurizing air, which, on command, can be released in quick bursts.

A reciprocating compressor or piston compressor is a positive-displacement compressor that uses pistons driven by a crankshaft to deliver gases at high pressure. The intake gas enters the suction manifold, then flows into the compression cylinder where it gets compressed by a piston driven in a reciprocating motion via a crankshaft, and is then discharged.



Figure 2.8: Air Compressor

### 2.3.7 POLYETHYLENE TUBING

Poly tubing, often referred to as PE tubing or polyethylene tubing is a flexible, lightweight, durable and corrosion resistant plastic that can be used for a wide range of liquid, gas and fluid transfer applications. Poly tubing is also FDA approved for use in food and beverage applications. Polyethylene tube is completely safe and is one of the most common PE tubing materials in the world.

#### Differences Between Polyurethane & Polyethylene Tubing

Polyurethane is a highly stretchable material. It provides excellent flexibility, heat resistance and cracking and puncture protection, which means that it is highly useful for applications that must withstand harsh environments. Conversely, polyethylene provides increased moisture protection, while maintaining good strength and durability features. Since it is FDA approved, poly tubing is often used within the food and beverage industries.



Figure 2.9: Polyethylene Tubing

### 2.3.8 5/2 WAY VALVE



A 5/2-way solenoid valve has five ports and two positions. It can be either normally closed or normally open. When the valve is energized, it switches from one position to the other, allowing fluid to flow through the different ports. On the other hand, a 5/3-way solenoid valve has five ports and three positions.

## **CHAPTER 3: METHODOLOGY**

**(MARYAM NABILA BINTI RIDZOOLDIN)**

### **3.1 INTRODUCTION**

The methodology's primary purpose is to show the process of making product. This chapter consists of starting from details about product design, materials and tools, techniques used to build products and innovations that can be done from previous products that are currently on the market.

### 3.2 PROJECT DESIGN

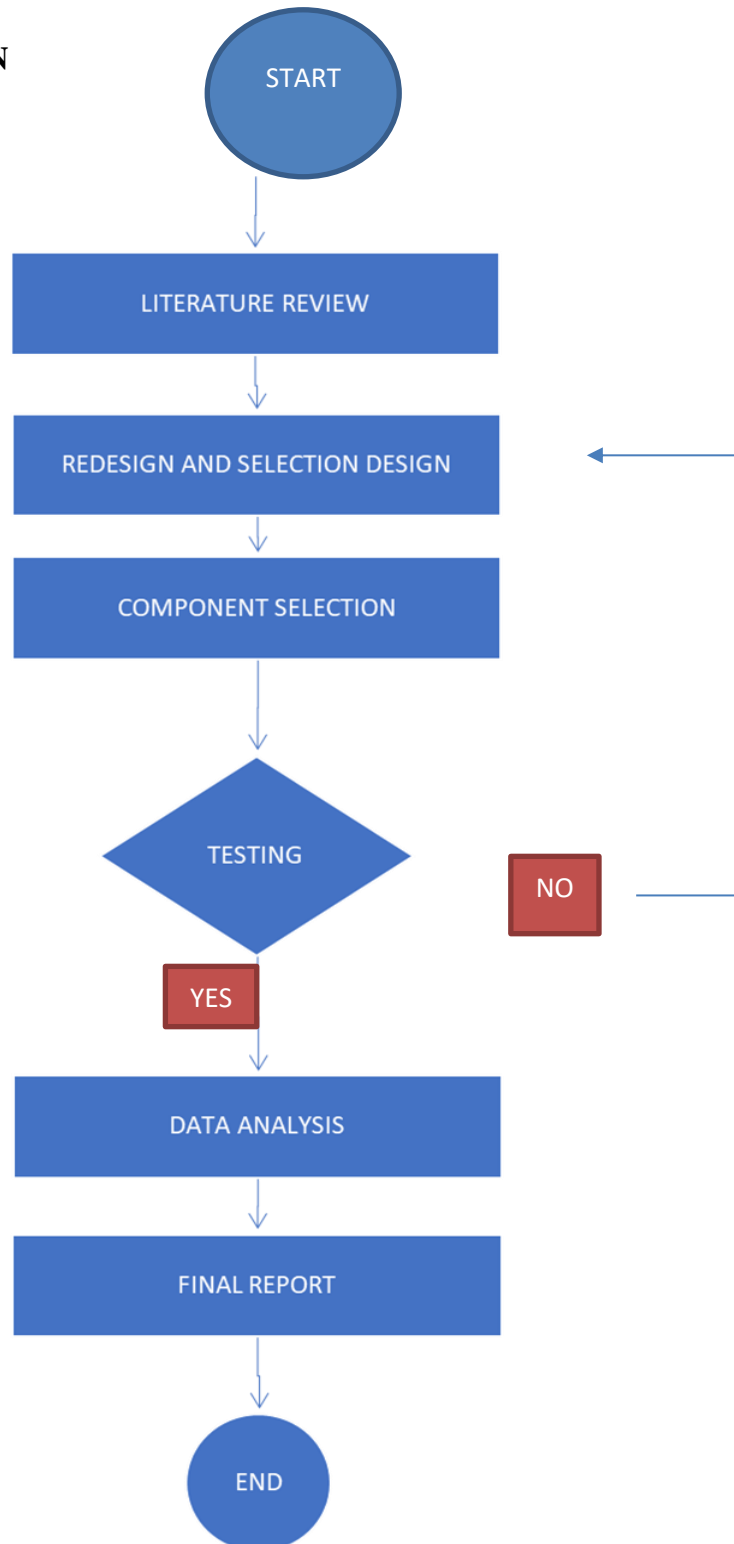

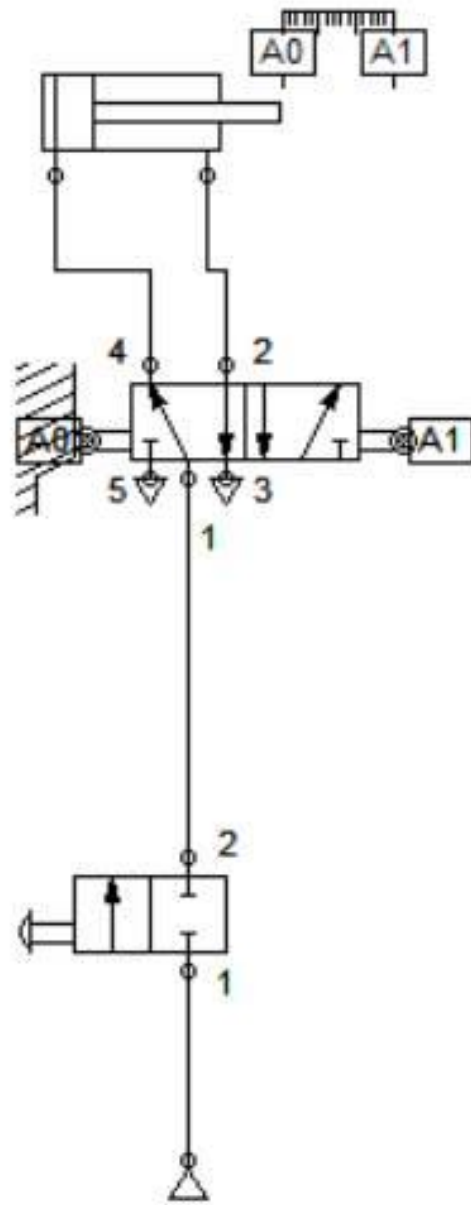

### 3.2.1 CONCEPT DESIGN AND EVALUATION

In this process each of group member design their own Pneumatic can crusher with different concept using sketching . After the design was completed, we made an evaluation for each of the design and choose the best design and work concept.

#### Concept “A”

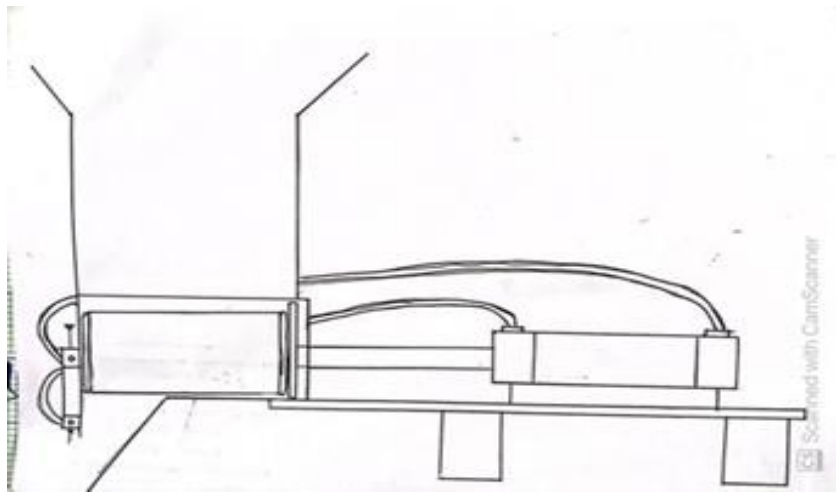
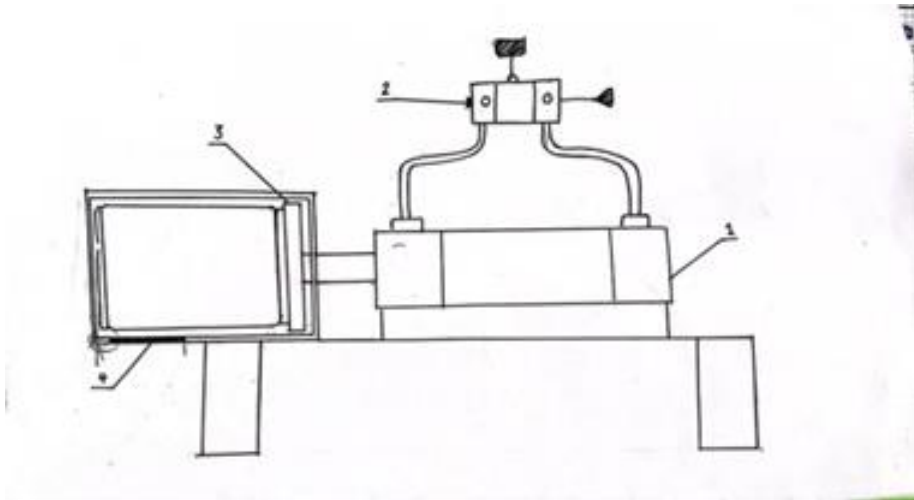

Figure 3.1: Design Concept A

The concept design of this design displays the position of the pneumatic cylinder in a horizontal state. This design also places a large funnel at the top that allows many empty cans to be placed at one time.

## Concept “B”



**Figure 3.2:Design Concept B**

Concept design B shows the position of the pneumatic cylinder is the same as design A which is horizontal. but there is a difference in the place to insert the drink can. this design does not have a funnel. this allows it to insert only one can at a time.



**Concept “C”**

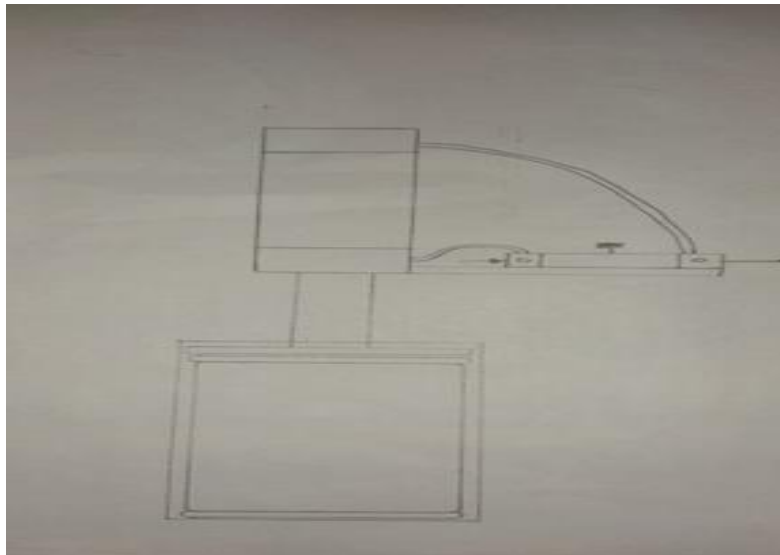

Figure 3.3:Design Concept C

	<b>DESIGN A</b>	<b>DESIGN B</b>	<b>DESIGN C</b>
<b>RESISTANCE</b>	<b>8/10</b>	<b>6/10</b>	<b>3/10</b>
<b>EFFICIENCY</b>	<b>9/10</b>	<b>7/10</b>	<b>5/10</b>
<b>MACHINE SIZE</b>	<b>Medium</b>	<b>Big</b>	<b>Small</b>
<b>MANUFACTURING COST</b>	<b>RM400</b>	<b>RM310</b>	<b>RM260</b>
<b>LOAD BEARING CAPACITY</b>	<b>40</b>	<b>10</b>	<b>1</b>

Table 3.1 ;comperassion Table

### **3.2.2 MATERIAL SELECTION AND PARTS**

Before fabrication process, we need to decide what material should be use for each part of the components. Material selection are important because it help to determine the resilience of the product when it is fabricated. Strength and durability of the product is taken into account to prevent the product from failing during testing in project 2 and data collection process. These are the parts and material used for the parts.

#### **Hollow Steel**



The term Hollow Structural Sections (HSS) refers to high-strength welded steel tubing used as structural elements in buildings and other structures and a variety of manufactured products. It is produced in round, square and rectangular shapes and a broad range of sizes to the ASTM A500, A1085, and A1065 specifications.

## **BOLT AND NUT**



Nuts are almost always used in conjunction with a mating bolt to fasten multiple parts together. The two partners are kept together by a combination of their threads' friction (with slight elastic deformation), a slight stretching of the bolt, and compression of the parts to be held together.

## **METAL PLATE**

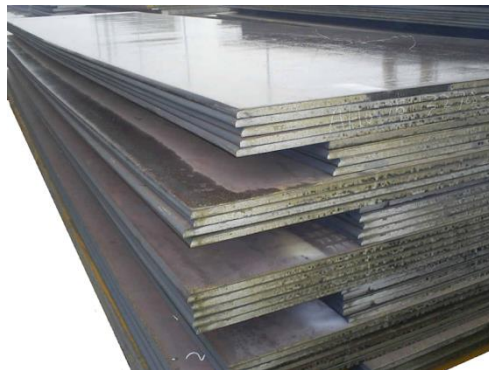

Plates are thick slabs of metal that are normally used for structural purposes. Available from Continental Steel in a number of different materials, plates are usually cut as their size makes them difficult to shape or bend. Titanium Plates.

### 3.2.3 FABRICATION

After designing phase, fabrication processes take place. These processes are about using material selection and make the product base on the design and by followed the design dimension. Many methods can be used to fabricate a product, like welding, cutting, bending, grinding, drilling and many more methods. Fabrication process is a process to make only one product rather the manufacturing process was used at the whole system production. This way include part by fabrication until assembly to other components.

To make the design come reality, fabrication process needs to be done first. The fabrication process starts from dimensioning the raw material until we finish as a desire product. The processes that involve are:



- **MEASURING AND MARKING**

After getting the material, the next step is measurement and marking material like Fig3.13. The equipment used in this process is measuring tape or steel rule and scriber all the components are marked as per required dimensions.



- **CUTTING MATERIAL**

After the measurement and marking process, figure 4.3 introduce the process cutting the material using metal cut off saw.

On the cutting machine, we cut the materials for making the desired shape and sizes of L- angular, fixed plate



- **DRILLING**

Drilling is the most common machining process whereby the operation involves

making round holes in metallic and nonmetallic materials.

After cutting the material, it is need to make holes for the parts like wooden sheet, clamps, frame, by different drill bits. So, mark the position to drill using steel rule and scribe and then punch a small hole by using Centre punch before start drill. After that, start the drilling.



- **WELDING**

**MIG welding** is a type of welding that uses a welding power supply to create an electric arc between an electrode and the base material to melt the metals at the welding point. By using this we make the frame and the handle

- **GRINDER**



We use this tool to smooth the surface of the metal after the welding process we

made. This process really helps for finishing process to make it visual better rather than all the bumps after the welding process.

### **AUTOMATIC MECHANISM**

The project has a lot of fabrication in and out of the crushing chamber. To put in words, we must add on a lot of hollow steel to make the body, with that we also add more elevation to put on the funnel. By doing this it created space between the opening of the funnel and the crushing chamber.

The automatic mechanism work with two roller valves on two sides of the body, by the attaching a steel rod that already been customized to two roller valves. One valve will make the pneumatic hydraulic go forward and one valve to make it return to the original placement. At the end of it, we created an automated pneumatic system that can be run with one push of a button.

### **3.2.4 MATERIALS AND TOOLS**

**Table 3.2: materials and tool cost**

DESCRIPTION	QUANTITY	UNIT PRICE	TOTAL
Pneumatic cylinder	1	129.60	129.60
Tube 8mm	3m	3.20	9.60
Tube 6mm	6m	2.00	12.00
3/2 way roller valve	2	45.00	90.00
3/2 way push button	1	45.00	45.00
5/2 way double air pilot	1	66.80	66.80
Straight male connector 1/8	10	2.20	22
Straight male connector ¼	3	2.30	6.90
Steel plate 40cm*50cm	1	72.00	72.00
Mild steel hollow 1m	6	80.00	80.00
		SUBTOTAL	533.90



## CHAPTER 4

### FINDING AND DISCUSSION

#### 4.1 INTRODUCTION

In this chapter, we will introduce and finish it with all our data collection and our discussion for our final year project. The data collection will be our stepping stone for our project either it will be a success or failure project. In summary of our data collection after the presentation it appears our project was functional but does not achieve our objective.

#### 4.2 FINDINGS DATA

The most common way to finding data is going through survey with the public people to get their opinion towards our project. In this way we will get more knowledge about the project we made does it have a good purpose and functionality in the recycling department. We also went and asked an operator at a local Recycling site in Shah Alam to put his own thoughts about this project.

In his opinion the project is a good idea for our final year project course but it has a lot of flaws in the real world for the Recycling department. First of is “who will be the user of it?”, because the Recycling department has way much better equipment for crushing all the cans in a one way or another. The person also states that the cost to make this equipment with pneumatic component is a high cost by building it and to maintain it. Last words from him, the idea is a good one but does not convince in all other ways for this project.

#### 4.3 INSTRUCTION MANUAL



Figure 4.1



1. First turn on the air compressor to collect the required pressure of air



Figure 4.2

2. turn on the valve to let the compressed air to flow through the polymeric tube that already connected with prepared pneumatic circuit.



Figure 4.3

3. Press the push button the let the air flow with the prepared circuit

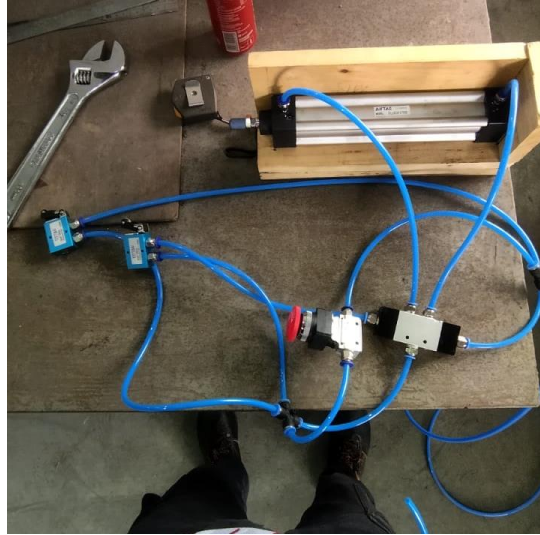

Figure 4.4

4. The prepared pneumatic circuit must be prepared properly and safe from any leak of air



Figure 4.5

5. Let the pneumatic crush the desired can inside the crushing chamber
6. To stop the pneumatic can crusher reset the push button

## 4.4 TEST RESULTS

The test results were showing the action that we desired, pneumatic was staying in place while the crushing process was commence. We tested on different type of can drinks, each of them has different height and diameters. In summary, the crushing process was low on success because of the different type of size cans.



- this type size of can was suitable and showed a perfect crush



- This size of can drinks wasn't crush properly

## **CHAPTER 5**

### **RECOMMENDATION**

#### **5.1 INTRODUCTION**

For this chapter we will arrange our discussion, conclusion and recommendation for our project to build it better and put out a better idea in the future. All our inspection for this project will be put out with the test run we made even if it's a failure we will be express it in discussion of it. Finally, depending on the outcome of the discussion and the improvement plan that has been developed.

#### **5.2 CONCLUSION**

For the conclusion of our project, this idea of our project is already been used many times from the past. The reason the project mostly didn't work because of the funnel that put on the body of the project wasn't construct well enough. If this can be improved the work flow will be a success from the beginning before the crushing is made and the end of the crushing process. If this improvement can be presented well and great it will be success with the convincing in the market.

The funnel idea must have a great construction and mechanism inside it to improve the work flow, with this it will be related with reliability and efficiency. We will explain how reliability and efficiency is important for the outcome of our project, by using data and inspection from our own project with the test run data. From the test we made only 1 out 5 cans were crushed perfectly, it shows that the efficiency of our project does not has a high rate of successful. By witnessing the test, it appears the can were stuck in between and doesn't fit and inline perfectly when the crushing process. For reliability, it shows that the success rate is low and doesn't achieve our objective to crush cans with the desired target.

According our own opinion and the lectures opinion it must have a better idea to pick up the success rate from 10% to 100% to make the project work well with a great flow of the process. A better idea is on the funnel part and in other fabrication on the project. Despite the failure we do achieve the mechanism that we desired; the mechanism is to be automated with the perfect inline from the starting can into the next can to be crushed.

### **5.3 RECOMMENDATION**

Based from our conclusion and discussion, the recommendation that to be point out must be better and has a good purpose in the future.

- Funnel must have a much more ideas inside to make a better flow for the crushing point.
- Safety hazard must improve in the future; safety from the crushing process.
- Mechanism section must be fabricated perfectly to touch the switch all the time.
- Finishing must work on the project to pull the audience and to have a good view of the project.

### **5.4 LIMITATIONS**

The limitations for our project is that we only can fit one size can drink, the others can that we want to include it does not fit in the chamber. Other can size we want to include is food can and bigger can drink, in other words all the cans that can be crushed with the power of pneumatic cylinder.

### **5.5 SUMMARY**

End of this report is to summarize the project, it was failure because it does not achieve the objective that stated. The only success is the construct of the project and the mechanism of it. We hope the pneumatic can crusher can get carried by new semester student to put on their ideas to make it work and put in the market.

