

**POLITEKNIK SULTAN
SALAHUDDIN ABDUL AZIZ SHAH**

SMART POST BOX

**MOHAMAD AMIRUL ASYRAF BIN MD YUNUS
(08DJK19F2008)**

**PN.WAN NORHIDAYAH BINTI WAN
MOHAMED NOR**

JABATAN KEJURUTERAAN ELEKTRIK

SESI 1 2022/2023

**POLITEKNIK SULTAN
SALAHUDDIN ABDUL AZIZ SHAH**

SMART POST BOX

**MOHAMAD AMIRUL ASYRAF BIN MD YUNUS
(08DJK19F2008)**

**PN.WAN NORHIDAYAH BINTI WAN
MOHAMED NOR**

JABATAN KEJURUTERAAN ELEKTRIK

SESI 1 2022/2023

CONFIRMATION OF THE PROJECT

The project report titled "SMART POST BOX" has been submitted, reviewed and verified as a fulfills the condition and requirements of the Project Writing as stipulated.

Checked by:

Supervisor's name :

Supervisor's signature :

Date :

Verified by:

Project Coordinator name :

Signature of Coordinator :

Date :

“ I acknowledge this work is my own work except the excerpts I have already explained to our source”

1. Signature

Name :

Registration Number :

Date :

DECLARATION OF ORIGINALITY AND OWNERSHIP

SMART POST BOX

1. I, **MOHAMAD AMIRUL ASYRAF BIN MD YUNUS (NO KP: 010510-01-1009)** is a final year student of **Diploma in Control Electronics Engineering,**

Department of Electrical, Politeknik Sultan Salahuddin Abdul Aziz Shah, which is located at **Persiaran Usahawan , 40150 Shah Alam Selangor.**

(Hereinafter referred to as 'the Polytechnic').

2. I acknowledge that 'The Project above' and the intellectual property therein is the result of our original creation/creations without taking or impersonating any intellectual property from the other parties.
3. I agree to release the 'Project' intellectual property to 'The Polytechnics' to meet the requirements for awarding the **Diploma in Control Electronic Engineering** to me.

Made and in truth that is recognized by;

MOHAMAD AMIRUL ASYRAF BIN MD YUNUS)

(Identification card No.: 010510-01-1009)) MOHAMAD AMIRUL
ASYRAF BIN MD YUNUS

In front of me, PN.WAN NORHIDAYAH BINTI WAN MOHAMED
NOR(821125-14-5106)

As a project supervisor, on the date:)

.

ACKNOWLEDGEMENT

I have taken efforts in this Project. However, it would not have been possible without the kind support and help of many individuals and organizations. I would like to extend my sincere thanks to all of them. I am highly indebted to PN. WAN NOR HIDAYAH BINTI WAN MOHAMED NOOR for his guidance and constant supervision as well as for providing necessary information regarding the Project & also for their support in completing the Project.

I would like to express my gratitude towards my parents & my classmates for their kind co-operation and encouragement which help me in completion of this Project. I would like to express my special gratitude and thanks to industry persons for giving me such attention and time.

My Thank and appreciations also go to my colleague in developing the Project and people who have willingly helped me out with their abilities.

ABSTRACT

This project was implemented based on monitoring of current methods of mailboxes, mail that has been sent and placed in mailboxes that loses and abandoned by users. The objective of this project is to design a handy mailbox that can help to solve this problem. The scope of the research that have been set for this project is buildings such as condominiums, apartments, high-rise office buildings and shopping mall lot. There are several solutions for this issue which are users will be alert of the presence of parcel or letter and receives notifications through their phone. This project are using a " ARDUINO UNO " and also " GSM " material as a connector between sensors and battery. In addition, the battery is used to supply electrical energy for the mailbox to make it function. Next, the sensor used to detect the presence of the letter and parcel. When a letter or parcel is inserted into the mailbox, the sensor will detect the entry. The sensor alerts the GSM cloud to send the user a message through the message on the user's phone. As the results, the Smart Post Box has fully functioned and achieved the objectives as per discussed. Based on the survey that has been conducted, the Smart Post Box help users to solve the problems stated.

ABSTRAK

Projek ini dilaksanakan berdasarkan pemantauan keadaan semasa peti mel, mel yang dihantar dan diletakkan dalam peti mel yang sering hilang dan ditinggalkan oleh pengguna. Objektif projek ini adalah untuk mereka bentuk peti mel yang berguna untuk membantu menyelesaikan masalah ini. Skop kajian yang telah ditetapkan untuk projek ini adalah kondominium, pangsapuri, bangunan pejabat tinggi dan lot pusat beli-belah. Terdapat beberapa penyelesaian kepada masalah ini iaitu pengguna akan berwaspada dengan kehadiran bungkusan atau surat dan menerima mesej melalui telefon mereka. Projek ini menggunakan bahan " ARDUINO UNO " dan juga " GSM " sebagai penyambung antara sensor dan bateri. Selain itu, bateri digunakan untuk membekalkan tenaga elektrik untuk peti mel berfungsi. Seterusnya, sensor yang digunakan untuk mengesan kehadiran surat atau bungkusan. Apabila surat atau bungkusan dimasukkan ke dalam peti mel, sensor akan mengesan kemasukan bungkusan atau surat. Sensor memberi amaran kepada GSM untuk menghantar mesej kepada pengguna melalui mesej pada telefon pengguna. Hasilnya, Peti Surat Pintar telah berfungsi sepenuhnya dan mencapai objektif yang dibincangkan. Berdasarkan tinjauan yang telah dijalankan, Smart Post Box membantu pengguna menyelesaikan masalah yang dinyatakan. .

TABLE OF CONTENTS

CONFIRMATION OF THE PROJECT	3	
DECLARATION OF ORIGINALITY AND OWNERSHIP	4	
ACKNOWLEDGEMENTS	5	
ABSTRACT	6	
ABSTRAK	7	
TABLE OF CONTENTS	8	
LIST OF TABLES	10	
LIST OF FIGURES	11	
CHAPTER 1	12	
1 INTRODUCTION	12	
1.1 Introduction	12	
1.2 Background Research		12
1.3 Problem Statement	13	
1.4 Research Objectives	14	
1.5 Scope of Research	14	
1.6 Project Significance	14	
1.7 Chapter Summary	14	
CHAPTER 2	15	
2 LITERATURE REVIEW	15	
2.1 Introduction	15	
2.2 Literature Review Topic 1	15	
2.3 Literature Review Topic 2	15	
2.4 Literature Review Topic 3	16	
2.5 Literature Review Topic 4	16	
2.6 Literature Review Topic 5	16	
2.7 Chapter Summary	17	
CHAPTER 3	18	
3 RESEARCH METHODOLOGY		18
3.1 Introduction		18
3.2 Project Design and Overview		
3.2.1 Block Diagram of the Project	19	
3.2.2 Flowchart of the Project 2	19	

3.2.3 Project Description	19
3.3 Project Hardware	20
3.3.1 Schematic Circuit	20
3.3.2 Description of Main Component	20
3.3.2.1 Arduino Uno	21
3.3.2.2 Ultrasonic Sensor	22
3.3.2.3 Keyes SIM800C GSM	22
3.3.2.4 LCD Display 16x2	23
3.3.2.5 Buzzer	23
3.4 Project Software	24
3.4.1 Flowchart of the System	25
3.4.2 Description of Flowchart	26
3.5 Prototype Development	26
3.5.1 Mechanical Design/Product Layout	27
3.6 Chapter Summary	27
CHAPTER 4	28
4 PROJECT MANAGEMENT AND COSTING	28
4.1 Introduction	28
4.2 Gant Chart and Activities of the Project	28
4.3 Cost and Budgeting	29
4.4 Chapter Summary	30
REFERENCES	31
5 APPENDICES	32
APPENDIX A- PROGRAMMING	32-33
APPENDIX B- GANT CHART OF THE PROJECT	34

CHAPTER 1

1 INTRODUCTION

1.1 INTRODUCING

A Smart Post Box is a place that is used by the community to collect letters and also to receive parcels from the sender. The primary purpose of a Smart Post Box is to serve as a storage facility for letters or parcels until they are picked up by the receiver. Next, the old way of sending letters from home to house, which keeps us waiting, demonstrates that mail delivery services are inefficient. Furthermore, traditional Smart Post Box are subjected to inclement weather, which can cause damage to letters or packages. Then, especially in Malaysia's equatorial climate, which is hot, humid, and rainy all year, letters might be damaged. As a result, shipments can become lost. According to Seah Kah Hean, the current traditional mailbox system is unable to notify users of essential letters or shipments, resulting in considerable delays in replying to letters. The existing system's biggest problem is that we have to check each other's mailboxes on a regular basis. However, due to normal obligations or unforeseen situations, the mailbox may not be able to check every day. Last but not least, this Smart Post Box is intended to assist folks who do not often check their mails. The postman only needs to place the letter or parcel in the mailbox, and phone will receive a notification that something is in the mailbox. When the Smart Post box is full, it will make a sound to indicate that the mailbox is full. After the package is arrived, the packaging will auto be sanitized in the mailbox.

1.2 Background Research

Given how busy people are nowadays, it's easy to let minor details fall by the wayside. Many people have difficulty performing simple actions such as opening their mailbox. A simple job like opening your mailbox is something that many people overlook due to forgetfulness. It is, however, difficult to ignore a notification about. You can locate mail in your virtual mailbox. Integrating real and virtual mailboxes is beneficial, especially because many crucial letters are sent in a specific physical shape. As part of digitization and the internet of things, a networked house is a logical step forward (IOT). Incorporating a smart mailbox into a smart home is a small but essential step toward this goal. This thesis seeks to broaden understanding of various reading/scanning approaches, particularly as they apply to letters. There's also some suggestions on how to make ordinary tasks "smarter" by automating them.

1.3 Problem Statement

i. Waste Time

If the mailbox is outside the house, it might take a time to collect their postage or letter. If they are waiting for important postage, they might check the mailbox regularly. It is frustrated if they come from the high floor and looking from their postage, but the postage is not there yet or the mailbox is empty.

ii. People Busy With Daily Life

People is too busy working from morning and come back home at night. Sometimes they forgot to check whether the mailbox has postage or letter in it. People also tried to check the mailbox regularly and the mailbox are often located outside the house as they must walk to check the mailbox.

iii. The Viruses Can Quickly Infect Everyone.

We already have a delivery service centre, but we don't know whether or not the items have already been sanitized there.

iv. Anyone Can Steal The Postage

The user sometimes are too busy and sometimes the user not at home in long time period. The possibility of others people to steal are high and maybe the mail or postage are very important to the user.

1.4 Research Objectives

- To make it easy for people who aren't at home or who are at work to find out when their items have arrived.
- You will receive an SMS notification when the deliver or letter is delivered to the mailbox.
- To design Smart Post Box automatically sanitize.
- To test evaluate whether the Smart House System is fully functioned.

1.5 Scope of Research

This project is suitable for the high residential locations such as apartment buildings, condominiums, companies school and other environments. When products are stolen from the mailbox, our project focuses on consumers who buy online. Lastly, the main controller is using Arduino Uno.

1.6 Project Significance

The goal of this project is to create a Smart Post Box. In this context, "smart" refers to the ability to notify the recipient that mail has been received. Second, the Smart Post Box has automatic sanitizers to prevent the transmission of viruses that emerge nowadays. The goal is to create a product that demonstrates that the concept is viable and functional in the future, and the solution is designed with residential or office buildings in mind.

1.7 Chapter Summary

In this first chapter, I addressed the background research for the original idea for the beginning of this project. Then I discovered the difficulties that are now taking place. I also displayed the project's objectives and removed the scope of the study I obtained from the objective study. Furthermore, the Smart Post Box, which has a sanitizer inside the box, can be extremely safe for users. As a result, we may say that Smart Post Box's required aims and objectives will be met. The project's literature will be presented in the next chapter.

CHAPTER 2

2 LITERATURE REVIEW

2.1 INTRODUCTION

2.2 Literature Review Topic 1

The Smart Mailbox

The purpose of this project is to create a smart mailbox. To develop a product that illustrates the concept's future feasibility and usability. The first step was to define a smart mailbox and distinguish which features were important and which were desirable. Finally, the scanning accuracy of this project was evaluated using ten scan tries.

2.3 Literature Review Topic 2

Intelligent Mailbox

The I-Box (Intelligent Mailbox) is a product that assists users to be more sensitive or alert with the presence of mails in the mailbox. To put it another way, the I-Box may help them to overcome their forgetful habit and checking their mailbox as a habit. Besides the other problem that has been occur can be overcome with the technology applied in the IBox. By all the research and survey, I-Box is the product that relevantly could help users.

It is useful for all residents in their daily life and makes their life more convenient.

2.4 Literature Review Topic 3

Smart Home System secure postage with notification (RFID)

This project will create a Smart Home System and secure postal notification. To incorporate the model's design into the Smart House System. The project's technique is then built utilising an Arduino Uno and secured with radio-frequency identification (RFID). Finally, when a letter is inserted into a mailbox, if the user swipes the RFID reader, the RFID reader will scan and detect detail and try to match, if not, the message will be sent to the user's smartphone. If the details match, the mailbox will open and the information will be sent to the user's smartphone.

2.5 Literature Review Topic 4

Smart post mailbox

Remote access device that allows a user to contact the mailbox control unit from a remote location to check the status of the mailbox. The technique of this project is the logical design of the smart postal mailbox, which comprises a software solution created in the Arduino integrated development environment and a database where sensor data is kept. Finally, the project's outcomes include detecting the presence of a consignment in the mailbox and ensuring communication between the database and the Arduino.

2.6 Literature Review Topic 5

A solar-powered IOT connected physical mailbox interfaced with smart devices.

The mailbox contains recharging circuitry to charge the battery from a solar panel, thus, no manual charging nor is the wiring of power supply near the mailbox required. Whenever the door of the mailbox is closed, the electronic device wakes-up from low power sleep mode, senses the existence of mail inside the mailbox using infrared reflectance sensor, and sends the data to a hub using BLE. The prototype of the proposed smart mailbox, the hub, smartphone app, Google Home interface, and web interface has been developed and tested successfully.

2.7 Chapter Summary

Because this project is about product innovation, the research method of choice was experimental testing. When this product is finished, it will be tested to evaluate how effective it

is at fixing the problem. Furthermore, this literature review aids in the establishment of a theoretical framework comprised of research concepts and hypotheses whose success can be evaluated, as well as providing information for research relevance and coherence.

CHAPTER 3

RESEARCH METHODOLOGY

3.1 INTRODUCTION

Research methodology refers to the techniques or tactics used to collect, select, process, and analyse information about a topic. The method is used to achieve the project's goal of contributing to a perfect outcome. This chapter will go over the detailed explanations required to finish and test this project.

3.2 Project Design and Overview



Figure 3.2.1: Block Diagram of the Project

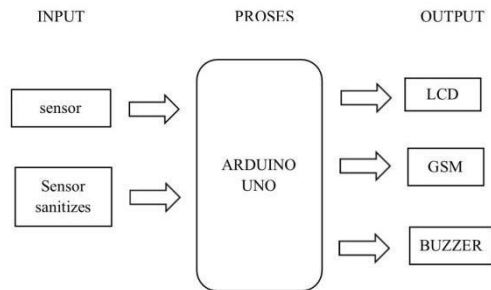

3.2.2 Flowchart of the Project 2

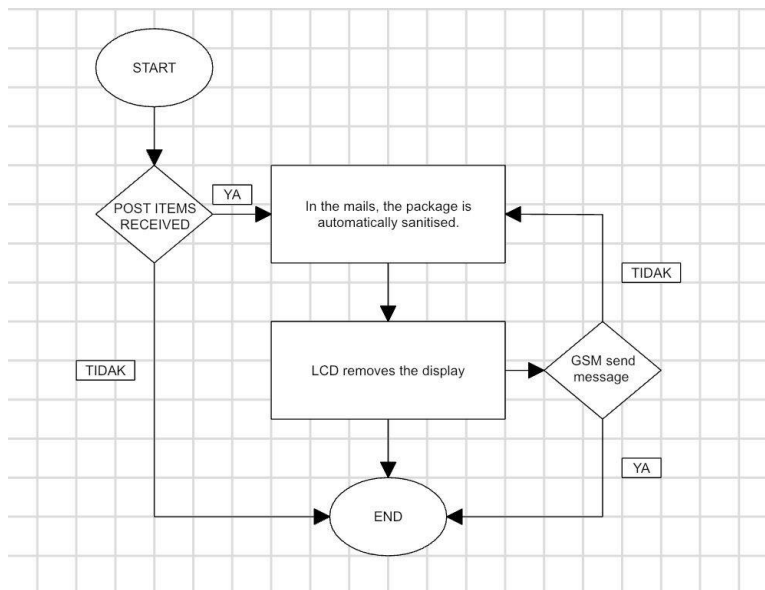

3.2.3 Project Description

For this project, when a letter or shipment arrives in the mailbox, a message is sent to phone users. In addition, the object will be automatically sanitised to avoid viruses. The item is also in good shape.

3.3.2.1 Arduino Uno

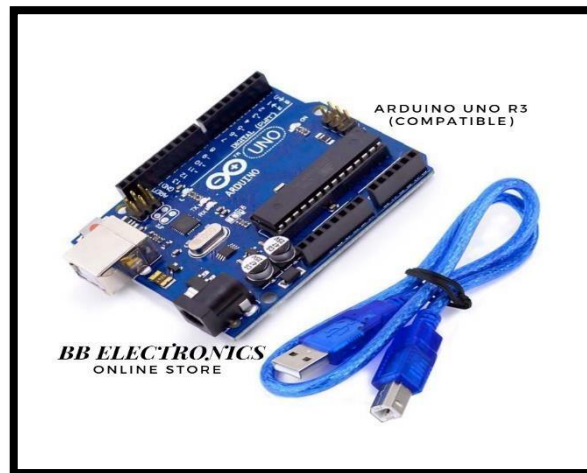

Arduino/Genuino Uno is a microcontroller board based on the Atmega328P. It has 14 digital input/output pins (of which 6 can be used as PWM outputs), 6 analog inputs, a 16 MHz quartz crystal, a USB connection, a power jack, an ICSP header and a reset button. It contains everything needed to support the microcontroller.

The Arduino Uno board can be powered via the USB connection or with an external power supply. The power source is selected automatically. External (non -USB) power can come either from an AC-to-DC adapter (wall-wart) or battery. The adapter can be connected by plugging a 2.1mm center-positive plug into the board's power jack. Leads from a battery can be inserted in the GND and Vin pin headers of the POWER connector.

Input and Output. Each of the 14 digital pins on the Uno can be used as an input or output, using `pinMode()`, `digitalWrite()`, and `digitalRead()` functions. They operate at 5 volts. Each pin can provide or receive 20 mA as recommended operating condition and has an internal pull-up resistor (disconnected by default) of 20-50k ohm. A maximum of 40mA is the value that must not be exceeded on any I/O pin to avoid permanent damage to the microcontroller.

3.3.2.2 Ultrasonic Sensor



An ultrasonic sensor is an electronic device that measures the distance of a target object by emitting ultrasonic sound waves, and converts the reflected sound into an electrical signal. Ultrasonic waves travel faster than the speed of audible sound (i.e. the sound that humans can hear). Ultrasonic sensors have two main components: the transmitter (which emits the sound using piezoelectric crystals) and the receiver (which encounters the sound after it has travelled to and from the target).

3.3.2.3 Keyes SIM800C GSM



This is a GPRS/GSM Arduino expansion board developed by Keyes. It is made up of EGSM 900MHz/DCS 1800MHz and GSM850 MHz/PCS 1900MHz. It is a shield module that combines GPRS and DTMF functions. When the DTMF function is enabled, the button pressed during the call can be converted into a character feedback, which can be used for remote control. It is controlled by the AT command, you can start its function directly through the computer serial port and the Arduino motherboard. SIMCom's SIM800H chip is embedded in the SIM800C GPRS Shield board for good stability.

SIM800C is a quad-band GSM/GPRS module that works on frequencies GSM850MHz, EGSM900MHz, DCS1800MHz and PCS1900MHz. SIM800C features GPRS multi-slot class10/class12 (optional) and supports the GPRS coding schemes CS-1, CS-2, CS-3 and CS-4. SIM800C is designed with power saving technique so that the current consumption is as low as 0.6mA in sleep mode.

3.3.2.4 LCD Display 16X2

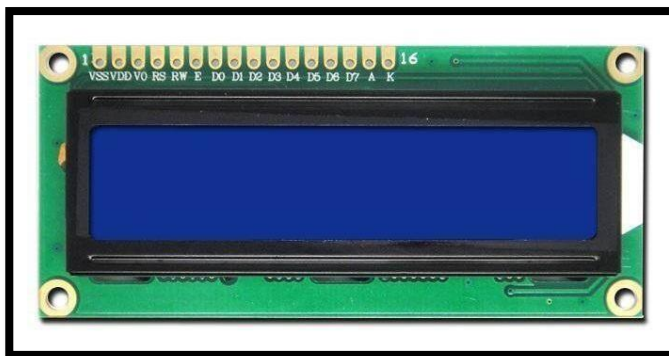

An LCD (Liquid Crystal Display) screen is an electronic display module and has a wide range of applications. A 16x2 LCD display is very basic module and is very commonly used in various devices and circuits. A 16x2 LCD means it can display 16 characters per line and there are 2 such lines. In this LCD each character is displayed in 5x7 pixel matrix. The 16 x 2 intelligent alphanumeric dot matrix display is capable of displaying 224 different characters and symbols. This LCD has two registers, namely, Command and Data.

3.3.2.5 Buzzer



An audio signaling device like a beeper or buzzer may be electromechanical or piezoelectric or mechanical type. The main function of this is to convert the signal from audio to sound. Generally, it is powered through DC voltage and used in timers, alarm devices, printers, alarms, computers, etc. Based on the various designs, it can generate different sounds like alarm, music, bell & siren.

3.4 Project Software

These project will use 2 development software:

i) Proteus

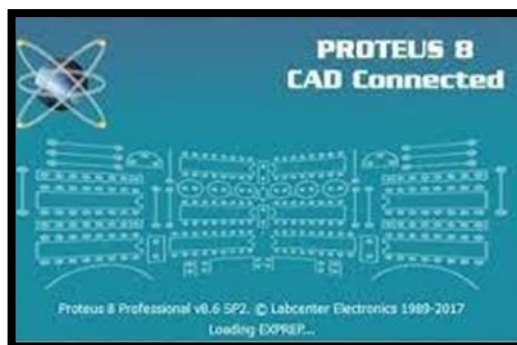

Proteus is a simulation and design software tool developed by Labcenter Electronics for Electrical. Used to draw schematic circuits for projects, make PCB circuit and also a place to do circuit simulations before producing circuits in hardware form. We can do a trial run on our project circuit so that no errors occur at the next stage

ii) Arduino Uno



Arduino IDE is an open-source software, designed by Arduino.cc and mainly used for writing, compiling & uploading code to almost all Arduino Modules. It is also used to insert the coding we have written into the Arduino UNO to make our project work the way we want. This software supports both C and C++ languages.

3.4.1 Flowchart of the System

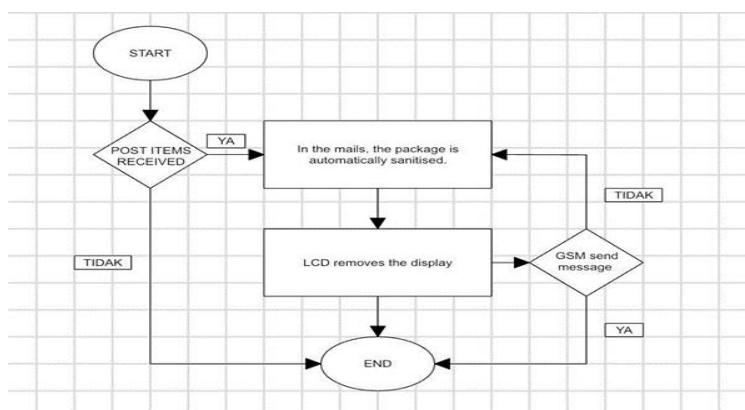

Figure 3.4.1: Flowchart of The System

3.4.2 Description of Flowchart

Any flow chart will begin with the 'Start' instruction. The hardware settings to offer Input/output will then be turned on using the adapter and batteries. The item in the mail will be detected by an ultrasonic sensor. Water pump sanitizer will clean. The LCD then says Thank You. Next After detecting an item, a notification will be issued to the owner. Finally, the flow chart will conclude with the command 'End.'

3.5 Prototype Development

The design of my project is the size should be suitable to be placed in the place that has been targeted. Especially in residential areas. This smart home mailbox was created to make it easier for people not to have to worry about whether the goods have arrived safely or not in the mailbox because when the goods have arrived, a notification will be sent by post. My target group in this project is people who are not often at home and people who are busy with outside things. This is because this type of person has limitations of movement and abilities. In addition, I also target the career group because they are always busy and have no time. So this smart home mailbox is specially created to make it easier for people to know that their goods are in a safe condition. This mailbox also has an auto sanitizer to prevent bacteria and viruses.

3.5.1 Mechanical Design/Product Layout

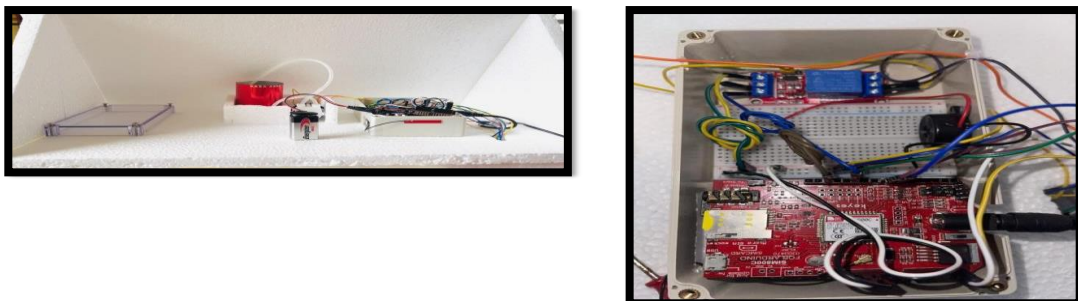

Figure 3.5.1: Mechanical Design / Product Layout

3.6 Chapter Summary

In this chapter of research methodology, each project will use a specific technique to assure its success and easy operation. This chapter describes the research structure, project completion strategies, and pertinent project components. The components are selected based on cost and function. It also provides an overview of the procedure and discusses the definitions and criteria used. This section also contains an overview of the schematic circuits and hardware projects, as well as the components used.

CHAPTER 4

PROJECT MANAGEMENT AND COSTING

INTRODUCTION

Project and Cost Management is one of the important parts as it describes and shows about the management made throughout the running of this project and presented through Gant Chart. This is very useful because we can clearly see the progress in doing this project, from planning and finding information about the project to be made until the project is completed according to plan. In addition, the cost of expenses is also explained to see the outflow of money and used to produce this project. We can see the cost of each component purchased and can estimate the budget for this project.

GSM, and other materials are cost-involved components. To make things easier and save money, all of these components are obtained through online purchasing methods.

LIST OF COMPONENT

No	Component Description	Quantity	Price/Unit	Total Price
1	Arduino UNO	1	RM 27.72	RM 27.72
2	Ultrasonic Sensor	1	RM 3.30	RM 3.30
3	Enclosure box	1	RM 14.82	RM 14.83
4	Male to female wire jumper	20	RM 0.50	RM 0.50
5	Female to female jumper wire	20	RM 0.50	RM 0.50
6	Water Pump	1	RM 3.90	RM 3.90
7	Buzzer	1	RM 3.00	RM 3.00
8	GSM	1	RM 53.60	RM 53.60
9	Mini Hand sanitizer	1	RM 2.00	RM 2.00
10	Breadboard	1	RM 2.70	RM 2.70
11	Relay	1	RM 3.50	RM 3.50
12	Adapter 12V 2A	1	RM 10.50	RM 10.50
13	Gabus	1	RM 10.00	RM 10.00
14	LCD 16x2	1	RM 10.60	RM 10.60
			Total: RM	RM 146.65
	List of other costing			
1	Postage			RM 10
2	Craft work			-
3	Internet			-
4	Application			-
			Total :	RM 10
			Overall Total	RM 156.65

Table 4.1: Costing and Budgeting

4.4 Chapter Summary

In this chapter, I detailed and created a Gant Chart that documented the progress of my project from start to finish. The expenses I incurred in order to purchase components and goods for this project are then explained. We can examine the pricing of each component as well as the project's other costs in great detail.

REFERENCES

1. B. Nath, F. Reynolds, and R. Want, "Rfid technology and applications," IEEE Pervasive computing, vol. 5, no. 1, pp. 22–24, 2006. DOI: 10.1109/MPRV.2006.13.
2. Sigfox. Dutch smart mailbox, Parcer, chooses Aerea SIGFOX-network. Available at: <https://www.sigfox.com/en/news/dutch-smart-mailbox-parcer-chooses-aereasingfox-network>
3. Pagati G , Priyanka.B , Harshal.M , Anirudha.P (2017) Implementation of Smart Letter Box System, ijarie,3 (1), 2395-4396.
4. X. Zhang, Q. Dong, and F. Hu, "Applications of rfid in logistics and supply overview," ICLEM 2012: Logistics for Sustained Economic Development— Technology and Management for Efficiency, pp. 1399–1404, 2012. DOI: 10.1061/9780784412602.0213.
5. Z Biru , D Nukuro , S Haghani (2018) The Design and Implementation of an Intelligent Letter Box, American Society for Engineering Education, University of the District of Columbia, Washington DC 47.
6. Elprocus. (n.d). Ultrasonic sensor. Retrieved 7th December 2018 from <https://www.elprocus.com/ultrasonic-detection-basics-application/>

APPENDICES

APPENDIX A - GANTT CHART

APPENDIX B – PROJECT COST

APPENDIX C – PROGRAMMING CODING PROJECT

APPENDIX B – PROJECT COST

LIST OF COMPONENT

No	Component Description	Quantity	Price/Unit	Total Price
1	Arduino UNO	1	RM 27.72	RM 27.72
2	Ultrasonic Sensor	1	RM 3.30	RM 3.30
3	Enclosure box	1	RM 14.82	RM 14.83
4	Male to female wire jumper	20	RM 0.50	RM 0.50
5	Female to female jumper wire	20	RM 0.50	RM 0.50
6	Water Pump	1	RM 3.90	RM 3.90
7	Buzzer	1	RM 3.00	RM 3.00
8	GSM	1	RM 53.60	RM 53.60
9	Mini Hand sanitizer	1	RM 2.00	RM 2.00
10	Breadboard	1	RM 2.70	RM 2.70
11	Relay	1	RM 3.50	RM 3.50
12	Adapter 12V 2A	1	RM 10.50	RM 10.50
13	Gabus	1	RM 10.00	RM 10.00
14	LCD 16x2	1	RM 10.60	RM 10.60
			Total: RM	RM 146.65
	List of other costing			
1	Postage			RM 10
2	Craft work			-
3	Internet			-
4	Application			-
			Total :	RM 10
			Overall Total	RM 156.65

APPENDIX C – PROGRAMMING CODING PROJECT

```
// DECLARATION LIBRARY

// library lcd

// DECLARATION PIN ARDUINO

// declaration component that you use

long duration, distance;

void setup()
{
  Serial.begin(9600);

  // NK TENTUKN INPUT / OUTPUT KOMPONEN

  // declare componen is input / output

  // DECLARE UNTUK LCD

  lcd.init();
  lcd.backlight();
}

void loop()
{
  // NK BG DPT JARAK YG TEPAT

  digitalWrite(trigPin, LOW);
  delayMicroseconds(2);
  digitalWrite(trigPin, HIGH);
  delayMicroseconds(10);
  digitalWrite(trigPin, LOW);

  // formula distance

  Serial.print(distance);
  Serial.println("cm");
```

```
// your condition, if else
```

```
}
```

```
void sms()
```

```
{
```

```
  // sending sms for letter
```

```
}
```

```
void sms1()
```

```
{
```

```
  // sending sms for parcel
```

```
}
```