



**POLITEKNIK SULTAN SALAHUDDIN ABDUL AZIZ  
SHAH**

**FIRE ALERT SYSTEM USING SMS**

NAME

REGISTRATION NO

MUHAMMAD AIMAN BIN  
SHAUDIN

08DJK20F1009

**JABATAN KEJURUTERAAN ELEKTRIK**

**SESI 1 2022/2023**

**POLITEKNIK SULTAN SALAHUDDIN ABDUL AZIZ  
SHAH**

**FIRE ALERT SYSTEM USING SMS**

<b>NAME</b>	<b>REGISTRATION NO</b>
MUHAMMAD AIMAN BIN SHAUDIN	08DJK20F1009

This report submitted to the Electrical Engineering Department in fulfillment of the requirement for a Diploma in Electrical Engineering

**JABATAN KEJURUTERAAN ELEKTRIK**

**SESI 1 2022/2023**

## **CONFIRMATION OF THE PROJECT**

The project report titled FIRE ALERT SYSTEM USING SMS has been submitted, reviewed, and verified as a fulfills the conditions and requirements of the Project

Writing as stipulated

Checked by:

Supervisor's name : ENCIK MAHMUD BIN SELAMAT

Supervisor's signature:

Date :

Verified by:

Project Coordinator name :

Signature of Coordinator :

Date :

“I acknowledge this work is my own work except the excerpts I have already explained to our source”

1. Signature :

Name : **MUHAMMAD AIMAN BIN SHAUDIN**

Registration Number : **08DJK20F1009**

Date :

**DECLARATION OF ORIGINALITY AND OWNERSHIP**

**TITLE: FIRE ALERT SYSTEM USING SMS**

**SESSION: 1 2022/2023**

1. I, **1. MUHAMMAD AIMAN BIN SHAUDIN AND NO MATRIKS  
08DJK20F1009**

is a final year student of **Diploma in Electrical Engineering,  
Department of Electrical, Politeknik Sultan Salahuddin Abdul Aziz  
Shah**, which is located at **Persiaran Usahawan, Seksyen U1, 40150  
Shah Alam, Selangor.**

2. I acknowledge that 'The Project above' and the intellectual property therein is the result of our original creation /creations without taking or impersonating any intellectual property from the other parties.
3. I agree to release the 'Project' intellectual property to 'The Polytechnics' to meet the requirements for awarding the **Diploma in Electrical Engineering** to me.

Made and in truth that is recognized by;

a) **MUHAMMAD AIMAN BIN SHAUDIN** )  
(Identification card No: - 020616100113)

.....  
) **MUHAMMAD AIMAN  
BIN SHAUDIN**

In front of me, **ENCIK MAHMUD BIN** )  
**SELAMAT** (690722015361) )  
As a project supervisor, on the date:

.....  
) **ENCIK MAHMUD BIN  
SELAMAT**

## **ACKNOWLEDGEMENTS**

I put effort on this project. However, without the kind support and assistance of many people and organizations, it would not have been feasible. I want to express my sincere gratitude to each one of them. I owe a great deal to my supervisor, Encik Mahmud bin Selamat, for his direction, continual oversight, and provision of the information required for the Project as well as for his assistance in seeing that it is finished.

I would want to thank my parents and my supervisor for their wonderful encouragement and cooperation, which helped me finish this project. I want to offer my sincere appreciation and thanks to those in the profession who took the time to pay me such close attention.

My gratitude and appreciations also go out to my coworker who helped me build the Project and those who volunteered their skills to assist me.

## **ABSTRACT**

A fire outbreak is a major tragedy that must be avoided by every possible means due to the potential loss of lives and property, fire when not controlled can grow large and may require days to bring under control. Hence this technology must be applied to minimize or even eliminate this great hazard. In This study, a fire alarm and detection system were developed. This system was built with the GSM module embedded in it, which helps to send SMS (Short messaging service) to the homeowners and the fire service personal, when there is fire outbreak before it gets out of range. Furthermore, this study provides a technology that would be accessible and affordable to the world at large so that homes, offices, and schools can adopt the use in other to protect lives and property. When the developed system is commercialized, it will help reduce uncontrolled fires by 50% because it warns of dangerous conditions before a fire outbreak.

## **ABSTRAK**

Wabak kebakaran adalah tragedi besar yang mesti dielakkan dengan segala cara yang mungkin disebabkan oleh potensi kehilangan nyawa dan harta benda, kebakaran apabila tidak dikawal boleh membesar dan mungkin memerlukan hari untuk terkawal. Oleh itu teknologi ini mestilah digunakan untuk meminimumkan atau menghapuskan kehebatan ini bahaya. Dalam kajian ini, penggera kebakaran dan pengesanan sistem dibangunkan. Sistem ini dibina dengan Modul GSM tertanam di dalamnya, yang membantu untuk menghantar SMS (Perkhidmatan pesanan ringkas) kepada pemilik rumah dan peribadi perkhidmatan bomba, apabila berlaku kebakaran wabak sebelum ia keluar dari jangkauan. Tambahan pula, kajian ini menyediakan teknologi yang akan boleh diakses dan mampu dimiliki oleh dunia secara amnya bahawa rumah, pejabat dan sekolah boleh menerima pakai penggunaan dalam lain untuk melindungi nyawa dan harta benda. Jika dan apabila sistem yang dibangunkan dikomersialkan, ia akan membantu mengurangkan kebakaran tidak terkawal sebanyak 50% kerana ia memberi amaran tentang keadaan berbahaya sebelum berlakunya kebakaran.



## TABLE OF CONTENTS

<b>CONFIRMATION OF THE PROJECT</b>	<b>i</b>
<b>DECLARATION OF ORIGINALITY AND OWNERSHIP</b>	<b>iii</b>
<b>ACKNOWLEDGEMENTS</b>	<b>iv</b>
<b>ABSTRACT</b>	<b>v</b>
<b>ABSTRAK</b>	<b>vi</b>
<b>TABLE OF CONTENTS</b>	<b>vii</b>
<b>CHAPTER 1</b>	<b>1</b>
<b>INTRODUCTION</b>	<b>1</b>
1.1 Introduction	1
1.2 Background Research	<b>Error! Bookmark not defined.</b>
1.3 Problem Statement	2
1.4 Research Objectives	2
1.5 Scope of Research	2
1.6 Project Significance	3
1.7 Chapter Summary	3
<b>CHAPTER 2</b>	<b>4</b>
<b>LITERATURE REVIEW</b>	<b>4</b>
2.1 Introduction	4
2.2 What caused the fire	5
2.2.1 Previous Research	5
2.3 Control System	6
2.3.1 Microcontroller	7
2.3.2 Programmable Logic Control (PLC)	8
2.3.3 Arduino	8
2.4 Chapter Summary	8
<b>CHAPTER 3</b>	<b>9</b>
<b>RESEARCH METHODOLOGY</b>	<b>9</b>
3.1 Introduction	9
3.2 Project Design and Overview.	9
3.2.1 Block Diagram of the Project	10
3.2.2 Flowchart of the Project 2	10
3.2.3 Project Description	12
3.3 Project Hardware	12
3.3.1 Schematic Circuit	13
3.3.2 Description of Main Component	14
3.3.2.1 Component 1	14
3.3.2.2 Component 2	15
3.3.2.3 Component 3	16
3.3.2.4 Component 4	17
3.3.2.5 Component 5	18

3.3.3	Circuit Operation	19
3.4	Project Software	19
3.4.1	Flowchart of the System	20
3.4.2	Description of Flowchart	21
3.5	Prototype Development	22
3.5.1	Mechanical Design/Product Layout	24
3.6	Sustainability Element in The Design Concept	25
3.7	Chapter Summary	25
<b>CHAPTER 4</b>		<b>27</b>
<b>RESULTS AND DISCUSSION</b>		<b>27</b>
4.1	Introduction	27
4.2	Results and Analysis	27
4.3	Discussion	31
4.4	Chapter Summary	31
<b>CHAPTER 5</b>		<b>32</b>
<b>CONCLUSION AND RECOMMENDATIONS</b>		<b>32</b>
5.1	Introduction	32
5.2	Conclusion	32
5.3	Suggestion for Future Work	32
5.4	Chapter Summary	33
<b>CHAPTER 6</b>		<b>34</b>
<b>PROJECT MANAGEMENT AND COSTING</b>		<b>34</b>
6.1	Introduction	34
6.2	Gant Chart and Activities of the Project	34
6.3	Cost and Budgeting	35
6.4	Chapter Summary	36
<b>REFERENCES</b>		<b>37</b>
<b>APPENDICES</b>		<b>38</b>
APPENDIX A-	DATA SHEET	38
APPENDIX B-	PROGRAMMING	39



# CHAPTER 1

## INTRODUCTION

### 1.1 Introduction

Fire alarm system provides an early warning of fire so that people can be evacuated, and immediate action can be taken to stop or eliminate of the fire effect as soon as possible so that properties and lives will not be at stake. My project was able to detect the heat of the fire around the sensor. My sensor will emit a sound and the host will receive an SMS about the fire in his house. It is a cost-effective fire alarm system which performs reliably to ensure safety from fire, and can be easily installed in homes, industries, offices, restaurants etc. Larger scale industrial or residential area can be monitored through the proposed system installing multiple modules, each for one floor or unit. The aim of this project is to provide a reliable and swift responsive fire alarm system using SMS.

### 1.2 Background Research

This research will investigate several elements of fire. The extent to which these items are accepted by consumers, and what issues arise, particularly those affecting design, space and functionality Are they cost effective, meet needs and function well as well as determine the extent to which the existence of these market suspensions is effective.

### **1.3 Problem Statement**

The first issue are the occupants of the house will be the first to know about the building fire by getting an SMS. The second issue are neighbors can act early to ensure the fire does not spread to other neighborhoods by the buzz noise.

### **1.4 Research Objectives**

The major goal of this project is to improve the alert system technology by introducing new capabilities.

The following are the specific goals of this research principle:

- By getting the SMS, the host will be the first to know and act in advance.
- The sound of buzz will allow neighbors to prevent the fire from spreading to adjacent homes.
- By detecting fires quickly and accurately as well as providing early warning notifications, it can save people's lives.

### **1.5 Scope of Research**

The project focuses on providing a product that is both suitable and durable for users, as well as being able to be used in regions where there is a significant risk of burns.

## **1.6 Project Significance**

This initiative is critical for a community that is frequently separated from its home. They frequently find themselves in circumstances where they have forgotten to turn off electrical appliances or hazardous gas burners. This is to ensure that horrible things don't happen.

## **1.7 Chapter Summary**

In this research in terms of introduction, objectives, problem statement, hypotheses, scope of study and limitations play an important role at the beginning of something studies to be done because this method can ensure all the products that want to be produced is according to one's needs and wants. Besides, it is be able to convince a product produced is effective and accepted on public opinion.

## **CHAPTER 2**

### **LITERATURE REVIEW**

#### **2.1 Introduction**

The authors found that most cases of fire were due to human negligence. Not only negligence, but also the attitude of not caring about the dangers of fire and how to deal with the situation is also a major factor that contributes to the occurrence of fire. In fact, firefighters themselves admit many fires occur because of excessive electrical energy consumption and negligence when operating electrical equipment.

Fires start when a flammable and/or a combustible material with an adequate supply of oxygen or another oxidizer is subjected to enough heat. For a fire to exist it requires three elements to be in place Heat, Oxygen and Fuel. The fire is prevented or extinguished by removing any one of them. A fire naturally occurs when the elements are combined in the right mixture. Without sufficient heat, a fire cannot begin, and it cannot continue. Heat can be removed by dousing with water; the water turns to steam, and the steam is further heated, taking the heat with it. Without fuel, a fire will stop. Fuel can be removed naturally, as where the fire has consumed all the burnable fuel, or manually, by mechanically or chemically removing the fuel from the fire. Without sufficient Oxygen, a fire cannot begin, and it cannot continue. With a decreased oxygen concentration, the combustion velocity gets lower.

## **2.2 What caused the fire**

Fire is the result of a chemical reaction between oxygen in the atmosphere and a type of fuel. Oxygen, fuel, and heat are needed for a fire to occur. This is known as the fire triangle. Combustion is when fuel reacts with oxygen to release heat energy.

### **2.2.1 Previous Research**

For your fire detection system to be effective, it must be integrated with a good fire alarm system. Fire alarms play a vital role in giving warnings to home residents or building occupants that there is a fire emergency. Most of these fire alarms also send out a warning signal or message to a local fire department notifying the emergency. Thus, fire alarms can Save lives. The very reason why there's a need to install a fire alarm is to make all individuals at home or inside a building safe and alive. Alarms like smoke detectors, sirens, and strobe lights can detect fire and notify all occupants, giving them enough time to evacuate. Reduce loss of property. While these alarm systems do not necessarily put out fires, they can alert people who can. Your trained family member or personnel can put out a small fire with an extinguisher while others call the local fire department. This is where the fire control process begins. Fire alarm systems also notify the responders automatically, and fire trucks can be dispatched quickly. The faster all these things are in place, the lesser the damage and loss of property. Shorten recovery time. The lesser the property's damage, the shorter the downtime until you can reopen for business. This will reduce losses from the fire and allow you to return to 'business as usual' quickly.



### 2.3 Control System

Control System theory has played an important role in the development and advancement of modern technology and civilization. Practically every aspect of our day-to-day life is affected by some type of control system.

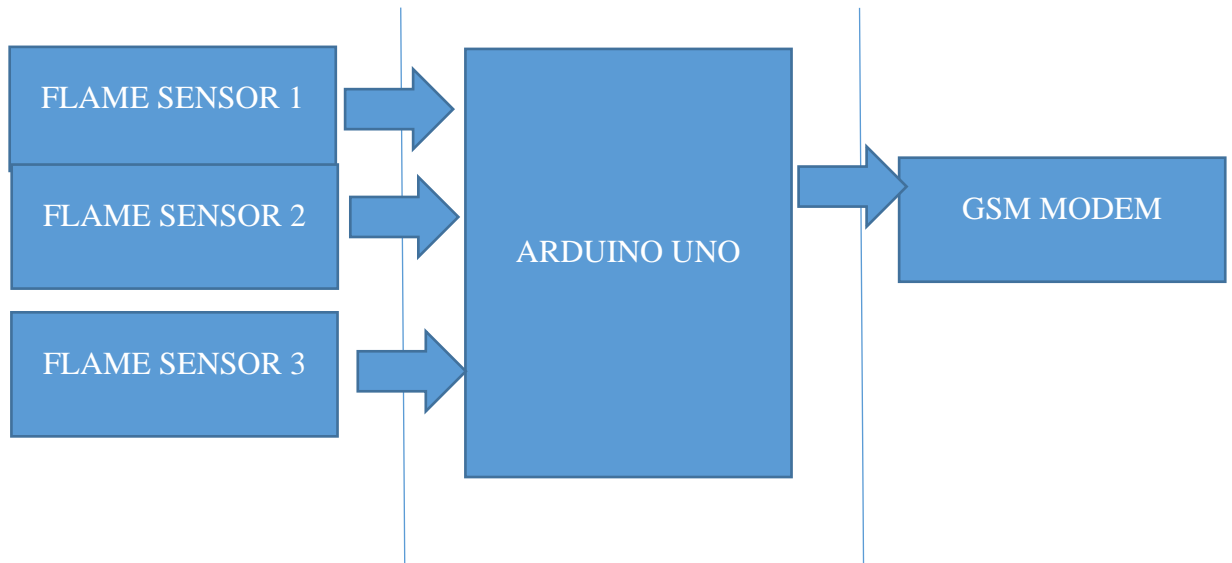

Figure 2. 1: Block diagram of open loop and closed loop system

### **2.3.1 Microcontroller**

A microcontroller is a compact integrated circuit designed to govern a specific operation in an embedded system. A typical microcontroller includes a processor, memory, and input/output (I/O) peripherals on a single chip. Sometimes referred to as an embedded controller or microcontroller unit (MCU), microcontrollers are found in vehicles, robots, office machines, medical devices, mobile radio transceivers, vending machines and home appliances, among other devices. They are essentially simple miniature personal computers (PCs) designed to control small features of a larger component, without a complex front-end operating system (OS). A microcontroller is embedded inside of a system to control a singular function in a device. It does this by interpreting data it receives from its I/O peripherals using its central processor. The temporary information that the microcontroller receives is stored in its data memory, where the processor accesses it and uses instructions stored in its program memory to decipher and apply the incoming data. It then uses its I/O peripherals to communicate and enact the appropriate action. Microcontrollers are used in a wide array of systems and devices. Devices often utilize multiple microcontrollers that work together within the device to handle their respective tasks.

### **2.3.2 Programmable Logic Control (PLC)**

A programmable logic controller (PLC), or programmable controller is an industrial digital computer control system that continuously monitors the state of input devices and makes decisions based upon a custom program to control the state of output devices. Almost any production line, machine function, or process can be greatly enhanced using this type of control system. However, the biggest benefit in using a PLC is the ability to change and replicate the operation or process while collecting and communicating vital information. Another advantage of a PLC system is that it is modular. That is, you can mix and match the types of Input and Output devices to best suit your application.

### **2.3.3 Arduino**

Arduino is an open-source hardware and software company, project, and user community that designs and manufactures single-board microcontrollers and microcontroller kits for building digital devices.

## **2.4 Chapter Summary**

Based on prior research, it can be determined that, given its function, the presence of a fire alarm system in a settlement is quite crucial. The durability parameters that must be considered for this in terms of durability are that it must be in accordance with user demand and that it may be employed in an emergency circumstance (fire). Aside from that, the factor of using the buzzer should be prioritized to ensure that the user feels safe and that there are no issues.

## **CHAPTER 3**

### **RESEARCH METHODOLOGY**

#### **3.1 Introduction**

A very detailed plan is being implemented to turn this project into a ready-to-use product with safety features. To ensure that the Project is completed on time, a step-by-step procedure is followed. Data was acquired because of previous research by other academics who used books, periodicals, papers, and the internet to conduct their research. This previous study relates to past research, and this research was carried out to augment the research in the thesis title.

#### **3.2 Project Design and Overview.**

To determine customer behavior and perceptions of these things, the surveys will be done using observational techniques. This audit will also take place in the Taman Kota housing development region in Jenjarom, Selangor. This method is utilized at random, particularly in student settlement regions, urban and rural areas, and areas with a variety of dwelling styles. Furthermore, using research methodologies, observational methods, and methods, this approach is conceptually and practically realized.

### 3.2.1 Block Diagram of the Project

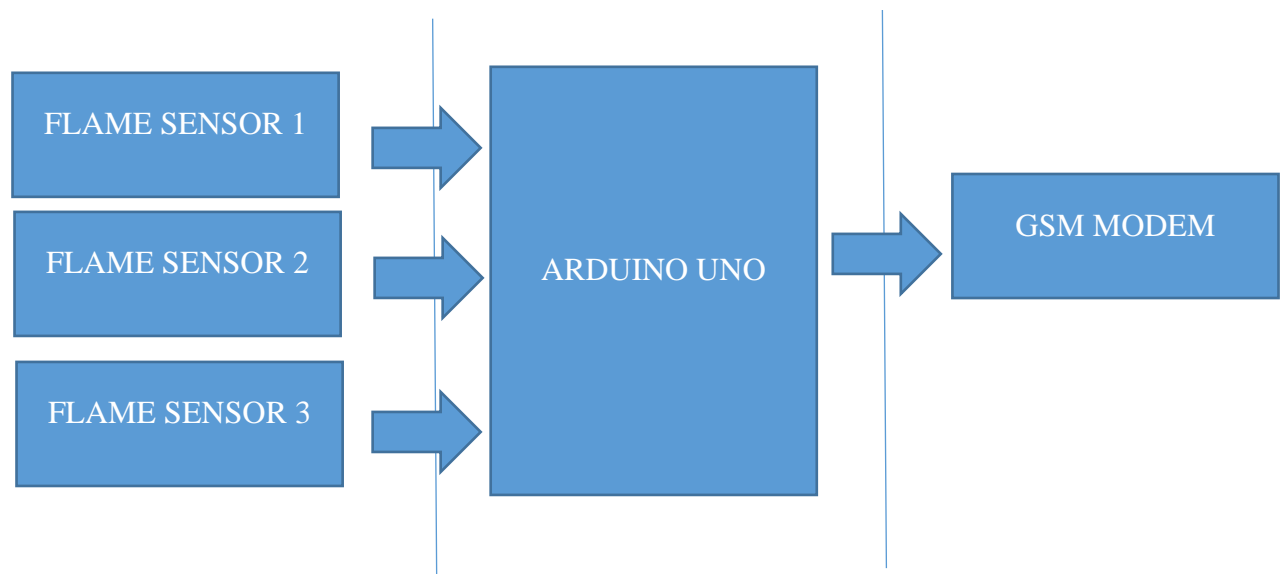

### 3.2.2 Flowchart of the Project 2

**Error! Reference source not found.** shows the circuit diagram of the whole system. It is show that the flow chart for my first project is starting, then with the normal temperature process part. Then when there is a fire, the fire sensor will be active, and the buzzer will sound, and the host will receive an SMS. So, the building can be saved earlier then my flow chart will end.

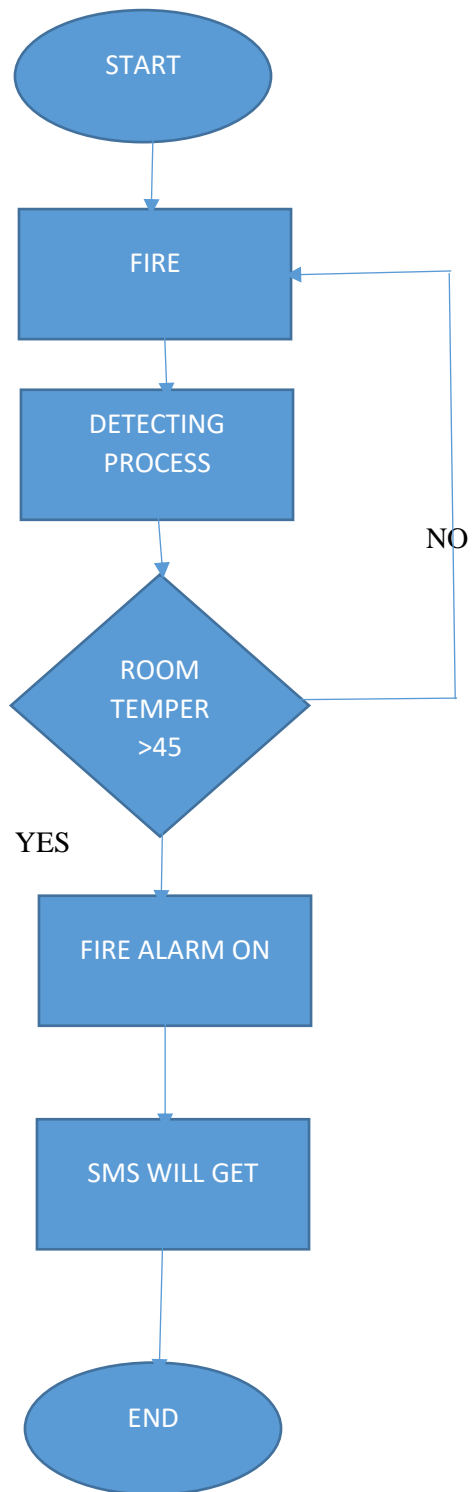

Figure 3. 1: Flow chart of operation of the system

### **3.2.3 Project Description**

The goal of this project is to create a security system that is more rigorous and capable of saving many lives. This invention is a safety sensor. When the sensor detects burning, the smartphone will receive a notification. If the building is on fire, a status will be shown on the SMS. Using this feature, many individuals may be warned if a building started to fire.

### **3.3 Project Hardware**

As mentioned in the previous chapter, a control system designed is used to help homeowners know in advance about their home in the event of a fire. First, the sensor serves as an important component because it needs to detect fire. Sensor calibration is the process of checking and adjusting the accuracy of a measuring instrument as required to ensure that measurement results are carried out and consistent with other instruments. The calibration process is carried out to test the combustion based on the room/box comparison scale temperature used to test the system.

### 3.3.1 Schematic Circuit

Figure 3. 2 shows the overall circuit diagram of this Project of fire alarm system with SMS

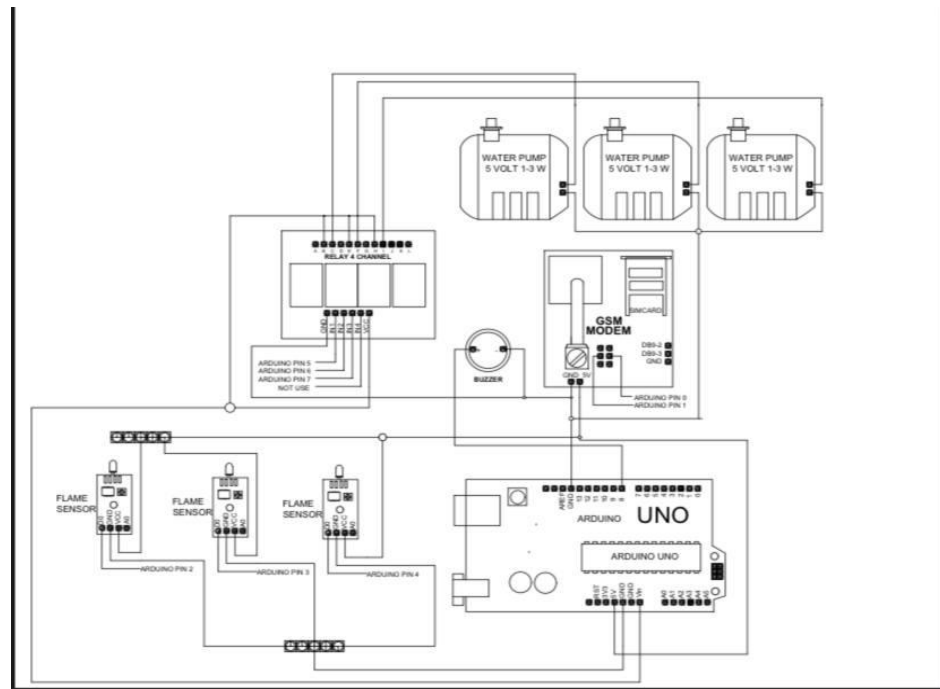

Figure 3. 2: Circuit Diagram



### 3.3.2 Description of Main Component

#### 3.3.2.1 Component 1

##### GSM MODEM



A GSM modem or GSM module is a device that uses GSM mobile telephone technology to provide a wireless data link to a network. GSM modems are used in mobile telephones and other equipment that communicates with mobile telephone networks. They use SIMs to identify their device to the network. A GSM Module is basically a GSM Modem (like SIM 900) connected to a PCB with different types of output taken from the board – say TTL Output (for Arduino, 8051 and other microcontrollers) and RS232 Output to interface directly with a PC (personal computer). The board will also have pins or provisions to attach the mic and speaker, to take out +5V or other values of power and ground connections. These types of provisions vary with different modules.

### 3.3.2.2 Component 2

#### Arduino UNO

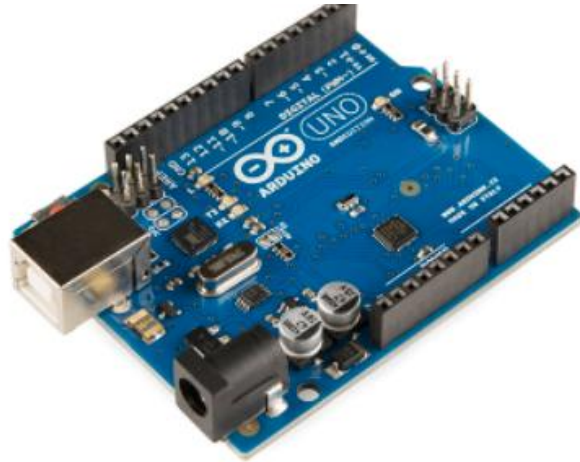

Arduino (/ɑːrˈdwiːnoʊ/) is an open-source hardware and software company, project, and user community that designs and manufactures single-board microcontrollers and microcontroller kits for building digital devices. It's hardware products are licensed under a CC BY-SA license, while software is licensed under the GNU Lesser General Public License (LGPL) or the GNU General Public License (GPL), permitting the manufacture of Arduino boards and software distribution by anyone. Arduino boards are available commercially from the official website or through authorized distributors.

Arduino board designs use a variety of microprocessors and controllers. The boards are equipped with sets of digital and analog input/output (I/O) pins that may be interfaced to various expansion boards ('shields') or breadboards (for prototyping) and other circuits. The boards feature serial communications interfaces, including Universal Serial Bus (USB) on some models, which are also used for loading programs. The microcontrollers can be programmed using the C and C++ programming languages, using a standard API which is also known as the Arduino Programming Language, inspired by the Processing language and used with a modified version of the Processing IDE. In addition to using traditional compiler toolchains, the Arduino project provides an integrated development environment (IDE) and a command line tool developed in Go. The Arduino project began in 2005 as a tool for students at the Interaction Design Institute Ivrea, Italy,<sup>[3]</sup> aiming to provide a low-cost and easy way for novices and professionals to create devices that interact with their environment using sensors and actuators. Common examples of such devices intended for beginner hobbyists include simple robots, thermostats and motion detectors. The name *Arduino* comes from a bar in Ivrea, Italy, where some of the founders of the project used to meet. The bar was named after Arduin of Ivrea, who was the margrave of the March of Ivrea and King of Italy from 1002 to 1014.

### 3.3.2.3 Component 3

#### Flame sensor



A flame detector is a type of sensor that can detect and respond to the presence of a flame. These detectors can identify smokeless liquid and smoke that can create open fire. For example, in boiler furnaces flame detectors are widely used, as a flame detector can detect heat, smoke, and fire. A flame sensor is a crucial safety component on your gas heating system. During the ignition cycle, your gas furnace goes through a process where a spark or a hot surface ignitor will ignite the gas. As the gas is ignited, the flame sensor creates a current of electricity. The electricity is calculated in micro amps. If the furnace's control board does not read the proper level of micro amps, the furnace will no longer give the system fuel to avoid an explosion. Over time, if the flame sensor is not cleaned properly, oxidation or carbon build-up can restrict the flame sensor's ability to work properly, which can result in a malfunction of the furnace. The way to establish if an unclean flame sensor is causing a furnace malfunction is to take a micro amp draw reading, which an expert heating technician can give you. If a dirty flame sensor is the guilty party, the heating expert will clean the sensor with steel wool. If dirt was the sole factor, we will see a significantly higher amp reading. If the reading shows no change, the technician will carry on with the heating system repair diagnostic process. If you aren't certain your furnace is going to outlast these last few weeks of winter, give Service Experts Heating & Air Conditioning a call and we'll come out and perform a full furnace maintenance or a no-charge in-home estimate on a new furnace.

### 3.3.2.4 Component 4

Water pump



A water pump is a small device that works with a fire pump to maintain pressure in a fire sprinkler system. It is powered by electricity, diesel, or steam, and is connected to a static water source, such as a river or water tank. The water pump provides water flow at a higher pressure to activate the sprinkler system. Building owners need to ensure that it is fully functioning to keep their occupants and property safe during an emergency. Fire pumps work by taking the water available from the water supply and increasing the pressure. This stored energy allows water to be distributed along the sprinkler lines throughout the building. Fire pumps are typically powered by electricity, steam, or combustible fuel. When the water hits the rotating impeller, energy of the impeller is transferred to the water, forcing the water out (centrifugal force). The water is displaced outward, and more water can now enter the suction side of the pump to replace the displaced water.

### 3.3.2.5 Component 4

#### Buzzer



An audio signaling device like a beeper or buzzer may be electromechanical or piezoelectric or mechanical type. The main function of this is to convert the signal from audio to sound. Generally, it is powered through DC voltage and used in timers, alarm devices, printers, alarms, computers, etc. Based on the various designs, it can generate different sounds like alarm, music, bell & siren. The **pin configuration of the buzzer** is shown below. It includes two pins namely positive and negative. The positive terminal of this is represented with the '+' symbol or a longer terminal. This terminal is powered through 6Volts whereas the negative terminal is represented with the '-' symbol or short terminal and it is connected to the GND terminal. The specifications of the buzzer include the following are Colour is black. The frequency range is 3,300Hz. Operating Temperature ranges from  $-20^{\circ}\text{C}$  to  $+60^{\circ}\text{C}$ . Operating voltage ranges from 3V to 24V DC. The sound pressure level is 85dBA or 10cm. The supply current is below 15mA. A buzzer is available in different types which include the following, which is Piezoelectric, Electromagnetic, Mechanical, Electromechanical, and Magnetic.

### **3.3.3 Circuit Operation**

Fire Alarm System with SMS Circuit is a circuit that detects the fire and activates the Buzzer. After that the owner of property will get the SMS from that. Fire Alarm Circuits are very important devices to detect fire in the right time and prevent any damage to people or property.

### **3.4 Project Software**

-Proteus software

-Arduino software

### 3.4.1 Flowchart of the System

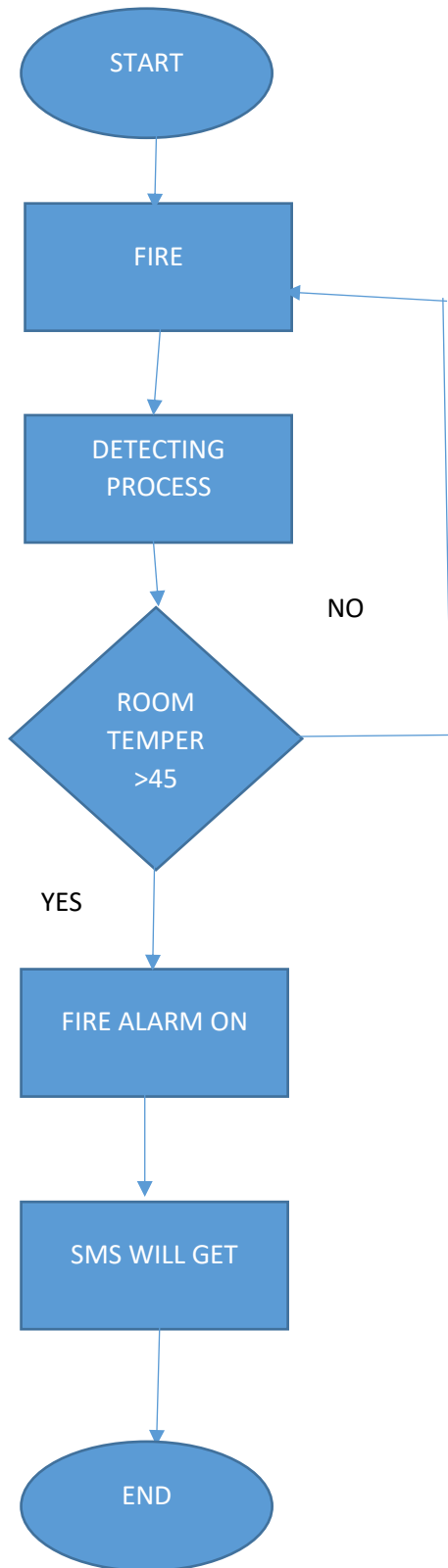

### **3.4.2 Description of Flowchart**

Start, then with the normal temperature process part. Then when there is a fire, the fire sensor will be active, and the buzzer will sound, and the host will receive an SMS. So, the building can be saved earlier then my flow chart will end.



3.5 Prototype Development





### 3.5.1 Mechanical Design/Product Layout

**Error! Reference source not found.** shows the design of the product FIRE ALERT SYSTEM USING SMS.



Figure 3. 3: Front view of the project



### **3.6 Sustainability Element in The Design Concept**

The design above shows an example of the shape I want to create. This fire alert system will be in the house. I would put it in the flammable part of the house. Buzzers will also be placed on the walls of the house for it to be heard by the public.



### **3.7 Chapter Summary**

Based on Chapter 3, I believe that offering the greatest design can assist us in completing the project with better and more effective results. My emergency system is the design I've shown. It appears to be more inventive and imaginative.



## CHAPTER 4

### RESULTS AND DISCUSSION

#### 4.1 Introduction

I was able to create a user-friendly mobile SMS fire alarm system. I tested and implemented every feature that was first requested, along with a few more. I guarantee the security of user data and requests.

#### 4.2 Results and Analysis



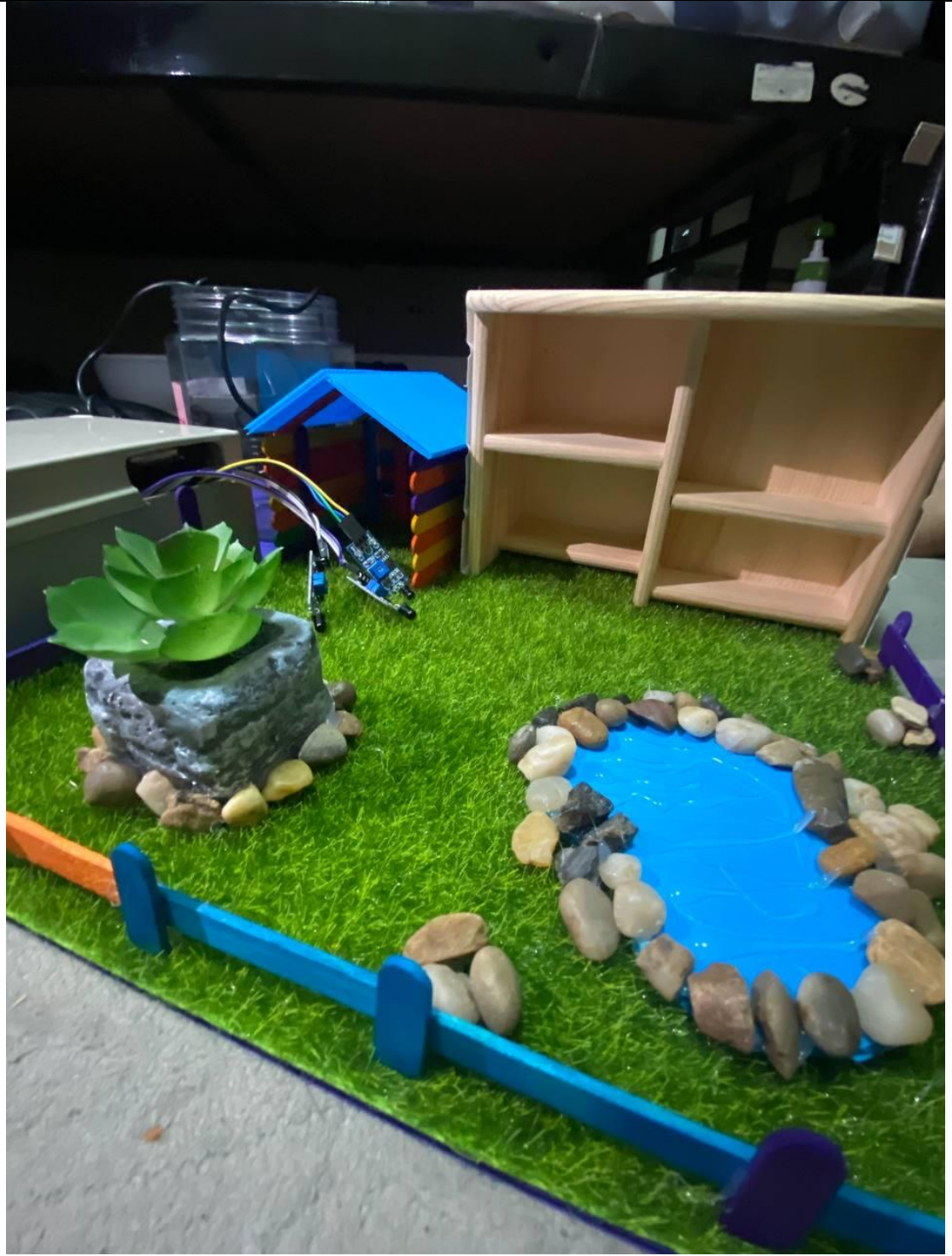

PICTURE PROJECT WITH PROTOTYPE

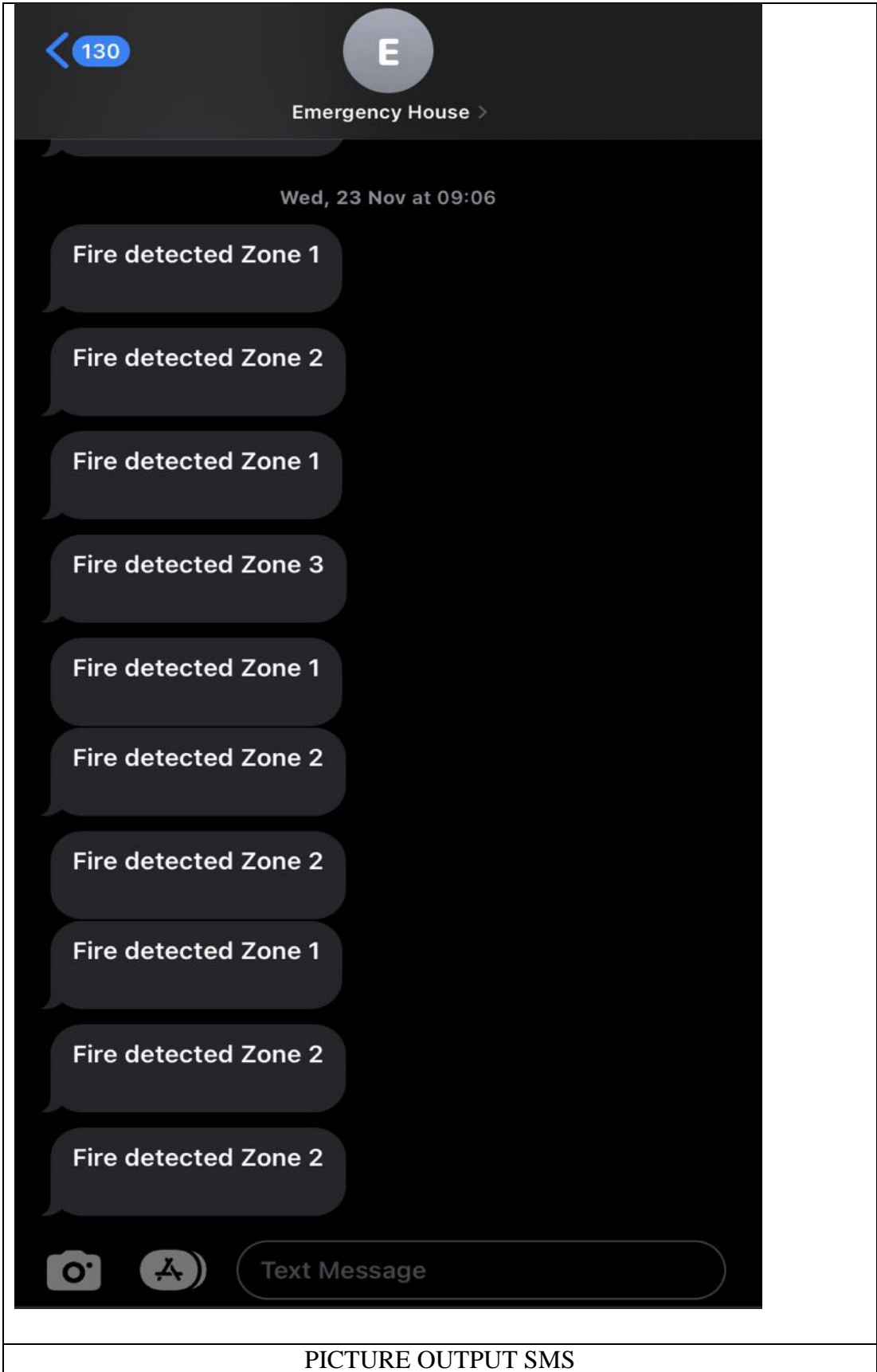

PICTURE OUTPUT SMS





**FIRE ALERT ALARM SYSTEM WITH SMS**

Nama Pelajar : MUHAMMAD AIMAN BIN SHAUDIN  
 No. Pendaftaran : 08DJK20F1009  
 Nama Penyelia : ENCIK MAHMUD BIN SELAMAT



**OBJECTIVE**

- By getting the SMS, the host will be the first to know and act in advance.
- The sound of buzz will allow neighbors to prevent the fire from spreading to adjacent homes.
- By detecting fires quickly and accurately, as well as providing early warning notifications, it can save people's lives.

**DIAGRAM PROJECT**



**ABSTRACT**

- A fire outbreak is a major tragedy that must be avoided by every possible means due to the potential loss of lives and property, fire when not controlled can grow large and may require days to bring under control.
- This system was built with the GSM module embedded in it, which helps to send SMS (Short Messaging Service) to the homeowners and the fire-service personal, when there is fire outbreak before it gets out of range.
- Furthermore, this study provides a technology that would be accessible and affordable to the world at large so that homes, offices, and schools can adopt the use in other to protect lives and property.

**ADVANTAGES**

- This can mean you may avoid major damage or even worse, the complete destruction of the home.
- A home fire alarm system gives the homeowner protection 24 hours a day, every day of the week.
- It will give the rapid response to the owner of the home and special emergency unit because it using GSM module send the alarm immediately.

**BLOCK DIAGRAM**



PICTURE AT PRESENTION PROJECT

### **4.3 Discussion**

When smoke, fire, carbon monoxide, or other fire-related or general notification emergencies are discovered, a fire alarm system alerts people. These alarms can be set off manually using fire alarm activation tools such manual call points or pull stations, as well as automatically by smoke and heat detectors. Alarms come in the form of wall-mounted sounders, horns, or mechanized bells. They can also be speaker strobes that flash an alert and then play an evacuation message warning occupants not to use the elevators. Depending on the nation and manufacturer of the device, fire alarm sounders can be adjusted to certain frequencies and different tones, including low, medium, and high. In Europe, most fire alarm systems produce an alternating siren-like sound. Horns are electronic fire alarm systems that may be set to different codes or be continuous, and they are called as such in the United States and Canada. Devices for fire alarm warnings can also be adjusted for volume.

### **4.4 Chapter Summary**

I may learn the benefits and drawbacks of utilizing SMS towards the conclusion of chapter 4 and discover the features that are relevant to my project. Additionally, when I activate the designed system, I may learn more about how the fire alert system works.

## **CHAPTER 5**

### **CONCLUSION AND RECOMMENDATIONS**

#### **5.1 Introduction**

The work completed for this report is concluded in this chapter, and some recommendations are made for my project's future.

#### **5.2 Conclusion**

In conclusion, the people approved of this initiative. Even though there were significant issues with the project at first, such as poor value and difficult use, these might eventually be fixed, and it would become widely accepted. To complete such a project and meet the requirements will take a lot of time. This project can be effectively finished with the help of the project manager's cooperation and direction. My project has met the criteria or objectives of the project because it can make it simpler and can assist owner building in monitoring the building at a distance. This is because, after numerous studies and experiments that have been done on this project, I can prove that the use successfully helped the owner of building reduce the problem of burning and has a positive impact on the public. Because it is simple to use, the system is favorably appreciated. The usefulness of this initiative is further supported by comparison with alternative approaches.

#### **5.3 Suggestion for Future Work**

I think the market's demand for enhanced security may be satisfied with the launch of this initiative. As a result, I think and hope that this project will keep growing. I therefore expect that the development of this innovation might spark more interest among those who want to build or enhance tools that can be used by everybody. This invention can lessen the load in addition to addressing our demands. This will benefit the neighborhoods as well as inspire young people to keep thinking creatively. Perhaps fresh perspectives will make this breakthrough stronger and enable it to be applied to more than just doors. The enhancement to my project that I want to make is that I want to incorporate this with the project smart house. One application makes it simple for someone to learn about the building.

## **5.4 Chapter Summary**

As a conclusion to chapter 5, I can say that I offered some changes for the fire alarm system through SMS. These suggested changes can guarantee the security of the fire alert system and ensure that there are no longer any issues. This project's objectives are to offer a straightforward technique to stop the structure from burning. I start by evaluating the need for such a system by looking at the outcomes.

# CHAPTER 6

## PROJECT MANAGEMENT AND COSTING

### 6.1 Introduction

This project involves the cost of purchasing components and materials throughout its implementation. components involving cost are Arduino uno, jumper cable, adaptor, extender, flame sensor, gsm modem and buzzer. All these components are purchased through online purchase methods to make it easier as well as save on costs.

The overall gross budget estimate in the implementation of this project around under RM 500. This budget cost, this project can be considered as a less costly project compared to other projects that can cost over a thousand ringgit. The cost of the project is also in line with one of the key features of a good project developer that is low cost but have a high-quality project.

### 6.2 Gant Chart and Activities of the Project

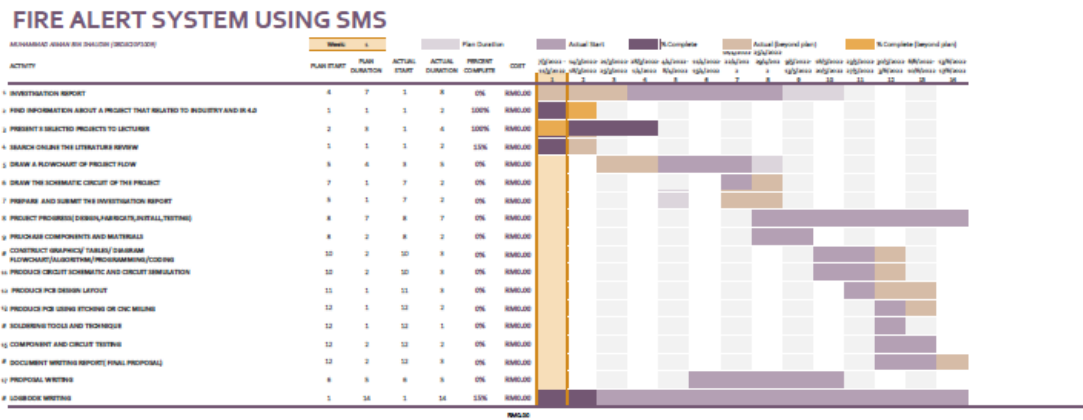

### 6.3 Cost and Budgeting

No.	Component and materials	The unit price	Quantity	Total
1	Arduino UNO	RM 36	1	RM 36
2	Jumper cable	RM 5	3	RM 15
3	Adaptor	RM 15	1	RM 15
4	Extender	RM 5	1	RM 5
5	Flame sensor	RM 10	3	RM 30
6	Gsm modem	RM 100	1	RM 100
7	Buzzer	RM 3.50	1	RM 3.50
8	Other materials		-	RM 100
			<b>Total :</b>	<b>RM 304.50</b>
	List of other costing			
1	Transportation			
2	Postage			RM 10
3	Craft Work			
4	Internet			RM 40
5	Application			
			<b>Total:</b>	<b>RM50</b>
			<b>Overall total</b>	<b>RM 354.50</b>

## **6.4 Chapter Summary**

With certain basic components and materials obtained in the project lab, the project is self-funded. It is anticipated to cost RM 1000.00 based on the cost forecast. With only RM 200 each month, the development expense can still be implemented for a period of 5 months. Based on the research completed, it is feasible and feasible.



## REFERENCES

- [1] Elbehiery, H., 2012. Developed intelligent fire alarm system. Journal of American Science Vol 8, Issue 8: 1016-1025.
- [2] Asif, O., Hossain, Md.B. Hasan, M., Rahman, M.T. and Chowdhury, M.E.H., " Fire-Detectors Review and Design of an Automated, Quick Responsive Fire-Alarm System Based on SMS." Int. J. Communications, Network and System Science, August 2014.
- [3] Rifat Husain et al. (2010) "An Intelligent Fire Detection and Mitigation System Safe from Fire" Dept. of computer science and Engineering, University of Liberal Arts Bangladesh
- [4] Zhang, L et al. (2009) "Design and implementation of Automatic Fire Alarm System Based on Wireless Sensor Networks", Proceedings of the international symposium on information processing. Microcontroller. Retrieved March 16, 2006
- [5] Suvan Kumar et al. (2015) "GSM Based Industrial Security System" Dept of Electrical Electronics Engineering. Galilea institute of technology



# APPENDICES

## APPENDIX A- POSTER



### FIRE ALERT ALARM SYSTEM WITH SMS

Nama Pelajar : MUHAMMAD AIMAN BIN SHAUDIN  
No. Pendaftaran : 08DJK20F1009  
Nama Penyelia : ENCIK MAHMUD BIN SELAMAT

#### OBJECTIVE

- By getting the SMS, the host will be the first to know and act in advance.
- The sound of buzz will allow neighbors to prevent the fire from spreading to adjacent homes.
- By detecting fires quickly and accurately as well as providing early warning notifications, it can save people's lives.

#### DIAGRAM PROJECT



#### ABSTRACT

- A fire outbreak is a major tragedy that must be avoided by every possible means due to the potential loss of lives and property, fire when not controlled can grow large and may require days to bring under control.
- This system was built with the GSM module embedded in it, which helps to send SMS (Short messaging service) to the homeowners and the fire service personal, when there is fire outbreak before it gets out of range.
- Furthermore, this study provides a technology that would be accessible and affordable to the world at large so that homes, offices, and schools can adopt the use in other to protect lives and property.

#### ADVANTAGES

- This can mean you may avoid major damage or even worse, the complete destruction of the home.
- A home fire alarm system gives the homeowner protection 24 hours a day, every day of the week.
- It Will give the rapid respond to the owner of the home and special emergency unit because it using GSM Modem send the alarm immediately

#### BLOCK DIAGRAM



```
graph LR; S1[FLAME SENSOR 1] --> A[ARDUINO UNO]; S2[FLAME SENSOR 2] --> A; S3[FLAME SENSOR 3] --> A; A --> M[GSM MODEM];
```

## APPENDIX B- PROGRAMMING

```
int hold1=0;

int hold2=0;

int hold3=0;

void setup(){

  Serial.begin(9600);

  pinMode(2, INPUT_PULLUP); // FLAME 1

  pinMode(3, INPUT_PULLUP); // FLAME 2

  pinMode(4, INPUT_PULLUP); // FLAME 3

  pinMode(5, OUTPUT); //PUMP 1

  pinMode(6, OUTPUT); //PUMP 2

  pinMode(7, OUTPUT); //PUMP 3

  pinMode(8, OUTPUT); //BUZZER

  digitalWrite(8, HIGH);

  delay(250);

  digitalWrite(8, LOW);

  delay(250);

  digitalWrite(8, HIGH);

  delay(250);

  digitalWrite(8, LOW);

  delay(250);
```

```
digitalWrite(8, HIGH);

delay(250);

digitalWrite(8, LOW);

delay(250);

}

void loop(){

int sensorVal2 = digitalRead(2);

int sensorVal3 = digitalRead(3);

int sensorVal4 = digitalRead(4);

//Serial.println(sensorVal2);

if (sensorVal2 == LOW && hold1 == 0)
{
Serial.println("A");

hold1=1;

digitalWrite(8, HIGH);

digitalWrite(5, HIGH);
```

```

Serial.println("AT+CMGF=1"); //Sets the GSM Module in Text Mode

delay(1000); // Delay of 1000 milli seconds or 1 second

Serial.println("AT+CMGS="+60173534982+"\r"); // Replace with your mobile
number

delay(1000);

Serial.println("Fire detected Zone 1");// The SMS text you want to send

delay(100);

Serial.println((char)26);// ASCII code of CTRL+Z

delay(4000);

}

else if (sensorVal3 == LOW && hold2 == 0)
{

Serial.println("B");

hold2=1;

digitalWrite(8, HIGH);

digitalWrite(6, HIGH);

Serial.println("AT+CMGF=1"); //Sets the GSM Module in Text Mode

delay(1000); // Delay of 1000 milli seconds or 1 second

Serial.println("AT+CMGS="+60173534982+"\r"); // Replace with your mobile
number

delay(1000);

Serial.println("Fire detected Zone 2");// The SMS text you want to send

```

```

delay(100);

Serial.println((char)26);// ASCII code of CTRL+Z

delay(4000);

}

else if (sensorVal4 == LOW && hold3 == 0)

{

  Serial.println("C");

  hold3=1;

  digitalWrite(7, HIGH);

  digitalWrite(8, HIGH);

  Serial.println("AT+CMGF=1"); //Sets the GSM Module in Text Mode

  delay(1000); // Delay of 1000 milli seconds or 1 second

  Serial.println("AT+CMGS="+60173534982+"\r"); // Replace with your mobile
number

  delay(1000);

  Serial.println("Fire detected Zone 3");// The SMS text you want to send

  delay(100);

  Serial.println((char)26);// ASCII code of CTRL+Z

  delay(4000);

}

else if (sensorVal2 == HIGH && sensorVal3 == HIGH && sensorVal4 == HIGH)

```

```
{  
  Serial.println("D");  
  
  hold1=0;  
  
  hold2=0;  
  
  hold3=0;  
  
  digitalWrite(8, LOW);  
  
  digitalWrite(5, LOW);  
  
  digitalWrite(6, LOW);  
  
  digitalWrite(7, LOW);  
  
}  
}
```



