

**POLITEKNIK SULTAN
SALAHUDDIN ABDUL AZIZ SHAH**

**AUTOMATIC CAT FEEDER WITH RFID
TAGS**

MUHAMMAD MUQRI BIN ROSLI

(08DJK20F1003)

JABATAN KEJURUTERAAN ELEKTRIK

SESI 1:2022/2023

**POLITEKNIK SULTAN SALAHUDDIN
ABDUL AZIZ SHAH**

AUTOMATIC CAT FEEDER WITH RFID TAG

**MUHAMMAD MUQRI BIN ROSLI
(08DJK20F1003)**

**This report was submitted to the Department of Electrical
Engineering as partial fulfillment of the award conditions**

Diploma of Electrical Engineering

JABATAN KEJURUTERAAN ELEKTRIK

SESI 1:2022/2023

CONFIRMATION OF THE PROJECT

The project report titled "AUTOMATIC CAT FEEDER WITH RFID TAG" has been submitted, reviewed and verified as it fulfills the conditions and requirements of the Project Writing as stipulated

Checked by:

Supervisor's name :PUAN NORDIANA BINTI MOHD NOR

Supervisor's signature:

Date :

Verified by:

Project Coordinator name :

Signature of Coordinator :

Date :

“I acknowledge this work is my own work except the excerpts I have already explained to our source”

1. Signature : 

Name : **MUHAMMAD MUQRI BIN ROSLI**

Registration Number : **08DJK20F1003**

Date :

DECLARATION OF ORIGINALITY AND OWNERSHIP

AUTOMATIC CAT FEEDER WITH RFID TAG

1. Me, MUHAMMAD MUORI BIN ROSLI (NO KP: 020527-03-0213) is a student Diploma Kejuruteraan Elektrik, Politeknik Sultan Salahuddin Abdul Aziz Shah, which is addressed at Persiaran Usahawan, Politeknik Sultan Salahuddin Abdul Aziz Shah, 40150 Shah Alam, Selangor.
(Hereafter referred to as 'the Polytechnic').
2. I acknowledge that the 'Above Project' and the intellectual property in it are the result of my original work/design without taking or copying any intellectual property from other parties..
3. I agree to allow ownership of the intellectual property of 'the Project' to 'the Polytechnic' to meet the requirements to obtain the award Diploma Kejuruteraan Elektrik to me.

Made and it truth recognized by;

MUHAMMAD MUQRI BIN ROSLI

(Identification Card: 020527-03-0213)

)

) MUHAMMAD MUQRI
BIN ROSLI

In front of me,

PUAN NORDIANA BINTI MOHD NOR

(Identification Card;)

As a project supervisor on the date:)

.....

PUAN NORDIANA
BINTI MOHD NOR

:

ACKNOWLEDGEMENTS

I have taken efforts in this project. However, it would not have been possible without the kind support and help of many individuals and organizations. I would like to extend my sincere thanks to all of them. I am highly indebted to PUAN NORDIANA BINTI MOHD NOR for their guidance and constant supervision as well as for providing necessary information regarding the project & also for their support in completing the project.

I would like to express my gratitude towards my parents & member of POLITEKNIK SULTAN SALAHUDDIN ABDUL AZIZ SHAH for their kind co-operation and encouragement which help me in completion of this project. I would like to express my special gratitude and thanks to industry persons for giving me such attention and time.

My thanks and appreciations also go to my colleague in developing the project and people who have willingly helped me out with their abilities.

ABSTRACT

Most of us have pets at home, some have the patience to feed them regularly, but some don't. So, taking care of them during our busy schedule is one of the main problems in maintaining pets. We even must worry about them when we leave our home for some days. I have come up with an idea called "Automatic Cat Feeder With Rfid".

It is a device that feeds cat food only on certain pet keys, for example a pet cat that attaches a rfid tag to its neck only. Because this project can only be accessed on programmed rfid tags. all the timings are programmed in the microcontroller program. this project is equipped with the use of a dc geared motor that functions as a cat food producer in the tank provided. Led lights are used as a warning when the cat food is at a low level. Arduino is also a process for this project because of everything Entered Program Requires Control from Arduino by Entering the Desired Program

ABSTRAK

Kebanyakan daripada kita mempunyai haiwan peliharaan di rumah, ada yang sabar untuk memberi mereka makan dengan kerap, tetapi ada yang tidak. Jadi, menjaga mereka semasa jadual sibuk kita adalah salah satu masalah utama dalam menjaga haiwan peliharaan. Kita juga mesti bimbang tentang mereka apabila kita meninggalkan rumah kita untuk beberapa hari. Saya telah menghasilkan idea yang dipanggil "Penyumpahan Kucing Automatik Dengan RFID".

Ia adalah peranti yang menyuap makanan kucing hanya pada kunci haiwan peliharaan tertentu, contohnya kucing peliharaan yang melekatkan tag rfid pada lehernya sahaja. Kerana projek ini hanya boleh diakses pada tag rfid yang diprogramkan. semua pemasaan diprogramkan dalam program mikropengawal. projek ini dilengkapi dengan penggunaan dc geared motor yang berfungsi sebagai pengeluar makanan kucing dalam tangki yang disediakan. Lampu LED digunakan sebagai amaran apabila makanan kucing berada pada tahap rendah. Arduino juga merupakan proses untuk projek ini kerana segala-galanya Program yang Dimasukkan Memerlukan Kawalan daripada Arduino dengan Memasuki Program yang Diingini

TABLE OF CONTENTS

CHAPTER	CONTENT	PAGE
	CONFIRMATION OF THE PROJECT	i
	DECLARATION OF ORIGINALITY AND OWNERSHIP	iii
	ACKNOWLEDGEMNETS	iv
	ABSTRACT	v
	ABSTRAK	iv
	TABLE OF CONTENTS	vii
	LIST OF TABLES	x
	LIST OF FIGURES	xi
	LIST OF SYMBOLS	xii
	LIST OF ABBREVIATION	xiii
	CHAPTER 1	
1	INTRODUCTION	
	1.1 Introduction	1
	1.2 Background Research	1
	1.3 Problem Statement	2
	1.4 Research Objectives	2
	1.5 Scope of Research	2
	1.6 Project Significance	2
	1.7 Chapter Summary	3
	CHAPTER 2	
2	LITERATURE REVIEW	
	2.1 Introduction	4
	2.2 Previous Research	4
	2.3Control system	11
	2.4Chapter Summary	12

3	CHAPTER 3	
	RESEARCH METHODOLOGY	
	3.1 Introduction	13
	3.2 Project Design and Overview	13
	3.3 Project Hardware	15
	3.4 Project Software	18
	3.5 Prototype Development	19
	3.6 Sustainability elements in the design	21
	3.7 Chapter summary	21
4	CHAPTER 4	
	RESULT AND DISCUSSION	
	4.1 Introduction	23
	4.2 Result and Analysis	23
	4.3 Discussion	24
	4.4 Chapter Summary	24
5	CHAPTER 5	
	CONCLUSION AND SUGGESTION	
	5.1 Introduction	25
	5.2 Conclusion	25
	5.3 Suggestions for future work	25
	5.4 Chapter Summary	26
6	CHAPTER 6	
	CONCLUSION AND SUGGESTION	
	6.1 Introduction	27
	6.2 Ghant Chart and Activities of project	28
	6.3 Milestone	29
	6.2 Cost and budgeting	30
	6.3 Chapter Summary	31
	REFERENCES	22
	APPENDICES	23

LIST OF TABLE

NO. TABLE	TITLE	PAGE
2.1	Comparison Of Cat Feeder	10
4.1	Result	30

LIST OF FIGURE

NO. FIGURE	TITLE	PAGE
2.1	Block Diagram Of open loop and close loop.	11
3.1	Flowchart of operation system	14
3.2	Circuit Diagram	15
3.3	Circuit Operation	18
3.4	Flowchart System	19
3.5	Prototype	20
3.6	Mechanical Design	21
4.1	Result	23
6.1	Ghant Chart	28
6.2	Milestone	29

LIST OF SYMBOLS

Simbol

f	Frekuensi
m	Jisim
P	Tekanan
r	Jejari

LIST OF ABBREVIATIONS

CeTRI
Innovation

Centre for Telecommunication Research and

CHAPTER 1

INTRODUCTION

1.1 INTRODUCTION

Nowadays most of us have pets at home. these pets should be well cared for. Their mealtimes are important because they have become part of the family. however, some people fail to pay attention to their pets because they are too busy to be able to feed them on time. This paper addresses the above problem by introducing Smart Pet Eaters to ensure your pets are fed on time. This Automatic Cat Feeder with Rfid Tags consists of food storage, servo motor, dispenser, dining bowl and more. It also has an Arduino to control the operation automatically, as well as possible to create more high technology by adding cameras to monitor the activities of their pets.

Automatic Cat Feeder with Rfid Tags has an automatic generating machine that can feed your pet in a specified quantity and can only produce food when the animal uses a specific RFID tag only. Using this machine, pet owners do not have to be with their pet all the time to prepare food. They can also do other work outside without taking care of pets. Pet dishes are filled in one container by setting the time and date using an Arduino Uno that has been displayed on an Lcd mounted on the pet mediator

1.2 BACKGROUND RESEARCH

In the present generation, almost all people want to keep a pet in their home as they believe that a pet in house can decrease daily stress, boredom and loneliness from daily life. But in a developing nation citizen has a very high-level activity that causes negligence to take care of pet regarding food and water supply in equal interval of time. They are engaged to various activities and get little time to monitor pet at house. To supply food to pet with adjustable quantity at predefined time has been an essential task in present scenario. Automated cat feeder can replace manual cat feeding method into a modern one. There are some cat feeders proposed with connectivity to the internet and hence monitoring is possible from remote location. The author proposed some additional features that can be added to convert the cat feeder into automatic cat feeder with RFID tag keeping the cost of realization within acceptable range for the consumer so that the demand of automated pet feeding systems may be made high. Smart cat feeder and Programmable cat feeder are two of those research that have been found about automatic pet feeder. From a survey by veterinary doctor, it is revealed 60% of cats are suffering from obesity. Lack of exercise and overeating are the main reasons for the pet obesity. Sometimes pet owner pours excessive amount of food to the bowl in frequent interval of time may affect pet's health. Hence controlled amount of food supply is essential for pet health. Attention paid to our proposed prototype to maintain some unique features such as the budget for realization, efficiency, compactness, assigning time and quantity of food release. To prevent the feeding problem, we introduce the automatic cat feeder with rfid tag a prototype that has been proposed for the same shall have high demand in the market for taking care of pet in the house. The proposed prototype has been designed to supply food to pet through preprogramed instruction assigned by the owner

1.3 PROBLEM STATEMENT

Being busy with your daily routine contributes to a less organized life. Therefore, people will forget about other things like taking care of pets. Animal nutrition and health should be taken care of so that they will not be a problem in the future. In addition, keeping people busy with their work so that they do not have time to take care of them can leave our pets in a bad and hungry mood. In this case, all the problems mentioned can be solved with the idea of creating this machine. It works automatically and is an easy-to-use method for all ages. It works perfectly at home and on the go. Concepts and mechanical controls via electronic systems are easy to use to improve the functionality of these devices as efficiently as possible. The set of specifications is tailored to the needs of the user or animal. Nutrition time, food quantity, and the latest engineering features are being used to create smooth functioning. In conclusion this reason can solve the problem of pet feeding

1.4 RESEARCH OBJECTIVE

The main objective of this Project is to create a product that can automatically remove pet food for animal that have rfid tag .More specifically the principle objective of this research are to design the cat feeder by using engineering software which is solid works.Next,to make cat feeders using conventional machines and engineering tool Arduino Uno

1.5 SCOPE OF RESEARCH

This Project is focusing to design a system for cat feeder with rfid tag. The emphasis is to make a cat feeder with RFID tag ,the product only produce the cat food to cat who has a tag so it can cats keepers no longer have to worry about cats scrambling for food with other cats.The main controller is using Rfid Sensor Arduino relay and Dc Geared Motor.

1.6 PROJECT SIGNIFICANT

Although the smart pet feeder currently used in Malaysia could perform well and consumers are willing to pay a high price for it. However, some pet lovers could not afford to buy a pet feeder worth RM1000 + and moreover it requires high shipping costs due to its expensive price and high quality. Therefore, the findings of this study will bring many benefits to animal lovers who cannot afford expensive pet feeder. In addition, it will also make it easier for consumers to feed their pets during their absence at home. Moreover, it really benefits the consumers as they no longer have to worry about their pets and will never let their pets go hungry again.

1.7 CHAPTER SUMMARY

In this chapter, studies have been explained about the origins of ideas and inspiration. All objectives are made up of all problem statements. The objective of this project and its importance will be to be a cheap and easy -to -use cat feeder to make it easier for users and even the scope of this project is only focused on animals that have RFID tags to eat their food. Therefore, this smart pet feeder can be used for daily routine with excellent care for a longer lifespan.

CHAPTER 2

LITERATURE REVIEW

2.1 INTRODUCTION

This chapter is provided description of literature review done regards to the project title of design and fabrication for cat feeder. The literature review started with the other product of cat feeder that is widely used. There are several products that are common in the production of cat feeder. With the explanation of each product, the advantages and disadvantages can be seen in those products and can help to make upgrade for another better product

2.2 AUTOMATIC CAT FEEDER (Literature Review Topic 1)

NO	TITLE/AUTHOR	OBJECTIVE	METHOD	RESULT
1	Whiskers Feeder Robot By: Andrew Walen	An automatic cat feeder is a must-have for anyone looking to keep their cats fed while they're away, whether during the day or during short vacations. They are also useful for doling out precise portions to cats on specific diets, or for automating morning feedings so your cats stop waking up you and instead start waiting by the feeder for breakfast.	The design of the Feeder-Robot is simultaneously futuristic and friendly, though it's definitely on the larger side, so buyers should be ready for it to take up a fair amount of space.	The Whisker Feeder-Robot had a variety of intuitive feeding options and the most useful app of any feeder tested. The feeder scored especially high marks for its features, effectiveness, timer accuracy, and portion control.



NO	TITLE/AUTHOR	OBJECTIVE	METHOD	RESULT
2	Wo Pet Automatic Pet Feeder By: Caitlin McCornack and Ashley Keegan	The objective of project is The feeder has infrared sensors that stop the dispenser if there's already food in the bowl. This helps keep your cat's food fresh and prevents food from spilling or getting backed up.	This feeder does it all. It controls the portion size of each feeding (which can be scheduled up to four times a day), lets you leave a voice-recorded message for your pet letting them know it's time to eat, and looks good while doing it.	The design of this Wo Pet dispenser is different from most. Its sleek white exterior won't clash with your decor, and its narrow shape will fit anywhere. And don't worry about power outages while you're away: This dispenser has a battery backup system, although batteries aren't included.



NO	TITLE/AUTHOR	OBJECTIVE	METHOD	RESULT
3.	Gravity-Based Automatic Cat Feeder By: Mallory Crusta	The objective of this project is to Build The simplest of automatic feeders, these units dispense food using nothing but the power of gravity.	The Product is not timed, they're not adjustable, and you can't use them to watch your cat from around the world, but for some, they're a convenient solution	These feeders work well for people who want to manage their cat's dry food intake according to a controlled schedule. Quality varies widely and you might find yourself with a feeder that jams or dispenses imprecisely . If you need to closely control your cat's food intake.

NO	TITLE/AUTHOR	OBJECTIVE	METHOD	RESULT
4	<p data-bbox="427 360 639 465">Pet Safe 5 meal Automatic Cat Feeder</p> <p data-bbox="427 506 679 539">By: Kaitlyn Wells</p>	<p data-bbox="719 360 983 831">The objective of the project which is for humans to operate, and one of the hardest for pets to break into. It's accurate, because it relies on you to portion the meals in advance rather than using an automated scoop or dispensing system.</p>	<p data-bbox="1023 360 1182 1827">The tray cover stores kibble in each segment, and a cutout lets your pet eat the food in the uncovered segment at their leisure. When the timer goes off, the tray rotates clockwise to reveal a new segment.(Although it has only five trays, you can program up to nine timers, which is useful if your pet needs to eat more frequently and you're available to refill it twice a day.)</p>	<p data-bbox="1209 360 1378 1536">the PetSafe 5-Meal feeder doesn't run on a power adapter; it needs four D-cell batteries. While it's nice knowing this plate feeder will work even if your power goes out, you're still stuck reprogramming the machine when the batteries eventually die, and it has no low-battery indicator to warn you before that happens.</p>

NO	TITLE/AUTHOR	OBJECTIVE	METHOD	RESULT
5	<p>Well To Be Automatic Pet Food Dispenser With Two-Way Splitter</p> <p>By: Mr Gadget</p>	<p>Feeds two pets at the same time. Sensor prevent over filling the bowl. Has a warning light to alert you that the device needs to be refilled.</p>	<p>The features an infrared sensor that monitors how much food is in a bowl, eventually signaling the device to stop dispensing if the bowl is full. Aside from that, there's a blue light that turns on once the amount of food in the storage is low, signaling you to refill soon. Just like the previous entries on this list, you can record your voice for up to 10 seconds and have the machine play it back whenever it dispenses food.</p>	<p>The two way splitter is a simple yet effective way of feeding two pet. It has battery power backup power supply. it comes with two stainless steel bowls</p>

2.2.1 PREVIOUS RESEARCH (Subtopic Literature Review Topic 1)

Diagram	Characteristic	Problems	References
<p data-bbox="312 443 467 510">Automatic Pet Feeder</p> 	<ul style="list-style-type: none"> - Remote Controlling and Large LCD Control Panel, convenient for setting and programming - Dual power supply system (battery mode and rechargeable mode) with low power warning. -Flexible and Convenient Dispensing: Supporting feeding 1-5 meals per day, selecting 1-12 portions for each meal. 	<ul style="list-style-type: none"> -Use the remote -Can't use with the mobile app -Only use for one pet 	<p>Shopee.com.my</p>
<p data-bbox="312 1176 467 1283">Alice Automatic Feeder</p> 	<ul style="list-style-type: none"> -Suitable for small cats and dogs -Brand IRIS/ALICE -Non-toxic material -Safety use -Premium quality 	<ul style="list-style-type: none"> -Use manually -Cheap -Only use for one pet 	<p>Lazada.com.my</p>

<p>Pawple Automatic PetFeeder</p> 	<p>-Worry free pet 'butler'</p> <ul style="list-style-type: none"> -Customized convenience -User-friendly LCD display -Dishwasher-safe durability -Digital timer 	<ul style="list-style-type: none"> -No mobile Application -No WIFI connection 	<p>Amazom.com</p>
<p>Rollipet Smart Pet Feeder</p> 	<ul style="list-style-type: none"> -can operate it from anywhere using smart phone, - it has a battery backup and has a camera 	<ul style="list-style-type: none"> -The WIFI periodically resetting in the middle of the night -Not accessible for a long time -Only use for one pet only 	<p>Amazom.com</p>

The Table Show Comparison Of Cat Feeder

2.3 CONTROL SYSTEM (Literature Review Topic 2)

Control System theory has played an important role in a set of mechanical or electronic devices that regulates other devices or systems by way of control loops. Typically, control systems are computerized. Control systems are a central part of industry and of automation.

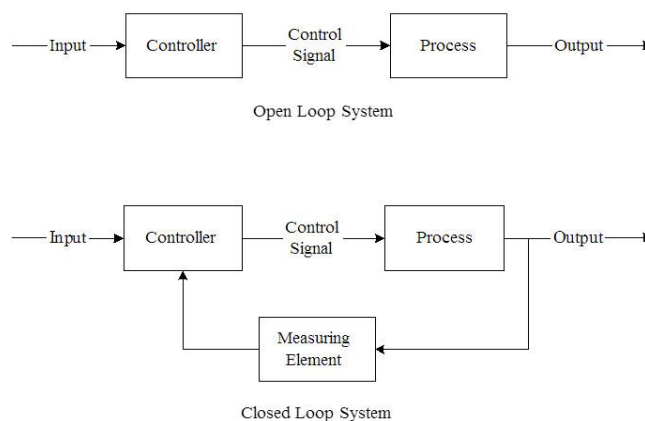

Figure 2. 1: Block diagram of open loop and closed loop system

2.3.1 MICROCONTROLLER

A microcontroller is an integrated circuit that contains a microprocessor along with memory and associated circuits and that controls some or all of the functions of an electronic device (such as a home appliance) or system.

2.3.2 PROGRAMMABLE LOGIC CONTROL(PLC)

A programmable logic controller (PLC), or programmable controller is an industrial digital computer is a type of tiny computer that can receive data through its inputs and send operating instructions through its outputs.

2.3.3 ARDUINO

Arduino Uno electronic board, it functions to create programs to control various electronic components. And this Arduino Uno function is made to make it easier for users to do prototyping, program microcontrollers, make advanced tools based on microcontrollers

2.4 CHAPTER SUMMARY

This section focusing on two different section, the first is some information from the control system, microcontroller, Programmable Logic Control (PLC), and Arduino identifies its function. The second section is discovered about the technical part, including the selection of the type of controller.

CHAPTER 3

RESEARCH METHODOLOGY

3.1 INTRODUCTION

To realize this Project as a ready to use product with security features, a very comprehensive plan is being implemented. A step by step procedure is done so that the Project can be completed within the stipulated time. This includes collecting mechanical part design data, circuit design testing and validation.

3.2 PROJECT DESIGN AND OVERVIEW

As mentioned in the previous chapter, the controller is designed using a closed loop system with the Arduino as the main controller. The design of the controller circuit using Arduino is realized using Proteus Software and then converted to PCB circuit. In proteus arduino processes the input provided by the rfid sensor and the output is used such Led.

3.2.1 BLOCK DIAGRAM OF THE PROJECT

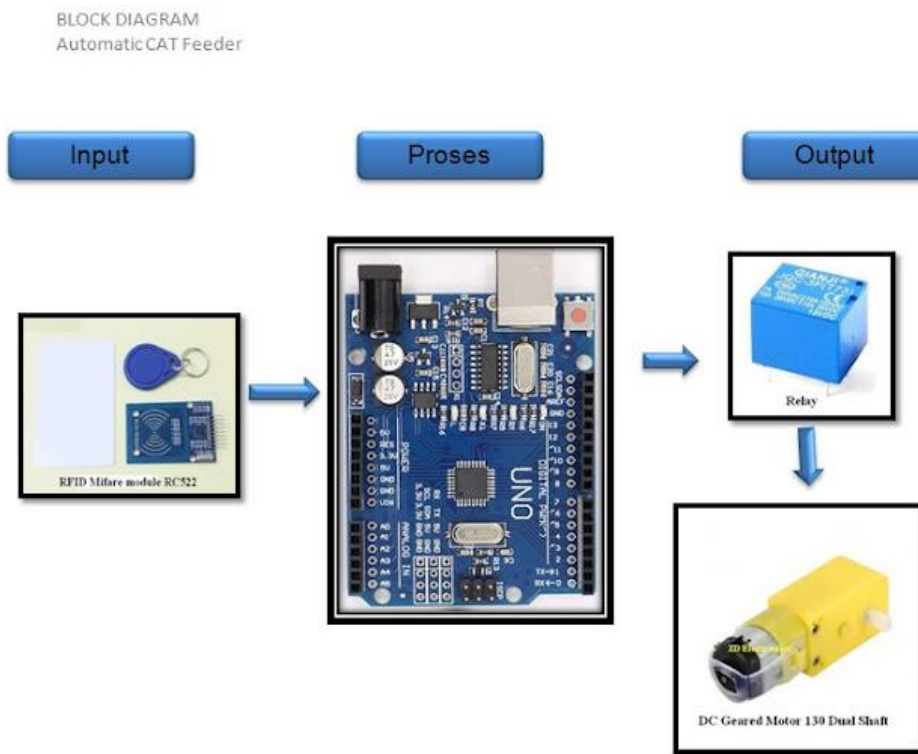

The Figure Show Block Diagram Of Project

3.2.2 FLOWCHART OF THE PROJECT 2

Figure 3. 1 shows the circuit diagram of the whole system. It is show that rfid sensor if detected rfid tag will proceed to Arduino .If no ,it will not proceed .Next Arduino process will proceed to relay and dc geared motor..

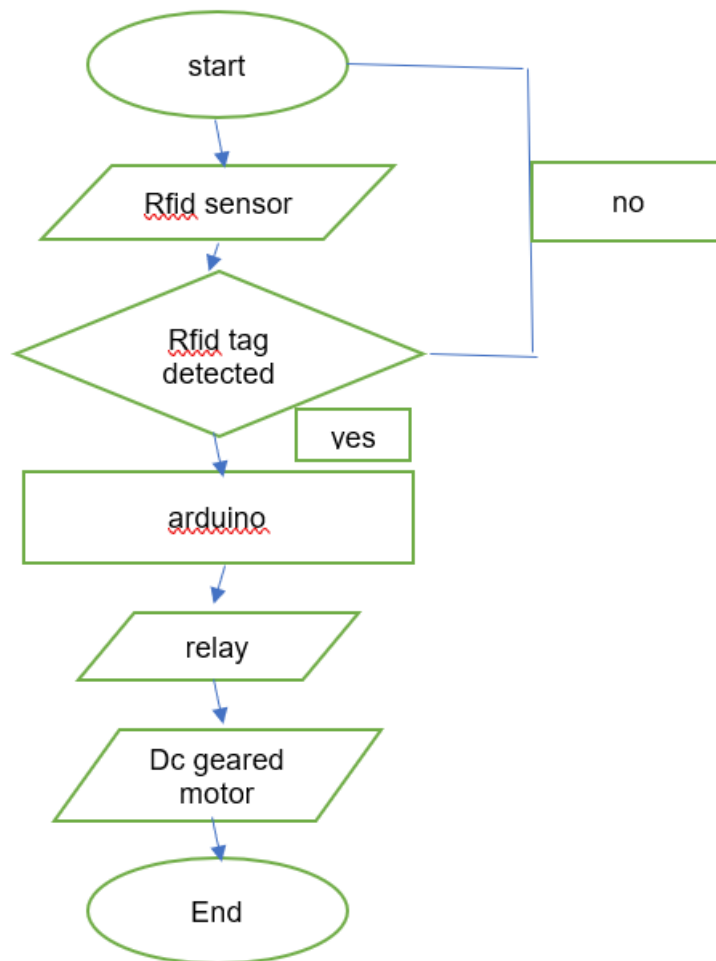

Figure 3. 1: Flow chart of operation of the system

*Images may be subject to copyright

3.2.3 PROJECT DESCRIPTION

This project works in a way that when a cat that has been wearing an rfid tag on its neck comes into contact with the rfid sensor, the dc geared motor will release food that has been timed for three seconds. If the food is reduced, the LED can warn with a lit LED light.

3.3 PROJECT HARDWARE

As mention in previous chapter, the design controller is using Arduino as a process of this project. Then, the dc geared motor will remove cat food when a cat wearing an RFID tag comes into contact with the RFID sensor found on Project

3.3.1 SCHEMATIC CIRCUIT

Figure 3. 2 shows the overall circuit diagram of this Project Automatic Cat Feeder With Rfid Tag.

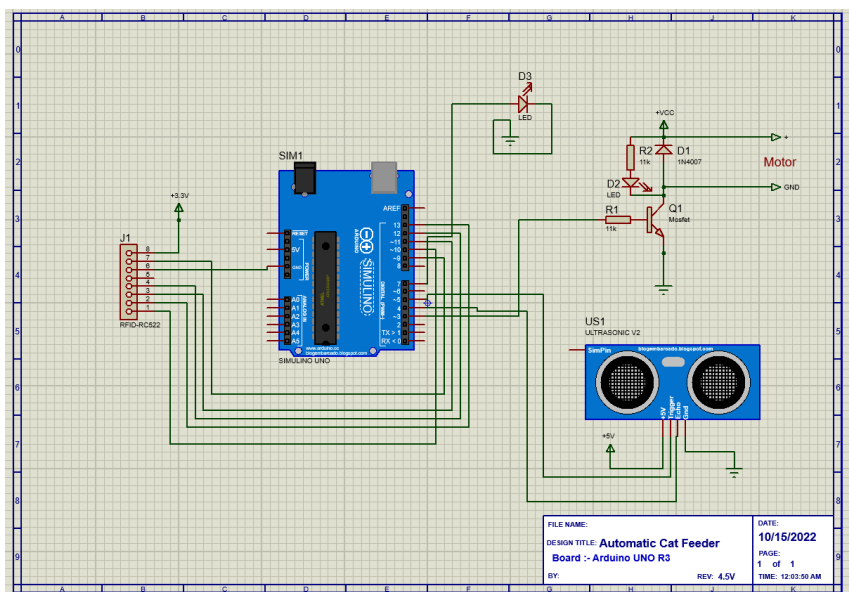

Figure 3. 2: Circuit Diagram
*Images may be subject to copyright

3.3.2 DESCRIPTION OF MAIN COMPONENT

3.3.2.1 COMPONENT 1



RFID SENSOR

Device That Can Detect The Rfid Tag whose coding has been programmed into the arduino uno

3.3.2.2 COMPONENT 2



Arduino

Arduino is an open-source microcontroller board based on the Microchip ATmega328P microcontroller and developed by Arduino.cc.

3.3.2.3 COMPONENT 3



Dc Geared Motor

works to move the actuator placed in the cat food tank to be able to remove the cat food

3.3.3 CIRCUIT OPERATION

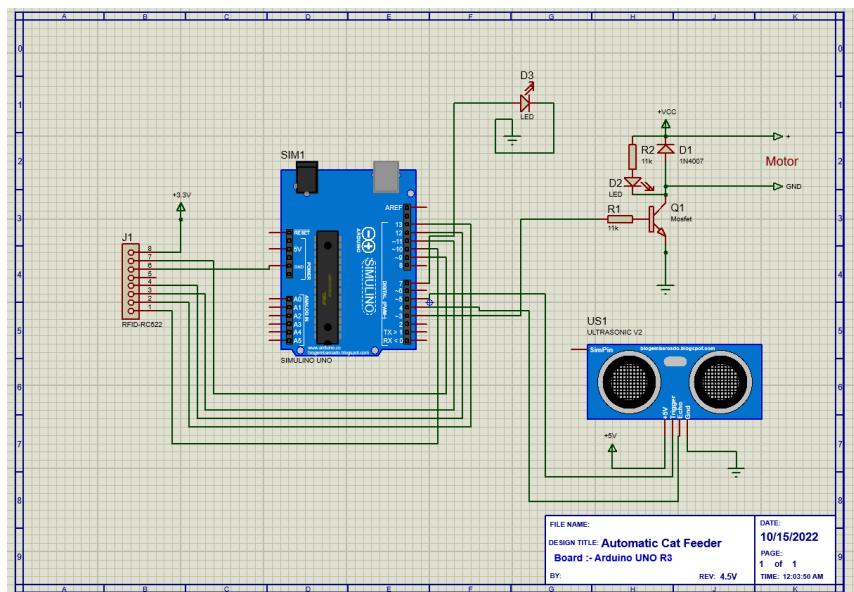

Figure 3.3: Circuit Operation

3.4 PROJECT SOFTWARE

The Project Software used to Successful This Project is proteus 8 professional , software Arduino uno 1.8.9 and design the project using thinkercad

3.4.1 FLOWCHART OF THE SYSTEM

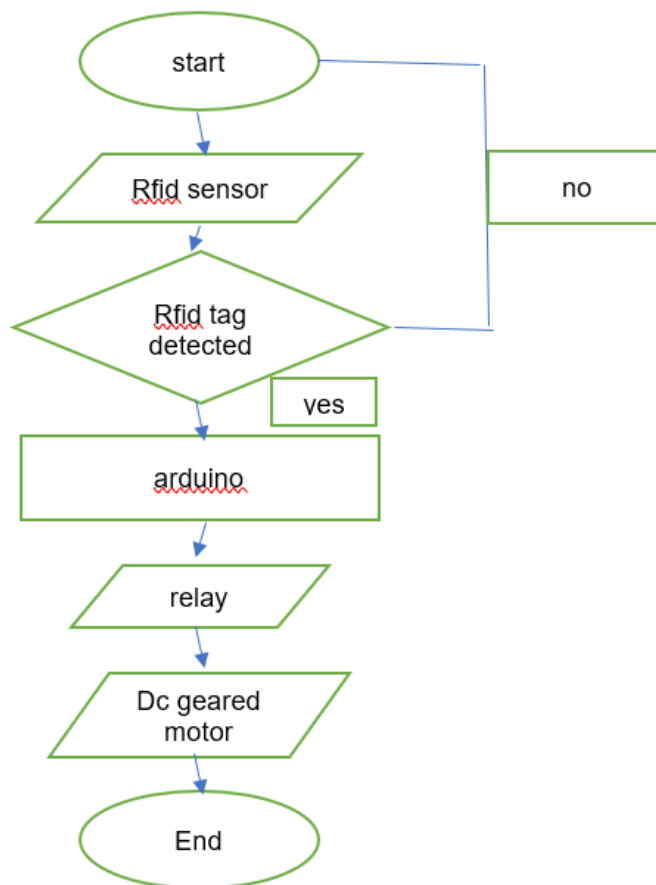

Figure 3.4:Flowchart system

3.4.2 DESCRIPTION OF FLOWCHART

The flowchart is show that rfid sensor if detected rfid tag will proceed to Arduino.If no,it will not proceed next Arduino process will proceed to relay , dc geared motor

3.5 PROTOTYPE DEVELOPMENT

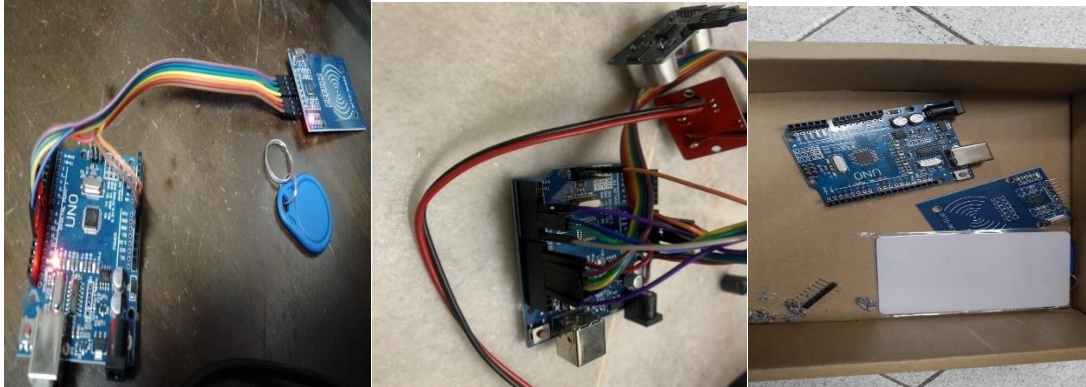

Figure 3.5: Prototype development

3.5.1 MECHANICAL DESIGN/PRODUCT LAYOUT

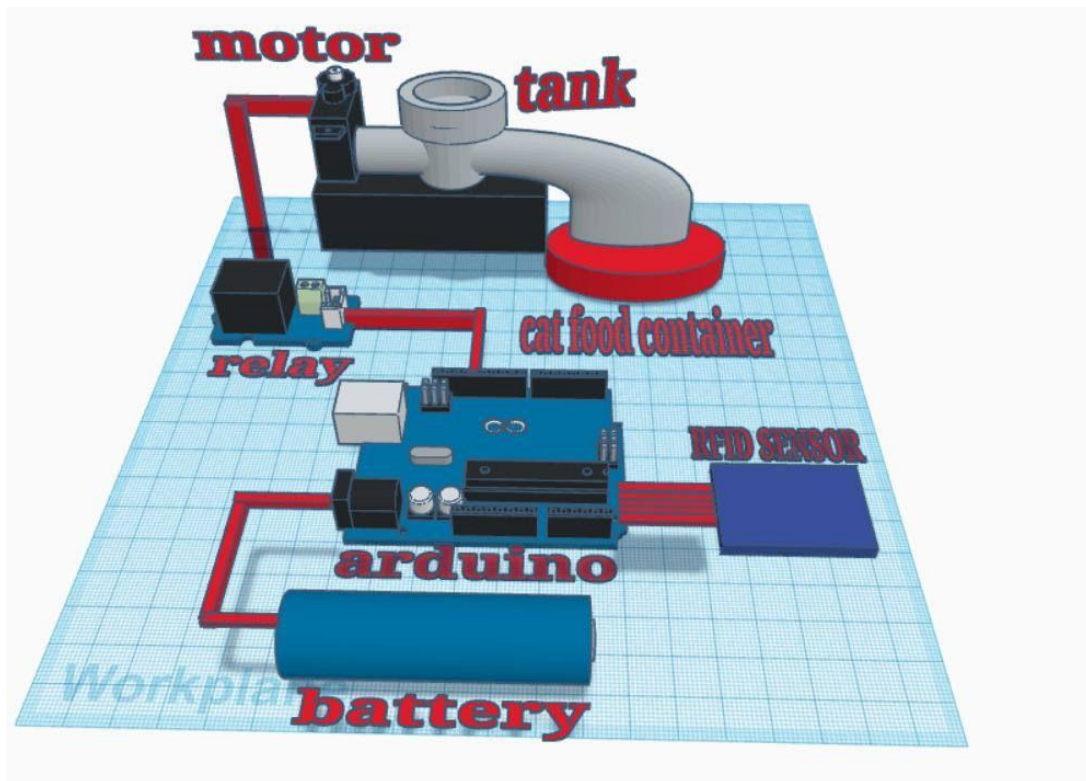

Figure 3. 3: Design Of Product

3.6 SUSTAINIBLY ELEMENT IN THE DESIGN CONCEPT

In this project, Rfid Sensor has been applied, that is, able to detect rfid tags that have been programmed . when the rfid tag can be detected it will send information to the arduino causing the relay to work to ensure that the dc geared motor can move and can turn the movement in the cat food tank and can remove the cat food.

3.7 CHAPTER SUMMARY

In this chapter, the study design, data collection methods, research instruments, data sampling techniques and data analysis methods are made systematically in the methodological study to know the facts and information to support the research instrument and describe more clearly in this study. After the data analysis is done, it is important to make a conclusion or conclusion on the results and hypotheses that is whether the trap is effective or not.

CHAPTER 4

RESULTS AND DISCUSSION

4.1 INTRODUCTION

Regarding the research that has been done, it can help us to know about our project in more detail for each component and function so that this project can work according to the purpose that we have wanted.

4.2 RESULT AND ANALYSIS

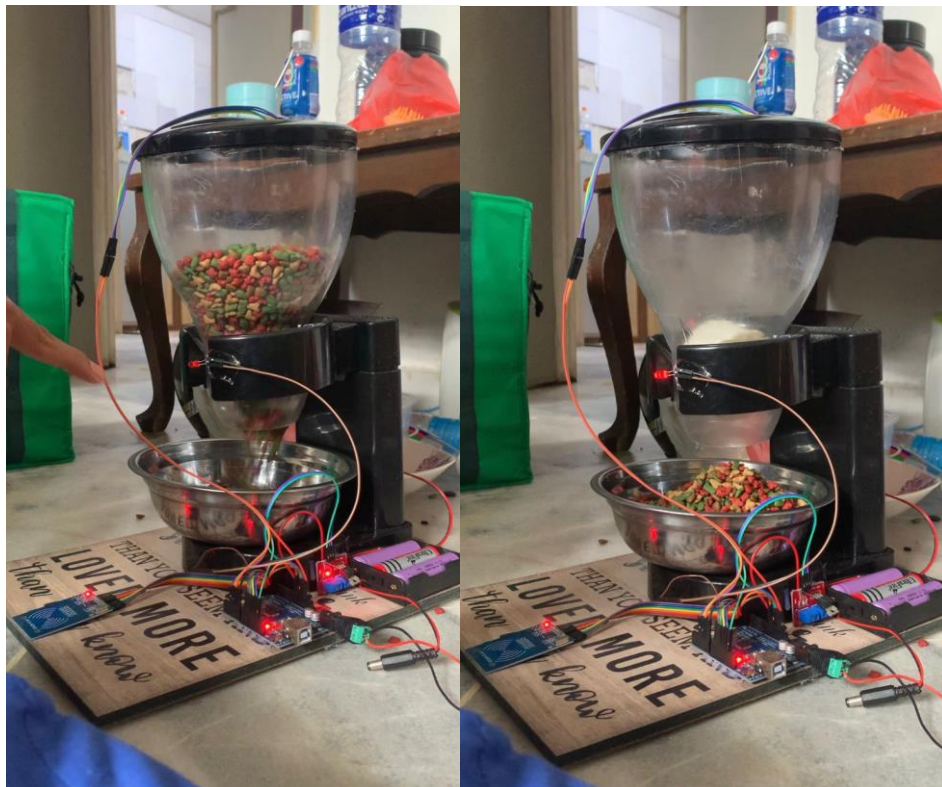

FIGURE 4.1.RESULT

4.3 DISCUSSION

In planning an activity and work related to the project carried out, Discussions with the supervisor to reach the best consensus has been made to ensure that the activities run smoothly as planned and arranged. Each week there will be a meeting with the project supervisor to discuss the latest developments related to the report as well as the progress of the planned project. In addition, all problems encountered such as project shortcomings, problems to obtain information related to the project and so on are also voiced to get the best views and solutions from the views of our supervisors. All planning is done carefully. With this, the issues and developments of this project can be shared. All doubts and problems related to the project are discussed at this time until a solution is reached by mutual agreement.

4.4 CHAPTER SUMMARY

As a conclusion to this chapter, analysis and findings have been made. This project has many advantages but there are every bad to good. Therefore, challenges are taken as room for improvement and more development for the next generation and also to increase their knowledge about the projects we are running. Run tests are conducted to determine the full potential and proven to satisfy users

CHAPTER 5

CONCLUSION AND RECOMMENDATIONS

5.1 INTRODUCTION

Follow up at the end of the project until it is completed and successfully made tests, studies, get results such as data analysis and so on. Here it gives a lot of new knowledge lessons about each project information in detail and is beneficial during the project making process.

5.2 CONCLUSION

This project brings together several components and ideas to achieve the common goal of designing an automatic cat feeder with rfid tag using Arduino UNO. The main component of the project includes dc geared motor which will be programmed to serve the food as soon as the pet comes. It relieves the owner from having to feed his pet multiple times a day. The proposed project senses the presence of the pet using rfid tag . The owner does not have to worry about making plans or feeding his pet because of this smart pet feeder. This automatic pet feeder serves as a helping hand as it works efficiently in the absence of the own. Through This Project it helps to develop creativity in crating projects and modify existing projects to be more energy efficient with new fabrication methods. This smart pet feeder innovation makes it easy for consumers to feed their pets and will not leave their pets hungry again.

5.3 SUGGESTION FOR FUTURE WORK

My suggestion for future work for this project is that this project can also be used for humans, for example it can be marketed for hotels, as a cereal dispenser that can only be taken by the hotel's occupants. By way of rfid tags given to hotel occupants who make payments with food package at the hotel. I'm sure this project can be widely marketed because it can not only be used for cats it can also be used for human consumption

5.4 CHAPTER SUMMARY

In this chapter, it focuses on the conclusions that I got at the end of this project in terms of every aspect that has been done successfully. In addition, in the end this project can bring benefits to the users who use it.

CHAPTER 6

PROJECT MANAGEMENT AND COSTING

6.1 INTRODUCTION

In this chapter, I have done some planning and management for this project, such as planning activities to do this project so that it runs smoothly and have also noted the costs that have been incurred to make this project a success.

6.2 Gant Chart and Activities of the Project

AUTOMATIC CAT FEEDER WITH RFID TAG

MUHAMMAD MUQRI BIN ROSLI (08DJK20F1003)

Week: 1 Plan Duration

ACTIVITY	PLAN START	PLAN DURATION	ACTUAL START	ACTUAL DURATION	PERCENT COMPLETE	COST
1 INSTALLATION	1	10	1	8	25%	RM100
2 INSTALLATION OF COMPONENTS ON PCB	1	1	1	2	100%	RM25
3 INSTALLATION OF WIRING	1	3	1	4	35%	RM25
4 INSTALLATION OF SOFTWARE	1	1	1	2	10%	RM50
5 INSTALLATION OF CONTROL CIRCUIT / SYSTEM	3	4	3	5	85%	RM0
6 INSTALLATION OF PROJECT CASING	7	1	7	2	85%	RM50
7 TESTING	7	1	7	2	50%	RM0
8 TEST THE ELECTRONIC PART	8	7	8	7	60%	RM0
9 TEST THE MECHANICAL PART	8	2	8	2	75%	RM0
10 TEST THE OVERALL PROCESS / PROJECT	10	2	10	3	100%	RM0
11 DOCUMENTS	10	2	10	3	60%	RM0
11 PREPARATION OF SLIDE PRESENTATION	11	1	11	2	0%	RM0
12 PREPARATION OF LOGBOOK	12	1	12	1	50%	RM0
13 PREPARATION OF PROJECT 2 FINAL REPORT	12	1	12	2	0%	RM0
14 PREPARATION OF INSTRUCTION MANUAL	12	2	12	3	1%	RM0
						RM250

6.4 Cost and Budgeting

No.	Component and materials	The unit price	Quantity	Total
1	Arduino UNO r3set	RM 70.00	1	RM 50.00
2	20ways male to female jumper wire	RM 15	1	RM 15
3	20wasys male to male jumper wires	RM 15	1	RM 15
4	20 ways female to female jumper wire	RM 15	1	RM 15
5	RFID MODULE TAG	RM 10	1	RM 10
6	CARD	RM 10	1	RM 10
7	ADAPTOR 12V 2AMP	RM20	1	RM 20
8	MAKANAN KUCING	RM10	2	RM 10
9	Other materials	RM 100	-	RM 50
	Total:			RM 195
	List of other costing			
1	Transportation			10
2	Postage			20
3	internet			15
4	Application			10
	Total:			
			Overall total	RM 250

6.5 Chapter Summary

This section is show the Program schedule project manufacturing travel process, First is the project milestones and then the project cost calculated the project manufacturing and cost for the other list.

REFERENCES

Andrew Whalen- Updated on 04/13/22

-Andrew is a commerce editor for Treehugger and The Spruce Pet. His writing has appeared on Popular Science, Inverse, Newsweek, and Vice

-Caitlin McCormack and Ashley Keegan on February 18, 2022

-Mallory Crusta

-Kaitlyn Wells November 11, 2021

-MR GADGET 1 APRIL 2022

-<https://closerpets.com/blogs/news/top-5-benefits-of-automatic-pet-feeders>

APPENDICES

APPENDIX A- DATA SHEET

[BP Projek Pelajar Diploma Politeknik 2021 Final 11Mac-converted.docx](#)

APPENDIX B- PROGRAMMING

```
#include <Wire.h>

#include <SPI.h>

#include <MFRC522.h>

#define SS_PIN 10

#define RST_PIN 9

#define LED_G A1 // Green LED pin

#define LED_R A2 // Red LED pin

#define motor 3

// Define sensor pins #####

#define trigger 5

#define echo 4

float time=0,distance=0;

#define buzzer 7

MFRC522 mfrc522(SS_PIN, RST_PIN);

int SW_manual = 8;
```

```
void setup()
{
  Serial.begin(9600);
  SPI.begin();
  mfrc522.PCD_Init();

  pinMode(trigger,OUTPUT);
  pinMode(echo,INPUT);

  //pinMode(LED_G, OUTPUT);
  // pinMode(LED_R, OUTPUT);
  pinMode(SW_manual,INPUT_PULLUP);
  pinMode(motor,OUTPUT);
  pinMode(buzzer, OUTPUT);

  Serial.println("Ready on card on reader...");
  Serial.println();

}

void loop()
{

  digitalWrite(trigger,LOW);
```



```
delayMicroseconds(2);  
digitalWrite(trigger,HIGH);  
delayMicroseconds(10);  
digitalWrite(trigger,LOW);  
delayMicroseconds(2);  
time=pulseIn(echo,HIGH);  
distance=time*340/20000;  
Serial.println(distance);  
delay(100);  
  
if( distance > 10 )  
  
{  
  
digitalWrite(buzzer, HIGH);  
  
}  
  
else if( distance < 10 )  
  
{  
  
digitalWrite(buzzer, LOW);
```

```
}
```

```
if(digitalRead(SW_manual) == LOW){
```

```
    Serial.println("Makanan sedia diberi motor ON");
```

```
    Serial.println();
```

```
    delay(500);
```

```
    // digitalWrite(LED_G, HIGH);
```

```
    digitalWrite(motor,HIGH);
```

```
    delay(3000);           //untuk masa makan
```

```
    digitalWrite(motor,LOW);
```

```
    delay(100);
```

```
    Serial.println("Motor OFF");
```

```
    // digitalWrite(LED_G, LOW);
```

```
}
```

```
// Look for new cards
```

```
if ( ! mfrc522.PICC_IsNewCardPresent())
```

```
{
```

```
    return;
```

```
}
```

```

// Select one of the cards

if ( ! mfrc522.PICC_ReadCardSerial()

{

    return;

}

//Show UID on serial monitor

Serial.print("UID tag :");

String content= "";

byte letter;

for (byte i = 0; i < mfrc522.uid.size; i++)

{

    Serial.print(mfrc522.uid.uidByte[i] < 0x10 ? " 0" : " ");

    Serial.print(mfrc522.uid.uidByte[i], HEX);

    content.concat(String(mfrc522.uid.uidByte[i] < 0x10 ? " 0" : " "));

    content.concat(String(mfrc522.uid.uidByte[i], HEX));

}

Serial.println();

Serial.print("Message : ");

content.toUpperCase();

if (content.substring(1) == "D1 76 D9 24") //change here the UID of
card/cards or tag/tags that you want to give access

```

```

{
    Serial.println("Makanan sedia diberi motor ON");

    Serial.println();

    delay(500);

    // digitalWrite(LED_G, HIGH);

    digitalWrite(motor,HIGH);

    delay(3000);

    digitalWrite(motor,LOW);

    delay(100);

    Serial.println("Motor OFF");

    // digitalWrite(LED_G, LOW);

}

else

{

    Serial.println("Card tidak sah");

    /* digitalWrite(LED_R, HIGH);

    digitalWrite(LED_R, LOW);

    delay(100);

    digitalWrite(LED_R, HIGH);

    delay(500);

```

```
digitalWrite(LED_R, LOW);  
  
delay(100);  
  
digitalWrite(LED_R, HIGH);  
  
delay(500);  
  
digitalWrite(LED_R, LOW);*/  
  
}  
  
delay (100);  
  
}
```

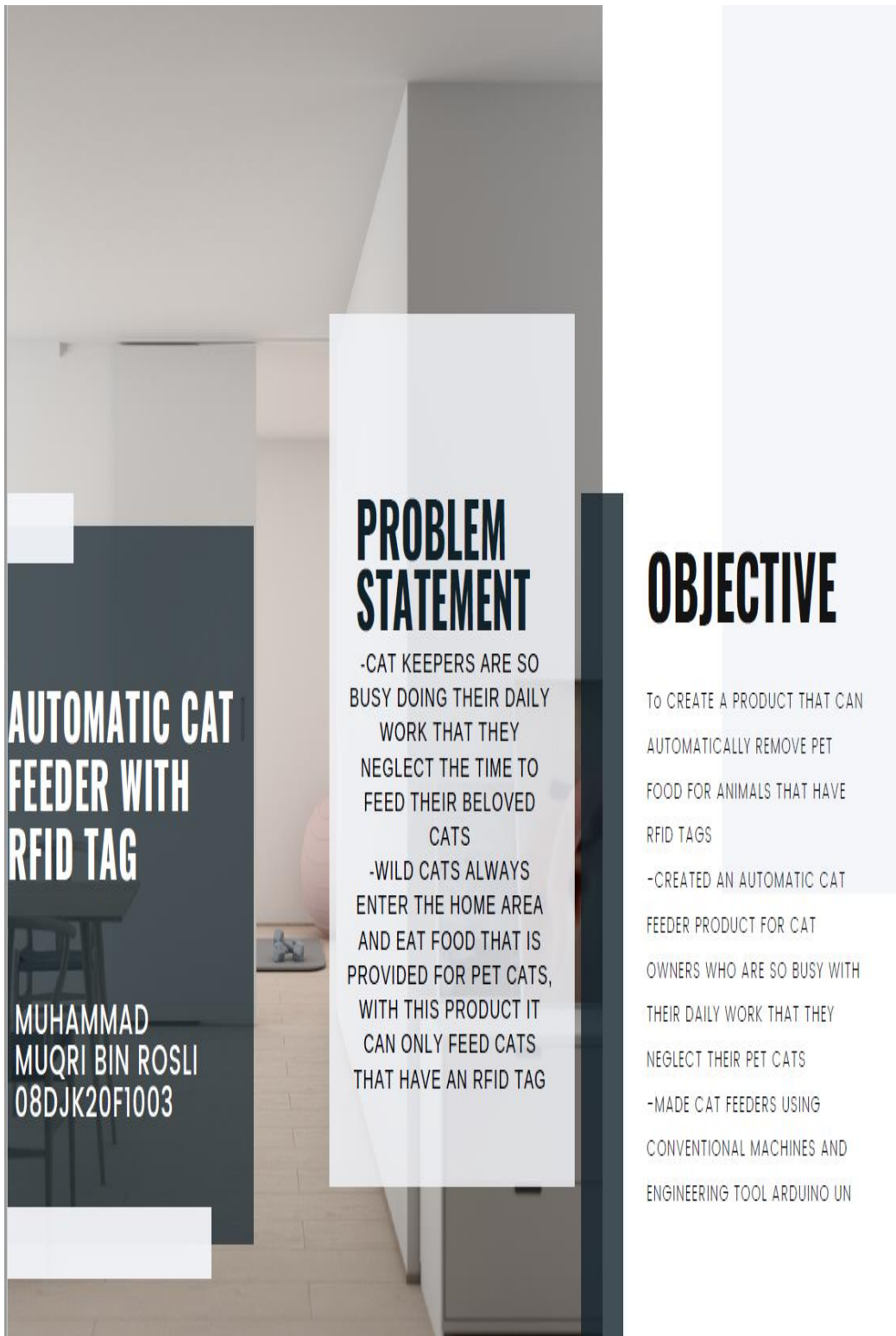

AUTOMATIC CAT FEEDER WITH RFID TAG

MUHAMMAD MUQRI BIN ROSLI
08DJK20F1003

PROBLEM STATEMENT

- CAT KEEPERS ARE SO BUSY DOING THEIR DAILY WORK THAT THEY NEGLECT THE TIME TO FEED THEIR BELOVED CATS
- WILD CATS ALWAYS ENTER THE HOME AREA AND EAT FOOD THAT IS PROVIDED FOR PET CATS, WITH THIS PRODUCT IT CAN ONLY FEED CATS THAT HAVE AN RFID TAG

OBJECTIVE

- To CREATE A PRODUCT THAT CAN AUTOMATICALLY REMOVE PET FOOD FOR ANIMALS THAT HAVE RFID TAGS
- CREATED AN AUTOMATIC CAT FEEDER PRODUCT FOR CAT OWNERS WHO ARE SO BUSY WITH THEIR DAILY WORK THAT THEY NEGLECT THEIR PET CATS
- MADE CAT FEEDERS USING CONVENTIONAL MACHINES AND ENGINEERING TOOL ARDUINO UN

INNOVATION IMPACT

THIS PROJECT CAN BE WIDELY MARKETED TO THE MARKET BECAUSE THE MARKET FOR CAT FEEDERS IS NOW MORE FOCUSED ON MANUAL CAT FEEDERS WITH ITS PROJECT THIS AUTOMATIC CAT FEEDER WITH RFID PROJECT MAY BE THE FIRST CAT FEEDER PRODUCT WITH RFID TAG IN THE MARKET. BY MARKETING THIS PROJECT MAY BE IS IN HIGH DEMAND IN THE MARKET



BLOCK DIAGRAM



THE AUTOMATIC CAT FEEDER WITH RFID TAG PROJECT IS A PROJECT TO FEED CATS AUTOMATICALLY. IN THIS PROJECT, RFID TAGS ARE USED TO SELECT ONLY CATS THAT HAVE A TAG TO REMOVE FOOD FROM THE CONTAINER. IF A CAT THAT DOES NOT HAVE A TAG COMES NEAR THE FOOD CONTAINER, THE FOOD WILL NOT COME OUT. THIS WAY CAN SAVE FOOD AND PROVIDE FOOD COMFORT TO THE USER'S FAVORITE CAT. THIS PROJECT ALSO REMOVES THE WORRY FOR USERS IF THEY RETURN TO THE VILLAGE, WORRY IF THERE IS NOT ENOUGH FOOD FOR THEIR FAVORITE CAT.

