

SULIT



**BAHAGIAN PEPERIKSAAN DAN PENILAIAN
JABATAN PENDIDIKAN POLITEKNIK DAN KOLEJ KOMUNITI
KEMENTERIAN PENGAJIAN TINGGI**

JABATAN KEJURUTERAAN MEKANIKAL

PENILAIAN ALTERNATIF

SESI 1 : 2021/2022

DJJ30093: ENGINEERING MECHANICS

**NAMA PENYELARAS KURSUS : TENGKU MOHD AIZAN BIN TENGKU
MOHAMMAD**

KAEDAH PENILAIAN : PEPERIKSAAN ATAS TALIAN

JENIS PENILAIAN : SOALAN ESEI BERSTRUKTUR (2 SOALAN)

TARIKH PENILAIAN : 3 FEBRUARI 2022

TEMPOH PENILAIAN : 2 JAM

LARANGAN TERHADAP PLAGIARISM (AKTA 174)

**PELAJAR TIDAK BOLEH MEMPLAGIAT APA-APA IDEA, PENULISAN, DATA
ATAU CIPTAAN ORANG LAIN. PLAGIAT ADALAH SALAH SATU
PENYELEWENGAN AKADEMIK. SEKIRANYA PELAJAR DIBUKTIKAN
MELAKUKAN PLAGIARISM, PENILAIAN BAGI KURSUS BERKENAAN AKAN
DIMANSUHKAN DAN DIBERI GRED F DENGAN NILAI MATA 0.**

**(RUJUK BUKU ARAHAN-ARAHAN PEPERIKSAAN DAN KAEDAH PENILAIAN (Diploma) EDISI 6, JUN 2019,
KLAUSA 17.3)**

INSTRUCTION:

This section consists of **TWO (2)** structured essay questions. Answer **ALL** questions.

ARAHAN:

Bahagian ini mengandungi DUA (2) soalan esei berstruktur. Jawab SEMUA soalan.

QUESTION 1**SOALAN 1**

CLO1
C2

(a) **Figure 1(a)** shows a rocket launched into space. Based on the figure:

Rajah 1(a) menunjukkan sebuah roket dilancarkan ke angkasa. Berdasarkan pada rajah tersebut:



Figure 1(a)

Rajah 1(a)

i. Name the best Newton's Law to describe the situation.

Namakan Hukum Newton yang sesuai untuk menggambarkan situasi tersebut.

[2 marks]

[2 markah]

ii. Define the Newton's Law in Question 1(a)(i).

Takrifkan Hukum Newton pada Soalan 1(a)(i).

[3 marks]

[3 markah]

CLO1
C3

- (b) A plate is subjected to the forces F_1 , F_2 and F_3 as shown in **Figure 1(b)**. The magnitude of F_1 , F_2 and F_3 are 4 kN, 6 kN and 5 kN respectively. Calculate:

*Satu kepingan plat dikenakan daya F_1 , F_2 dan F_3 seperti yang ditunjukkan pada **Rajah 1(b)**. Nilai daya F_1 , F_2 dan F_3 adalah 4 kN, 6 kN dan 5 kN. Kirakan:*

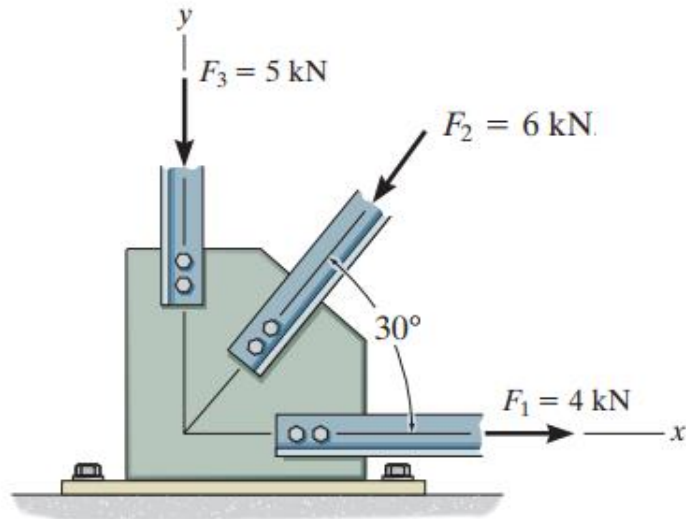

Figure 1(b)

Rajah 1(b)

- i. The magnitude of the resultant of these three forces.

Nilai paduan bagi ketiga-tiga daya tersebut.

[7 marks]
[7 markah]

- ii. The direction of the resultant force measured clockwise from the positive x axis.

Arah paduan daya yang diukur arah jam dari paksi positif x.

[3 marks]
[3 markah]

CLO2
C3

- (c) A pin is subjected to the three forces as shown in **Figure 1 (c)**. Calculate:
Pin tertakluk kepada tiga daya seperti yang ditunjukkan dalam **Rajah 1 (c)**.

Kirakan:

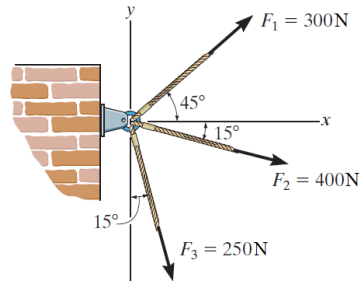
**Figure 1(c)**

- i. The magnitude of the resultant of these three forces.

Magnitud paduan ketiga-tiga daya ini

[7 marks]

[7 markah]

- ii. The direction of the resultant force measured counter clockwise from the positive x axis.

Arah daya paduan diukur melawan arah jam dari paksi x positif

[3 marks]

[3 markah]

QUESTION 2
SOALAN 2CLO1
C2

- (a) i. Interpret velocity and acceleration of particles.

Tafsirkan halaju dan pecutan bagi sesuatu zarah.

[4 marks]

[4 markah]

- ii. Explain the concepts of kinematics of particles with related equation.

Terangkan konsep kinematik zarah dengan persamaan yang berkaitan

[6 marks]

[6 markah]

CLO2
C2

- (b) A car moves from rest with constant acceleration 0.8 m/s^2 to reach velocity 10.5 m/s . Then, the car moves with constant velocity along 3.2 km . Then, the car slows down constantly for 25 seconds before it stops. By using a simple diagram, discuss a v-t graph of the journey.

Sebuah kereta bergerak dari keadaan rehat dengan pecutan seragam 0.8 m/s^2 untuk mencapai kelajuan 10.5 m/s . Kemudian, kereta tersebut bergerak dengan halaju seragam sejauh 3.2 km . Seterusnya, kereta memperlahankan kelajuan secara seragam selama 25 saat sebelum ia berhenti. Dengan menggunakan gambarajah ringkas, bincangkan graf perjalanan v-t tersebut.

[5 marks]

[5 markah]

CLO2
C3

- (c) The position of a cyclist traveling along a straight road is described by the s-t graph in Figure 3(c). Based on the graph:

Kedudukan penunggang basikal yang bergerak di sepanjang garis lurus ditunjukkan dalam graf s-t seperti pada Rajah 2(c). Berdasarkan graf:

- i. Calculate the position of cyclist when $t = 15$ s.

Kira kedudukan penunggal basikal apabila $t = 15$ s.

[2 marks]

[2 markah]

- ii. Construct the v-t and a-t graph for the same 20 s time interval.

Bina graf v-t dan a-t untuk sela masa 20 s yang sama.

[8 marks]

[8 markah]

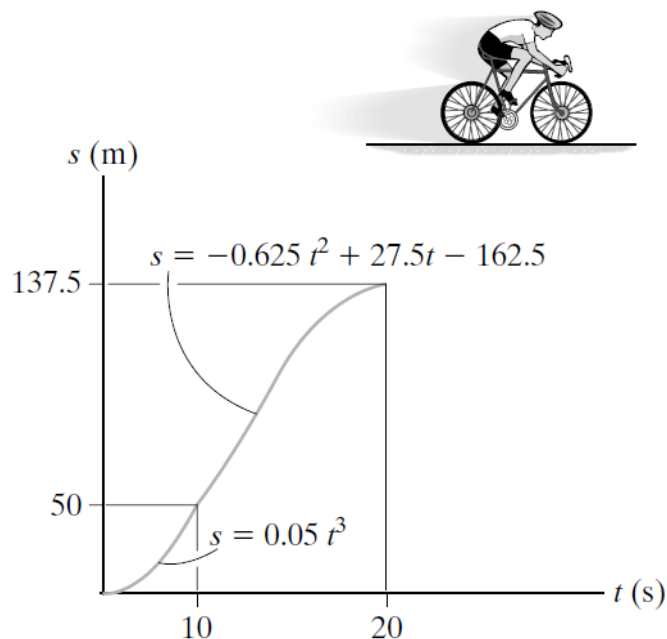

Figure 2 (c)

Rajah 2(c)

SOALAN TAMAT

LIST OF FORMULA

**STATICS**

1. TRIANGLE RULE

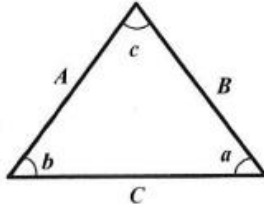

Sine law:

$$\frac{A}{\sin a} = \frac{B}{\sin b} = \frac{C}{\sin c}$$

Cosine law:

$$C = \sqrt{A^2 + B^2 - 2AB \cos c}$$

2. ADDITION OF SYSTEM OF COPLANAR FORCE

$$(\rightarrow) \Sigma F_x = F_{1x} + F_{2x} - F_{3x}$$

$$(+\uparrow) \Sigma F_y = F_{1y} - F_{2y} + F_{3y}$$

$$F_R = \sqrt{(\Sigma F_x)^2 + (\Sigma F_y)^2}$$

$$\theta = \tan^{-1} \left| \frac{\Sigma F_y}{\Sigma F_x} \right|$$

3. CARTESIAN VECTOR

$$\mathbf{A} = A_x \mathbf{i} + A_y \mathbf{j} + A_z \mathbf{k}$$

$$\mathbf{u}_A = \frac{\mathbf{A}}{A} = \frac{A_x}{A} \mathbf{i} + \frac{A_y}{A} \mathbf{j} + \frac{A_z}{A} \mathbf{k}$$

$$\cos^2 \alpha + \cos^2 \beta + \cos^2 \gamma = 1$$

$$\mathbf{F}_R = \Sigma \mathbf{F} = \Sigma F_x \mathbf{i} + \Sigma F_y \mathbf{j} + \Sigma F_z \mathbf{k}$$

$$\mathbf{r} = (x_B - x_A) \mathbf{i} + (y_B - y_A) \mathbf{j} + (z_B - z_A) \mathbf{k}$$

$$\mathbf{F} = F \mathbf{u} = F \frac{\mathbf{r}}{r}$$

4. EQUILIBRIUM OF PARTICLE

$$\Sigma \mathbf{F} = 0$$

$$F = ks$$

DYNAMICS

1. RECTILINEAR MOTION OF PARTICLES

$$v = dx/dt$$

$$a = dv/dt$$

2. UNIFORM RECTILINEAR MOTION

- v constant

$$x = x_0 + vt$$

- a constant

$$v = v_0 + at$$

$$x = x_0 + v_0 t + \frac{1}{2} at^2$$

$$v^2 = v_0^2 + 2a(x - x_0)$$

3. WORK OF FORCE

$$U_{1 \rightarrow 2} = (F \cos \alpha) \Delta x$$

4. KINETIC ENERGY OF PARTICLE

$$T = \frac{1}{2} m v^2$$

$$U_{1 \rightarrow 2} = T_2 - T_1$$