



POLITEKNIK SULTAN SALAHUDDIN ABDUL AZIZ SHAH

SMART BOX COOLER

NAMA	NO. PENDAFTARAN
NURFITRIYANI BINTI MOHD ARIS	08DPB17F1117
HANIS NABILA BINTI MOHD SHAARI	08DPB17F1159
EVA MARIA JOEL JENET	08DPB17F1201
FARAH AZRA DAYANA BINTI ARIFIN	08DPB17F1147

JABATAN KEJURUTERAAN AWAM

JUN 2019

POLITEKNIK SULTAN SALAHUDDIN ABDUL AZIZ SHAH

SMART BOX COOLER

NAMA	NO. PENDAFTARAN
NURFITRIYANI BINTI MOHD ARIS	08DPB17F1117
HANIS NABILA BINTI MOHD SHAARI	08DPB17F1159
EVA MARIA JOEL JENET	08DPB17F1201
FARAH AZRA DAYANA BINTI ARIFIN	08DPB17F1147

Laporan ini dikemukakan kepada Jabatan Kejuruteraan Awam sebagai memenuhi sebahagian syarat penganugerahan Diploma Perkhidmatan Bangunan

JABATAN KEJURUTERAAN AWAM

JUN 2019

PERAKUAN KEASLIAN DAN HAK MILIK

Laporan projek bertajuk Smart Box Cooler ini telah dikemukakan, disemak serta disahkan sebagai memenuhi syarat dan keperluan Penulisan Projek seperti yang telah ditetapkan.

Disemak oleh :

Nama Penyelia : Puan Rosida Binti Ahmad

Tandatangan Penyelia :

Tarikh :

Disahkan oleh :

Nama Penyelaras :

Tandatangan Penyelaras :

Tarikh :

“Kami akui karya ini adalah hasil kerja kami sendiri kecuali nukilan yang setiap satunya telah kami jelaskan sumbernya”

1. Tandatanganan :

Nama :

No. Pendaftaran :

Tarikh :

2. Tandatanganan :

Nama :

No. Pendaftaran :

Tarikh :

3. Tandatanganan :

Nama :

No. Pendaftaran :

Tarikh :

4. Tandatanganan :

Nama :

No. Pendaftaran :

Tarikh :

APPRECIATION

Grateful to Allah S.W.T and a support from our supervisor, Puan Rosida Bt Ahmad. We are able to finish our final project 'SMART BOX COOLER'. This project was created to give benefits to all users and hope that this project and make their life easier.

Without the cooperation of all parties, especially Polytechnic Sultan Salahuddin Abdul Aziz Shah and our supervisor, we believe that this project and final report cannot be completed properly without the aid of the party. Moreover, it is a testimony of our project and our careers in the future.

After a year from semester 4 to semester 5, a project was implemented for students who have successfully designed to be used as experience in making projects and gained as much knowledge as possible to make it easier for students when out as graduates later.

During the process of making this project, probably there is a lot of mistakes are made without us realizing it was a mistake. Therefore, we seek for forgiveness and thousands of grateful to the Polytechnic Sultan Salahuddin Abdul Aziz Shah and our supervisor. Also, all the staff whether involved or not. A lot of guidance and cooperation for our project.

Lastly, we hope from this final project report can meet all requirement set out in addition to one of the conditions in the award-Polytechnic Polytechnic diploma for Malaysian. Thank you.

ABSTRACT

Drinking enough water can help you look your best. When you drink plenty of water, you keep it healthy and hydrated. And because water contains zero calories, water can be an excellent tool for managing your weight, as well. The problem that most of the consumers facing is that they need to cold water by using refrigerator. This is because they do not have any device that can cool their water without using refrigerator or ice medium. Next, the consumers need to cool water in a long period of time. Time taken for a 500ml of canned water in refrigerator need 25 minutes to cool and 1500ml of mineral water need one and a half hour to cool. Lastly, they also have a problem in finding cold water resources. When we are out from our house, we do not have any cold water supply as in our house. So, we need to buy a cold water from the store but the coldness of the water would not stand long. We are inventing a product that can be used to cool water and also the food. Our invention is convenient, ergonomic and environmental friendly for consumers to use. This product can reduce the amount of consumers that do not get cold water supply in their daily life. They also can keep their food in cold temperature so that they can eat for longer time.

Keywords : Cold Water, Cold Temperature, Box

Contents

CHAPTER 1	10
INTRODUCTION	10
1.1 INTRODUCTION	10
1.2 BACKGROUND RESEARCH	11
1.3 PROBLEM STATEMENT	12
1.4 OBJECTIVE	12
1.5 SCOPE	13
1.6 IMPORTANCE OF RESEARCH	14
1.7 DEFINITION OF TERMS	14
1.8 CONCLUSION	15
CHAPTER 2	16
LITERATURE REVIEW	16
2.1 INTRODUCTION	16
2.2 CONCEPT/ THEORY	17
2.3 PREVIOUS STUDY	18
2.4 CONCLUSION	37
CHAPTER 3	38
METHODOLOGY	38
3.2 RESEARCH DESIGN	39
3.3 METHOD OF DATA COLLECTION	46
3.4 RESEARCH INSTRUMENT	50
3.5 SAMPLING TECHNIQUE	51
3.6 DATA ANALYSIS METHOD	52
3.7 CONCLUSION	58
CHAPTER 4	59
RESULTS	59
4.1 INTRODUCTION	59
4.2 ANALYSIS & DESCRIPTIVE RESULTS	59
4.3 ANALYSIS & EMPIRICAL RESULTS	60
4.4 CONCLUSION	63
CHAPTER 5	64

DISCUSSION AND CONCLUSION 64
 5.1 INTRODUCTION 64
 5.2 DISCUSSION..... 64
 5.3 CONCLUSION 65
 5.4 SUGGESTION..... 65
 5.5 CHAPTER SUMMARY 66
REFERENCES..... 67
APPENDIX..... 71
 I . GANTT CHART 71
 II. QUESTIONNAIRE 72
 III . COSTING..... 74
 IV . LIST OF COMPONENTS 75

LIST OF FIGURE

NO.	LIST
1.	Figure 1.1 : Bottled Water Understanding
2.	Figure 1.2 : Types of Bottle Materials
3.	Figure 1.3 : Air Conditioning System
4.	Figure 1.4 : Liquid-to-liquid Cooling System
5.	Figure 1.5 : Chilled Water System
6.	Figure 1.6 : Bottle Cooler
7.	Figure 1.7 : Water Capacity
8.	Figure 1.8 : Peltier
9.	Figure 1.9 : Heat Sink
10.	Figure 1.10 : Daily hydration for athletes
11.	Figure 1.11 : Ensuring workers drink enough water
12.	Figure 2.1 : Sketch 1
13.	Figure 2.2 : First design of product
14.	Figure 2.3 : Second design of product
15.	Figure 2.4 : Latest design of product
16.	Figure 2.5 : Procedure for first design product
17.	Figure 2.6 : Procedure for latest design product
18.	Figure 2.7 : Answer from respondent
19.	Figure 3.1 : Temperature taken for first design product
20.	Figure 3.2 : Temperature taken for latest product
21.	Figure 3.3 : Answer from respondent
22.	Figure 4.1 : Discussion with team

CHAPTER 1

INTRODUCTION

1.1 INTRODUCTION

In 1973, DuPont engineer Nathaniel Wyeth patented Polyethylene terephthalate (PET) bottles, the first bottle to be able to withstand the pressure of carbonated drinks. He invented 25 process and product and his most famous invention was the bottle he patented in 1973 made of a kind of polyester called polyethylene terephthalate or PET.

Typically, the plastic bottles used to hold portable water and other drinks are made from polyethylene terephthalate (PET), because the material is both strong and light. PET is a thermoplastic polymer that can be either opaque or transparent, depending on the exact material composition. PET is produced from petroleum hydrocarbons, through a reaction between ethylene glycol and terephthalic acid. To produce plastic bottles, the PET is first polymerized to create long molecular chains.

There are many types of bottles that have been manufactured for examples, glass bottles, aluminium bottles, and plastic bottles. These bottles were manufactured with different materials but serve the same purpose that is to store water so that it can be carried around. As for plastic bottles, the materials are High-density polyethylene (HDPE), fluorine treated HDPE, low-density polyethylene (LDPE), and polyethylene terephthalate (PET).

The advantages of using a plastic is that it is rugged and safe, energy saving, ease of production, economical and safe to use.

1.2 BACKGROUND RESEARCH

Water is an amazing creation of nature. It may not have any taste but the way it soothes the human body with its nutrients and soothing effects, there can be no alternative to it. 70% of our body comprises of water and enables all our organs to perform just like the way they are supposed to. It is said that a human can go for a period of 2 weeks if must; without eating but cannot survive without drinking water for 4 days. Our body uses water in all its cells, organs, and tissues to help regulate its temperature and maintain other bodily functions. Because our body loses water through breathing, sweating, and digestion. It is important to re-hydrate by drinking fluids and eating foods that contain water. The amount of water we need depends on a variety of factors, including the climate we live in, how physically active we are, and whether we are experiencing an illness or have any other health problems. (EVERYDAYHEALTH, By Jen Laskey. Medically reviewed by Sanjai Sinha, MD. 2/16/2015)

Staying hydrated has proven benefits for people's mental and physical health. Drinking cold water during exercise can help our body from overheating and make our workout session more successful. This is because drinking cold water makes our body to maintain at a lower core temperature. Cold water boosts the metabolism rates. Recent studies in various health journals state that drinking cold water speeds up the process that activates the mechanism leading to burning of calories for the purpose of heat generation in the body. Cold water gives us pleasure and uplift our mood. This is also a reason why people having aggressive behaviors are offered a cold glass of water, as it fuels the happy hormones in the body and cools down the aggression. Lastly, cold water speeds up the process of natural glow and along with smooth skin texture. A lot of people are unaware of the fact that warm water strips off your skin from essential oils responsible for skin health and natural glow; while cold water does the job right. Cold water intake encourages the blood to rush to the surface of skin giving a healthy glow and smaller pores.

1.3 PROBLEM STATEMENT

The problem that most of the consumers facing is that they need to cold water by using refrigerator. This is because they do not have any device that can cool their water without using refrigerator or ice medium. Next, the consumers need to cool water in a long period of time. Time taken for a 500ml of canned water in refrigerator need 25 minutes to cool and 1500ml of mineral water need 1 and a half hour to cool. Lastly, they also have a problem in finding cold water resources. When we are out from our house, we do not have any cold-water supply as in our house. So, we need to buy a cold water from the store, but the coldness of the water would not stand long.

We are inventing a product that can be used to cool water and it is portable. Our invention is convenient and environmentally friendly for consumers to use. This product can reduce the number of consumers that do not get cold water supply in their daily life.

1.4 OBJECTIVE

The objective of this research is to investigate:

1. To facilitate consumer to get cold water supply when they are at a place that are hard to find cold water resource.
2. To accelerate the time taken to cool water.
3. To produce a product that can cool water at the same time can be carry anywhere.
4. As another alternative for water cooling device.

1.5 SCOPE

We concern about the material product. Material that we use basically is plastic BPA free safe and stainless steel. This is because glass is not suitable and easy to break when consumer use it. So, it will be not safe when consumer use our product.

Besides that, scope of this study is about the target market of the people who need this product. It is devoted to students, athletes and workers who are around Polytechnic sultan Salahuddin Abdul Aziz Shah, Stadium Shah Alam and around Teluk Panglima Garang.

The scope of this study was chosen because of the community especially athletes requiring water, especially cold water to adequately hydrate their bodies from dehydration by weather in Malaysia in particular. (This study was made around December 2018 to June 2019).

Lastly, our scope is about the water capacity. Most of the health messages we hear are about making sure we drink enough water, especially in hot weather, when you had a tummy bug or when you are exercising.

You have probably heard that eight glasses a day is what you should aim for. There are Nutrient Reference Values advising that adult men should drink 2.6 litres of water per day (about 10 cups) and adult women should drink 2.1 litres per day (about eight cups). In that case, our product is aiming for 1.5 litres until 2 litres water bottle. It is a best way to make sure that our consumer has enough drinking water in their daily life. When we, as a human did not get enough water in our body, we might get hydration that can cause problem in our basic life.

1.6 IMPORTANCE OF RESEARCH

This research has several importance, those are to facilitate people to get cold water supply. As what we all know, cold water can only be supply by refrigerator or using ice. So, we are making our product that will cool water without using refrigerator.

Next, it is to improve the awareness of the benefits of cold water to the consumer. We believed that many people think that drinking cold water have a lot of disadvantage, but we are making this product to make people aware that drinking cold water is as good as drinking warm water.

Lastly, our research is to make sure that this product can saves the time and energy of the consumers to get cold water supply. This is because we are producing a product that can cool water and it is easy to carry anywhere (portable). This can save the consumer time in finding cold water supply.

1.7 DEFINITION OF TERMS

SMART =

S – Specific

M – Measurable

A - A Portable Bottle

R – Rechargeable

T - Time for cooling water

BOX - A stainless steel or plastic container that is use to store things.

COOLER- A container or apparatus in which something may be cooled or kept cool.

PELTIER MODULE- Peltier devices are literally heat pumps, which have two sides; a hot side, and a cold side. When a voltage is applied (around 12V), heat ‘magically’ pumped from the cold side to the hot side through the semiconductor junction. The primary function of a Peltier device is for cooling.

HEAT SINK- A heat sink (also spelled as heatsink) is a passive heat exchanger that transfers the heat generated by an electronic or a mechanical device to a fluid medium, often air or a liquid coolant, where it is dissipated away from the device, thereby allowing regulation of the device's temperature as optimal levels.

HEAT SINK COMPOUND- Thermal paste is a very high heat conductive paste that is used between two objects (usually a heat sink and a CPU/GPU) to get better heat conduction. It fills in all those microscopic imperfections on the heat sink and CPU/GPU that can trap air in them and cause a loss in heat sink's performance.

1.8 CONCLUSION

Cold water can bring many benefits to the consumers. As we know, people nowadays have a problem in finding cold water resources. This problem occurs because the lack of facilities. The overall for this chapter such as background research, problem statement, objectives and scope research have discussed about the difficulty of consumer to find the cold-water supply in this country. Therefore, the consumer must be creative and innovative in finding initiative to solve the problem so that they can achieve the target desired.

CHAPTER 2

LITERATURE REVIEW

2.1 INTRODUCTION

In this chapter contains some statements taken from several articles as literature review. This article is a reference and helps in supporting the implementation of this project. There are several subtopics in this chapter is on the designs used for bottles, the materials used to cool the water and the efficiency of a fan system to cool the water. Most articles are obtained from internet sources.

The purpose of the main literature review is to distinguish what has been studied with what needs to be learned. The literature review has been linked to its own effects. Among the main topics of literature reviews are about bottled water, time to cool water, the capacity of water needed by humans per day and the user's target.

2.2 CONCEPT/ THEORY

When we talk about cooling method, the first thing we will remember is refrigeration. How cooling method in refrigeration works? There are number of methods by which the refrigeration can be achieved. They are broadly classified into two categories: Non-Cyclic and Cyclic methods of Refrigeration. Firstly, let us see non-cyclic methods. In the non-cyclic method of refrigeration there is no thermodynamic cycle followed for creating the cooling effect. There are two methods of non-cyclic refrigeration process as described below:

2.2.1 ICE REFRIGERATION

In this method the ordinary ice is used for keeping the space at temperature below the surrounding temperature. The temperature of ice is 0 degree Celsius hence it can be used to maintain the temperatures of about 5 to 10 degree Celsius. To use the ice for refrigerating effect a closed and insulated chamber is required. On one side of the chamber ice is kept while on the other side there is a space which is to be cooled where some material to be cooled can be placed. If the temperature below 0 degree Celsius is required, then the mixture of ice and salt is used. This method of cooling is still being used for cooling the cold drinks, keeping the water chilled in thermos, etc.

2.2.2 DRY ICE REFRIGERATION

Dry ice is the solid carbon dioxide having the temperature of -78 degree Celsius. Dry ice converts directly from solid state to gaseous; this process is called as sublimation. Dry ice can be pressed into various sizes and shapes as blocks or slabs. Dry ice is usually packed in the frozen food cartons along with the food that must be kept frozen for long intervals of time. When the dry ice gets converted into vapor state it keeps the food frozen. The process of dry ice refrigeration is now-a-days being used for freezing the food in aircraft transportation.

For our product, we decided to use Peltier, heat and other electric components that will make the water cold within the time that we expect.

2.3 PREVIOUS STUDY

2.3.1 BOTTLE

Although vessels to bottle and transport water were part of the earliest human civilizations, (Rong & Fa, 2013) bottling water began in the United Kingdom with the first water bottling at the Holy Well in 1621. The demand for bottled water was fueled in large part by the resurgence in spa-going and water therapy among Europeans and American colonists in the 17th and 18th centuries. The first commercially distributed water in America was bottled and sold by Jackson's Spa in Boston in 1767. (Hall, 2013) Early drinkers of bottled spa waters believed that the water at these mineral springs had therapeutic properties and that bathing in or drinking the water could help treat many common ailments.

The popularity of bottled mineral waters quickly led to a market for imitation products. Carbonated waters developed as means for approximating the natural effervescence of spring-bottled water, and in 1809 Joseph Hawkins was issued the first U.S. patent for "imitation" mineral water. (Back, Landa, & Meeks, *Bottled Water, Spas, and Early Years of Water Chemistry* (Groundwater Volume 33, Issue 4 ed.), 1995) As technological innovation in nineteenth century lowered the cost of making glass and improved production speed for bottling, bottled water was able to be produced on a larger scale and the beverage grew in popularity. (Hall, 2013) Bottled water was seen by many as a safer alternative to 19th century municipal water supplies that could be contaminated with pathogens like cholera and typhoid. By the middle of the century, one of America's most popular bottlers, Saratoga Springs, was producing more than 7 million bottles of water annually. (Hall, 2013)

In the United States, the popularity of bottled water declined in the early 20th century, when the advent of water chlorination reduced public concerns about water-borne diseases in municipal water supplies. However, it remained popular in Europe, where it spread to cafes and grocery stores in the second half of the century. In 1977, Perrier launched a successful advertisement campaign in the United States, heralding a rebirth in popularity for bottled water. (Hall, 2013) Today, bottled water is the second most popular commercial beverage in the United States, with about half the domestic consumption as soft drinks.

2.3.1.1 BOTTLE WATER SOCIAL PHENOMENON



Figure 1.1 : Bottled Water Understanding

Bottled water is the most dynamic market of the food and beverage industry. The term “bottled water” doesn’t refer to one single product, and the same designation can be given to qualify different goods, depending on the country of production. Three major types of bottled water can be identified.

In addition to these 3 major categories, the International Bottled Water Association (IBWA) considers 4 other categories of bottled waters: artesian water/artesian well water; drinking water; sparkling water; and well water. This large number of different categories still does not facilitate the consumer identification of the product purchased. In some cases, bottled water is simply bottled tap water. Different materials are used for the containers used for bottled water: glass; plastic (PVC and PET); and aluminum or steel cans. These containers have different shapes, colors and volume. They are an essential part of the bottled-water marketing process. In some cases, it is even possible to recognize the brand of the bottled water only by the shape and color of the packaging (e.g. Perrier).

The bottled water industry is very dynamic: numerous bottled water companies compete on this market. Although they can be extremely different, it is possible.

Bottled water consumption reflects a way of life. There is a long tradition in Europe for drinking bottled water. Nowadays, this habit has reached the rest of the world. Why do consumers choose to drink bottled water? In many cases, bottled water is an alternative to tap water. Consumers think it tastes better than tap water (no chlorine taste), they perceive it as being safer and of better

quality. They also look for security. Food scandals in industrialized countries and waterborne diseases in developing countries influence public attitudes. Bottled water is perceived as pure and safe, although this is not necessarily the case. (Ferrier, 2001)

2.3.1.2 TYPES OF BOTTLE MATERIALS



Figure 1.2 : Types of Bottle Materials

Different types of bottles are available today. Such as stainless-steel bottles, glass water bottle and plastic bottles. many advantages and disadvantages of the bottle on any bottle. with that we need to choose the best bottle to have.



Figure 1.2a

A stainless-steel water bottle is always a strong choice. Stainless steel is environmentally-friendly as it is one of the easiest materials to recycle. The bottles are designed so that the steel will not rust, making these bottles extremely durable and a great long-term investment. Stainless steel

is also non-reactive, so water bottles made of this material will not leach any chemicals into your beverage. This is beneficial if using reusable water bottle for water, coffee, smoothies, juice and even soda. If like cold drinks and hot drink, stainless steel is also a great choice as it can keep your cold beverage cool for up to 24 hours and your hot beverage warm for up to 6 hours. (Francisco, 2019). Stainless steel bottles are an effective, low-cost option. They're non-reactive, BPA free, and lightweight compared to glass or their insulated Stainless-Steel counterparts. You can't put hot water in these as directed by the manufacturers (and you'll burn your hands). But if you just need something for short amounts of time and don't care about insulation, it's tough to beat the value. Some folks prefer glass to avoid the metal smell or taste, but we found no issue with tastes on these bottles at all. (Vu, 2019)



Figure 1.2b

A glass water bottle is also a great choice to replace plastic water bottles, many people love glass water bottles because this option keeps your drinks tasting clean and fresh, and no one can argue that glass water bottles don't look slick and sophisticated. (Francisco, 2019) Glass water bottles eliminate plastic or metal tastes and chemicals / BPAs. Being able to see how much liquid is left without having to pick up or open the bottle is a nice perk. All were covered in a silicone sleeve for drop protection (no bottles cracked or shattered in our drop tests), but glass and silicone will not insulate your water. Condensation formed on all glass and silicone surfaces even though the silicone sleeves helped improve grip. (Vu, 2019)



Figure 1.2c

Reusable plastic water bottles is that many of the bottles today are BPA-free so you won't have to worry about this harmful chemical leaching into your liquid. However, in lieu of BPA, a new chemical called BPS is being used in its place. This chemical is potentially just as harmful as BPA is. What's even scarier is that companies do not have to mention whether to not their bottle contains BPS, so while they might claim "BPA-free," your plastic water bottle could still contain the potentially just-as-harmful replacement, BPS. Other negative to plastic water bottle is that they do not retain temperature so your cold drink will not stay cool and your hot drink will not stay hot. However, because many plastic water bottles are transparent, you'll at least be able to see how much of your room-temperature liquid is left. (Francisco, 2019) Plastic water bottles are geared towards sports and workouts. Even if you're not using it for those purposes you can still benefit from their sporty design features. Three of the bottles we tested had a flip-top lid that lets you drink using one hand, which we loved. They're also lightweight compared to glass and insulated bottles. Every bottle we tested was made of Tritan, a material claiming to be free of BPAs, estrogenic and androgenic activity. We still found these bottles to have the strongest smell though. (Vu, 2019)

While there are many different types of water bottles, some are better than others. The better types of bottle are stainless steels. What makes one bottle better than others might be style, danger of breaking, environmental concerns or portability, stainless steel is also a great choice as it can keep your cold beverage cool for up to 24 hours and your hot beverage warm for up to 6 hours. Because the stainless stain can make a water keep cold.

2.3.2 COOLER

Based on the dictionary, means of cooler is a cooler, portable ice chest, ice box, cool box, chilly bin, or esky is an insulated box used to keep food or drink cool. ice cubes are most commonly placed in it to help the contents inside stay cool. There are the basic method types of cooling systems that you can choose from to meet the cooling needs of your load.

2.3.2.1 COOLER SYSTEM AIR CONDITIONING

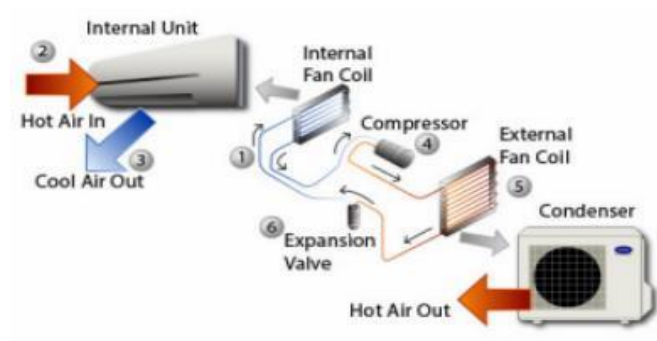

Figure 1.3 : Air Conditioning System

Air conditioning unit have a uses chemicals that convert from gas to liquid and back again quickly. These chemicals transfer the heat from the air inside your property to the outside air. The AC unit has three key parts. These are the compressor, the condenser, and the evaporator. The component compressor and condenser are typically located in the outside part of the air conditioning system. Inside the house is where you will find the evaporator. The cooling fluid reaches the compressor as a low-pressure gas. The compressor squeezes this gas/fluid, and the molecules in the liquid are packed closer together. The closer the compressor forces these molecules together, the higher the temperature and energy rise. This working fluid exits the compressor as a high-pressure, hot gas, and it moves to the condenser. The outside unit of an air conditioning system has metal fins all around the housing. These fins work like the radiator on a vehicle, and they help dissipate heat more quickly. (How Does Air Conditioning Work? 2017)

When the fluid leaves the condenser, it is much cooler. It's also changed from a gas to liquid because of the high pressure. The fluid makes its way into the evaporator through a minuscule, narrow hole and when the liquid reaches the other side of this passage, its pressure drops. When this happens, the fluid begins to evaporate to gas. As this occurs, the heat is extracted from the surrounding air. This

heat is required to separate the molecules of the liquid into a gas. The metal fins on the evaporator also help exchange thermal energy with the surrounding air.

When the refrigerant leaves the evaporator, it is once again a low-pressure, chilled gas. The process starts all over when it goes back to the compressor. There is a fan that's connected to the evaporator, and it circulates air around the inside of the property and across the fins of the evaporator. The air conditioner sucks air into the ducts through a vent. This air is used to cool gas in the evaporator, and as the heat is removed from the air, it's cooled. Ducts then blow air back into the house. (How Does Air Conditioning Work? 2017)

This process continues until the inside air of your home or business reaches the desired temperature. When the thermostat senses that the interior temperature is at the desired level, it shuts the air conditioner off. When the room heats up again, the thermostat turns the air conditioner back on until the preferred ambient temperature is achieved again.

2.3.1.2.THE METHOD TYPES OF COOLING LIQUID

There are the basic method types of cooling systems that you can choose from to meet the cooling needs of your load. Each one has its strengths and weaknesses. Liquid-to-liquid cooling systems is the one simplest of systems. In this type in your plant has an abundance of some type of cooling liquid already available to provide this coolant to the compressor. A liquid-to-liquid cooling system is an ideal situation It uses the well water on one side of an intermediate heat exchanger and a coolant such as glycol and water on the other side of the intermediate heat exchanger in a closed loop to cool the compressor. The heat is exchanged through the intermediate heat exchanger without fouling the heat exchanger. however, if the intermediate heat exchanger is selected properly it can be taken apart easily and cleaned. The most common intermediate heat exchangers are either plate and frame or shell and

tube type. The strength of a liquid-to-liquid cooling system is that it is relatively inexpensive to purchase and install. The components can be installed inside or outside. tube type.

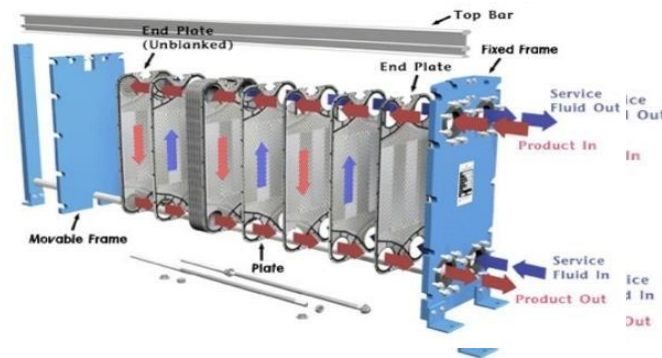

Figure 1.4 : Liquid-to-liquid Cooling System

Besides that, the type of cooling system is the chilled water system. A chiller normally has a mechanical compression device that converts energy into compressed refrigerant by using some type of compressor. The compressed refrigerant is piped to a condenser that rejects the heat from the refrigerant to the atmosphere or some type of liquid coolant. The compressed refrigerant changes state from a gas to a liquid in the condenser and is piped to an evaporator where it is metered or expanded in the evaporator. The expansion of the high-pressure liquid refrigeration reduces the temperature of the evaporator. The liquid to be cooled is pumped through the evaporator heat exchanger and heat is transferred to the refrigerant. The low-pressure vapor is carried back to the compressor and the cycle begins again for the refrigerant. The coolant flows from the evaporator heat exchanger to the load where the heat is transferred to the coolant in the load heat exchanger and then returns to the evaporator to repeat the cycle. The strengths of a chiller are that it can produce coolant temperatures far below the design wet bulb or dry bulb. It is not as dependent on the ambient temperature for the outlet coolant temperatures.

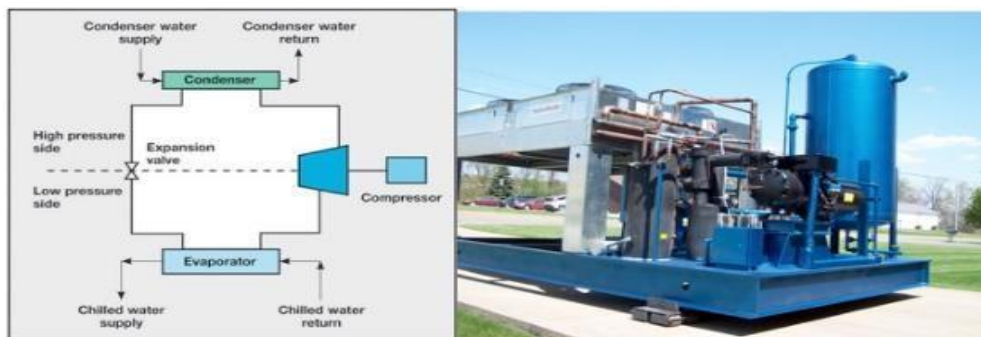

Figure 1.5 : Chilled Water System

3.2.3 BOTTLE COOLER



Figure 1.6 : Bottle Cooler

My two-liter bottle cooler includes a container and a lid. The container has a chamber with an enclosed bottom and an open top. The container has multiple walls displaced from each other creating annular pockets. The annular pocket that is nearest the chamber is filled with a freeze gel and the outer annular pocket is filled with an insulating foam. The open top of the container has external threads and the mouth of the lid is internally threaded with mating threads. The lid can be screwed onto the container to hold a two-liter bottle in place within the chamber. The dome of the lid has a hole with the neck of the two-liter bottle passing through the hole so that beverage contained within the two-liter bottle can be poured directly from the bottle as it is held in the cooler. The hole in the dome is internally threaded so that the cooler can also function as a container without an inserted two-liter bottle. In the latter case, a pour spout is provided with a threaded plug and a spout (United States Patent No. 5,406,808, 1995). The threaded plug mates with the internal threading in the hole of the dome to close the dome. The spout is externally Threaded, and a two-liter bottle cap can be threaded onto the spout to close it. When the pour spout is not in use, it can be stored in a pocket in the handle in the cooler. The pocket is internally threaded to mate with the external threads on the spout. The bottle cap is fitted within the opening contained in the threaded plug and a cover is fitted over the plug to seal it against outside elements.

The cover can be internally threaded to mate with the external threads on the plug. When the plug is in use, the cover can be stored by threading it onto an externally threaded stump contained on the bottom of the handle of the cooler. (United States Patent No. 5,406,808, 1995)

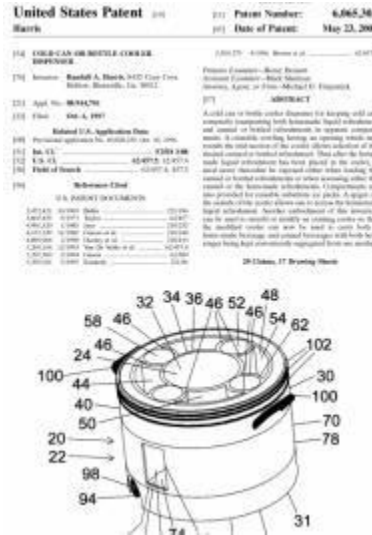

Figure 1.6a : Bottle Cooler

A cold can or bottle cooler dispenser for keeping cold and compactly transporting both homemade liquid refreshment and canned or bottled refreshments in separate compartments. A rotatable cowling having an opening which surrounds the mid-section of the cooler allows selection of the desired canned or bottled refreshment. thus, after the homemade liquid refreshment has been placed in the cooler, it need never thereafter be exposed either when loading the canned or bottled refreshments or when accessing either the canned or the homemade refreshments. Compartments are also provided for reusable substitute ice packs. A spigot on the outside of the cooler allows one to access the homemade liquid refreshment. Another embodiment of this invention can be used to retrofit or modify an existing cooler so that the modified cooler can now be used to carry both a home-made beverage and canned beverages with both beverages being kept conveniently segregated from one another. (United States Patent No. 6,065,303, 2000)

2.3.4 WATER CAPACITY

Water is our body's principal chemical component and a natural detoxifier but not many are aware about how much water should we ideally drink every day. Moreover, the popular 8 by 8 rule which says that one should drink eight glasses, each consisting of eight ounces of water, may not suit every individual. Says nutritionist Venu Adhiya Hirani, "While the general belief is to drink eight to 10 glasses of water, it is advisable to drink 12 to 15 glasses of fluids which includes water, tea, buttermilk, soup, etc. This would amount to an intake of around 2.5 liters of fluids every day."

According to nutritionist expert Nupur Krishnan, one's lifestyle plays an important role in deciding the amount of water that one should consume. "If you have a sedentary lifestyle and work in an air-conditioned environment where there is no scope for water loss via sweat, drinking more than 2 to 2.5 liters of water is not advisable. It will end up accumulating in your kidney and cause edema," says Krishnan. For moderate workers like salespersons, who are required to do physical activity, it is important to drink around three liters of water

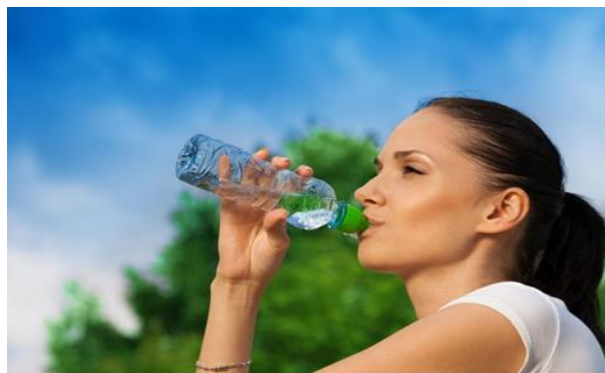

Figure 1.7 : Water Capacity

The amount of water you need depends on your lifestyle, size and individual body chemistry. To maintain health, the Institute of Medicine recommends 2.7 liters of water each day for women, which equals 91 ounces or about 11 cups. The IOM recommends 3.7 liters of water per day for men or 125 ounces, which is the amount of water in 12 cups. These recommendations include total water from beverages and food. According to the IOM, 80 percent of your daily water intake comes from beverages and 20 percent comes from food. (Gold, n.d.)

Recommended intake by age

There is no fixed amount of fluid recommended by age, but some patterns emerge among healthy individuals doing a moderate amount of activity in a temperate climate.

The following shows average water intake for infants and adults:

Age group	Average daily fluid intake
Infants	From 525 ml for a 3.5-kilo newborn to 1,200 ml for an 8-kilo infant per day, as breast or bottled milk
Adults	aged 19 to 30 years Average of 3.7 liters a day for men and 2.7 liters for women, depending on climate, activity, pregnancy status, and health

(MacGill, 2018)

2.3.5 HEALTH

As we know, our bodies consist around 60% water, give or take. So, it is essential for us to drink enough water every day. Staying hydrated is important. Firstly, water helps to maximize physical performance. If we do not stay hydrated, physical performance can suffer. This is particularly important during intense exercise or high heat. Dehydration can have a noticeable effect if you lose as little as 2% of your body's water content. However, it is not uncommon for athletes to lose up to 6-10% of their water weight via sweat. This can lead to altered body temperature control, reduced motivation, increased fatigue and make exercise feel much more difficult, both physically and mentally. Optimal hydration has been shown to prevent this from happening and may even reduce the oxidative stress that occurs during high intensity exercise. This is not surprising when you consider that muscle is about 80% water. So, if you exercise intensely and tend to sweat, then staying hydrated can help you perform at your absolute best.

Secondly, hydration has a major effect on energy levels and brain function. Your brain is strongly influenced by hydration status. Studies show that even mild dehydration (1-3% of body weight) can impair many aspects of brain function. In a study of young women, fluid loss of 1.36% after exercise impaired both mood and concentration and increased the frequency of headaches. Another similar study, this time in young men, showed that fluid loss of 1.59% was detrimental to working memory and increased feelings of anxiety and fatigue. A 1-3% fluid loss equals about 1.5-4.5 lbs. (0.5-2 kg) of body weight loss for a 150 lbs. (68 kg) person. This can easily occur through normal daily activities, let alone during exercise or high heat. Many other studies, ranging from children to the elderly, have shown that mild dehydration can impair mood, memory and brain performance. Mild dehydration (fluid loss of 1-3%) can impair energy levels and mood, and lead to major reductions in memory and brain performance.

Then, drinking water may help to prevent and treat headaches. Dehydration can trigger headaches and migraines in some individuals. Several studies have shown that water can relieve headaches in those who are dehydrated. However, this appears to depend on the type of headache. One study of 18 people found that water had no effect on the frequency of headaches but did reduce the intensity and duration somewhat.

The most important thing is drinking more water may help relieve constipation. Constipation is a common problem, characterized by infrequent bowel movements and difficulty passing stool. Increasing fluid intake is often recommended as a part of the treatment protocol, and there is some evidence to back this up. Low water consumption appears to be a risk factor for constipation in both young and elderly individuals. Carbonated water shows particularly promising results for constipation relief, although the reason is not entirely understood. Drinking Water May Help Treat Kidney Stones. Urinary stones are painful clumps of mineral crystal that form in the urinary system. The most common form is kidney stones, which form in the kidneys. There is limited evidence that water intake can help prevent recurrence in people who have previously gotten kidney stones. Higher fluid intake increases the volume of urine passing through the kidneys, which dilutes the concentration of minerals, so they are less likely to crystallize and form clumps. Water may also help prevent the initial formation of stones, but studies are required to confirm this.

Drinking More Water Can Help with Weight Loss. Drinking plenty of cold water can help you lose weight. This is since water can increase satiety and boost your metabolic rate. In two studies, drinking half a liter (17 ounces) of water was shown to increase metabolism by 24-30% for up to 1.5 hours. This means that drinking 2 liters of water every day can increase your total energy expenditure by up to 96 calories per day. The timing is important too and drinking water half an hour before meals is the most effective. It can make you feel fuller, so that you eat fewer calories. In one study, dieters who drank half a liter of water before meals lost 44% more weight, over a period of 12 weeks. It is best to drink water cold, because then the body will use additional energy (calories) to heat the water to body temperature. (Leech, 2017)

2.3.6 MATERIALS

2.3.6.1 PELTIER

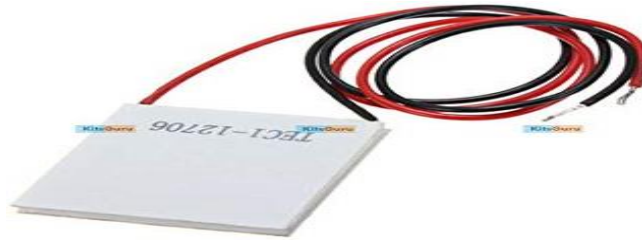

Figure 1.8 : Peltier

A Peltier is a solid-state thermoelectric module. When it is powered, it acts like a solid-state heat pump that transfers heat from one side of the device to the other. (jhyaden, 2009) Peltier have many advantages as it only require a DC electrical current in order to cool an object or an area. It is the opposite of a thermoelectric generator as it converts electricity into a different temperature. It can be used for various purposes and can be seen in several applications. Most common applications are used as portable coolers, cooling electronic components and small instruments. The cooling effect of a Peltier can be used to extract water from the air in dehumidifiers. Moreover, Peltier is also used in satellites and other aerospace technology in order to transfer the heat absorbed from direct sunlight to the shaded side of the machine.

Peltier have two sides of usage; the other side is for cooling and the other side is for heating. For Peltier coolers, it relies on a phenomenon known as the Peltier effect. If electricity is passed between the junction of two different types of metal, heat will flow from the upper junction to the lower junction. This is because the Peltier cooler tries to find a natural equilibrium by absorbing the extra electrons from the electrical current on one side and releasing them on the other side. However, in order to reverse the direction in which the heat is moving, the user simply must switch the current's polarity.

2.3.6.2 HEAT SINK

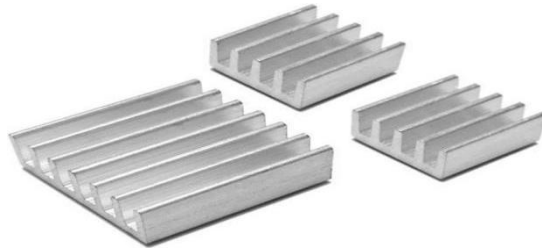

Figure 1.9 : Heat Sink

Heat sink is a device that incorporates with either a fan or other device that keep a hot component cool. There are two types of heat sink that is active heat sink and passive heat sink. An active heat sink uses the electronic device's power supply to connect to a fan or a Peltier to actively removes heat from the components by circulating air to cool the component or conduct heat away from it. Active heat sinks are often used in conjunction with passive heat sinks. But for passive heat sink, it has no mechanical parts that makes it dependable and easy to install within the components. Usually, the heat sink is manufactured in aluminum and are designated to spread heat over a large area then radiating it away from the delicate components. It is shaped in thin strands known as fins. The fins allow air to slip in between them and help carry away heat more efficiently than could be done by a solid block of aluminum of the same size. (bowney, 2017)

The heat sink has a thermal conductor that carries heat away from the central processing unit (CPU) into fins that provide a large surface area for the heat to dissipate throughout the rest of the computer, thus cooling both the heat sink and processor. Before the 1990s, heat sinks usually only necessary in large computers where the heat from the processor was a problem but with the introduction of faster processors, heat sinks became essential in almost every computer because they tended to overheat without the aid of cooling mechanism.

Heat sink are usually made of metal that serves as the thermal conductor that carries heat away from the CPU. One of the metals used in heat sinks is aluminum. Aluminum has a thermal conductivity of 235 W/mK. It is also cheap and is lightweight. The other materials to make a heat sink is copper. Copper has a very high thermal conductivity of 400 W/mK. But it is heavier and is more expensive than aluminum.

Based on the research above, we are using the aluminum heat sinks as it is cheap and lightweight. It fulfills the criteria to construct our bottle to be portable and lightweight because it can add very little weight to our product.

2.3.7 TARGET MARKET

Daily Hydration Needs For Athletes

FEBRUARY 3, 2011 · BY CINDY STONESMITH

Most people think my job as a running endurance coach is to motivate my clients to complete their prescribed daily workout. However, I often find myself motivating my clients to take the time throughout the day to fully recover and be prepared for the next day's training run. One of your first lines of defense for recovery is to hydrate properly throughout the day.

The human brain is made of 70% fluid and the human body is made up of 60-70% fluid; one could say we are mostly made up of fluid. You can't live two days without consuming some form of fluid. The need to balance the fluid in our body is a daily activity, one that is often over looked, even by athletes. On a rest day you'll lose 1-3 liters of water due to insensible fluid loss, depending on your size, age, athletic ability, and gender, through respiration, renal filtration, and metabolic processes.

If you want to train and race to the best of your abilities, proper daily hydration is imperative. Researchers concur that with as little as a 3% fluid loss, athletic performance is hindered, pace decreases and perceived effort increases. In laymen's terms...we bonk! This is not a new concept for athletes; you know you need to drink fluid during your races, but do you know how much fluid you need daily?

Figure 1.10 : Daily Hydration For Athletes

An athlete needs to drink a lot of water. Without enough liquid, they will face risk in stagnation in muscle growth, fat loss and bad health in general. 3 liters is the absolute minimum require for non-training days. For intense exercising such as frenetic increases metabolic activity permanently even at rest, so the water requirement is higher than average. But the actual fluid required by the body can be determined individually. The good guideline is to drink about 50ml per kilogram of body weight. At warm temperatures surrounding, athletes drink 1 or 2 liters more as they lose more liquid through sweat. (seana, 2014)

Ensuring workers drink enough water

June 1, 2008 No Comments     

I know that when it's hot I need to drink enough water to avoid heat stress, but how much is enough? Is there a ratio between how hot it is and how much water you drink?

Answered by Alyx Fier, president, True North LLC, Seattle, WA.

In the course of a day's work in the heat, you may sweat as much as 2-3 gallons, so it's essential that your water intake equals the amount of sweat produced. Unfortunately, you can't depend on thirst alone to let you know when and how much to drink. Usually by the time you feel thirsty you're already dehydrated and having to play catch-up. Instead of waiting until you feel thirsty, you should drink 5-7 ounces of fluids every 15-20 minutes to replenish the necessary fluids in the body. Cool water, as opposed to hot or cold, seems to be the most palatable and easy to drink.

Figure 1.11 : Ensuring workers drink enough water

A general worker sweat as much as 2-3 gallons of water a day. So, it is essential for them to take the equal amount of sweat produce. By having an easy access to water, it allows them to drink a cup of water very 15-20 minutes without interrupting their work flow. If they are delaying their time to drink a water and wait until their break time, they may end up in a defect situation which will degrade their work performance and safety. (fier, 2008)

2.3.8 BOX

Box (plural: boxes) describes a variety of containers and receptacles for permanent use as storage, or for temporary use, often for transporting contents. Boxes may be made of durable materials such as wood or metal, or of corrugated fiberboard, paperboard, or other non-durable materials. The size may vary from very small (e.g., a matchbox) to the size of a large appliance. A corrugated box is a very common shipping container. When no specific shape is described, a box of rectangular cross-section with all sides flat may be expected, but a box may have a horizontal cross section that is square, elongated, round or oval; sloped or domed top surfaces, or vertical edges. They are not always made up of squares.

Decorative or storage boxes may be opened by raising, pulling, sliding or removing the lid, which may be hinged and/or fastened by a catch, clasp, or lock. They have many types of box such as packaging box, storage boxes, electrical boxes and postal service boxes. Boxes for storing various items in can often be very decorative, as they are intended for permanent use and sometimes are put on display in certain locations.

A jewelry (AmE) or jewellery (BrE) box, is a box for trinkets or jewels. It can take a very modest form with paper covering and lining, covered in leather and lined with satin, or be larger and more highly decorated.

A humidor is a special box for storing cigars at the proper humidity, by means of absorbent materials that retain and moderate moisture coming from the cigars. Powered boxes can also maintain the right temperature.[citation needed]

A "strong box" or safe, is a secure lockable box for storing money or other valuable items. The term "strong box" is sometimes used for safes that are no longer portable boxes but are installed in a wall or floor for increased security.

A toolbox is used for carrying tools of various kinds. The term implies a container meant for portability rather than just storage, for instance with hinged lids, clasps or locks, reinforced corners, and handles. Toolboxes are usually very sturdy, but unlike a shipping box containing dunnage, are not expected to fully protect their contents if the box is inverted or upended.

The common storage box for tools, instruments, glassware, artworks, etc. is a sturdy box made to be longer-lasting and better-finished than a shipping box or crate. For instance, a box might be a rigid paperboard box instead of a corrugated box. Or it could be a wooden box with a sanded surface and mitered corners instead of a crude crate construction. A storage box may or may not have dunnage or cushions that protect the contents if the box is upended or shaken, and usually does not have hinges, latches or locks, but simply a cover. Boxwood gets its name from its superior properties for manufacturing this type of box, although those properties are equally useful when making a decorative box.

2.4 CONCLUSION

The purpose of this review was to view the trends in composition studies within the past forty years and see how commentary on student writing has changed and is still changing. It is clear from the research reviewed that evaluative commentary is very immersed and widely practiced throughout composition programs in today's universities. Along with this, it is also clear that the field of composition studies just in regard to the types of commentary that students receive on their writing is varied and continues to be studied and analyzed in order to most benefit composition students and society at large. Corrective vs. evaluative commentary is still being debated, though, and continues to be problematic in the discourse community of college composition and even high school writing as seen in Bardine et al.'s study. This field of inquiry is very important as at its center is a concern with helping students become better writers.

Helping students become better writers and getting students to see the importance in growing as independent writers is also extremely important in our current society with declining school budgets and liberal arts losing popularity and funding.

CHAPTER 3

METHODOLOGY

3.1 INTRODUCTION

Methodology is a matter of how the project is produced. It includes the components used, the procedures and techniques used for the product.

Methodology explains the way a problem is investigated and why a method and technique are used. The purpose of this methodology is to help understand more in detail by applying the method by making a description of the study process.

The Smart Box Cooler design is self-designed based on group members' suggestions and discussions. This innovation must consider the original aspects and theories in building this Smart Bottle Cooler. The resulting design must be less complicated, lightweight and portable. Component selection is based on research and testing so that Smart Bottle Cooler works perfectly. Even safety and comfort aspects are also preferred.

This chapter will briefly explain some important aspects in relation to the methodology used in this study. Concentration in this chapter will be given to study this "smart box cooler". In addition, this chapter will describe the procedures, procedures and programs for the implementation of the study.

3.2 RESEARCH DESIGN

3.2.1 IMPORTANCE OF DESIGN

Smart Box Cooler used a concept portable, easy to use and easy to bring so, you can enjoy and easy to get cool water sources. How can I said that the box easy to use? It works to simply, just with 3 steps and you can get your cool water. First, put some water bottle in the box. Second, press the switch. And the last, wait for about 30 minutes and you can get your cool water.

As a first step, the design and design specifications of Smart Box Cooler are essential to increase understanding. Some design sketches are as follows:

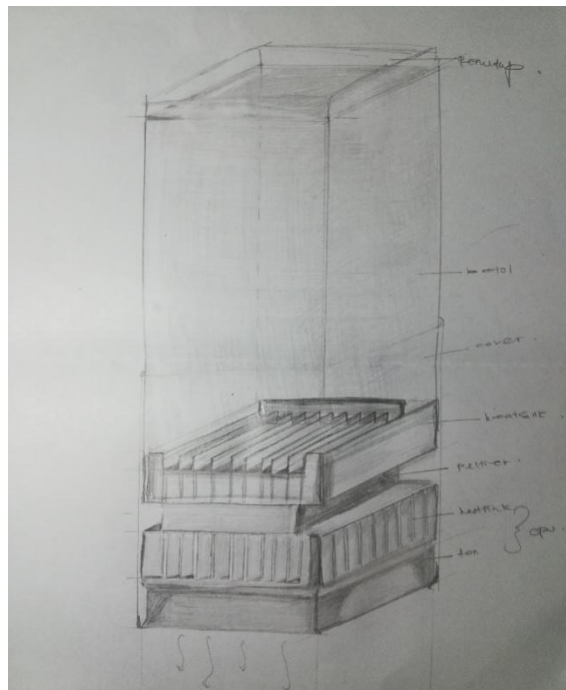

Figure 2.1 : Sketch 1

Design interests include initial designs and the basic introduction to design and its priority should be given to the cooling aspect, the durability of the temperature in the long run and the short period of cooling. Besides, you can design a user-friendly Smart Box Cooler.

First design of our product:

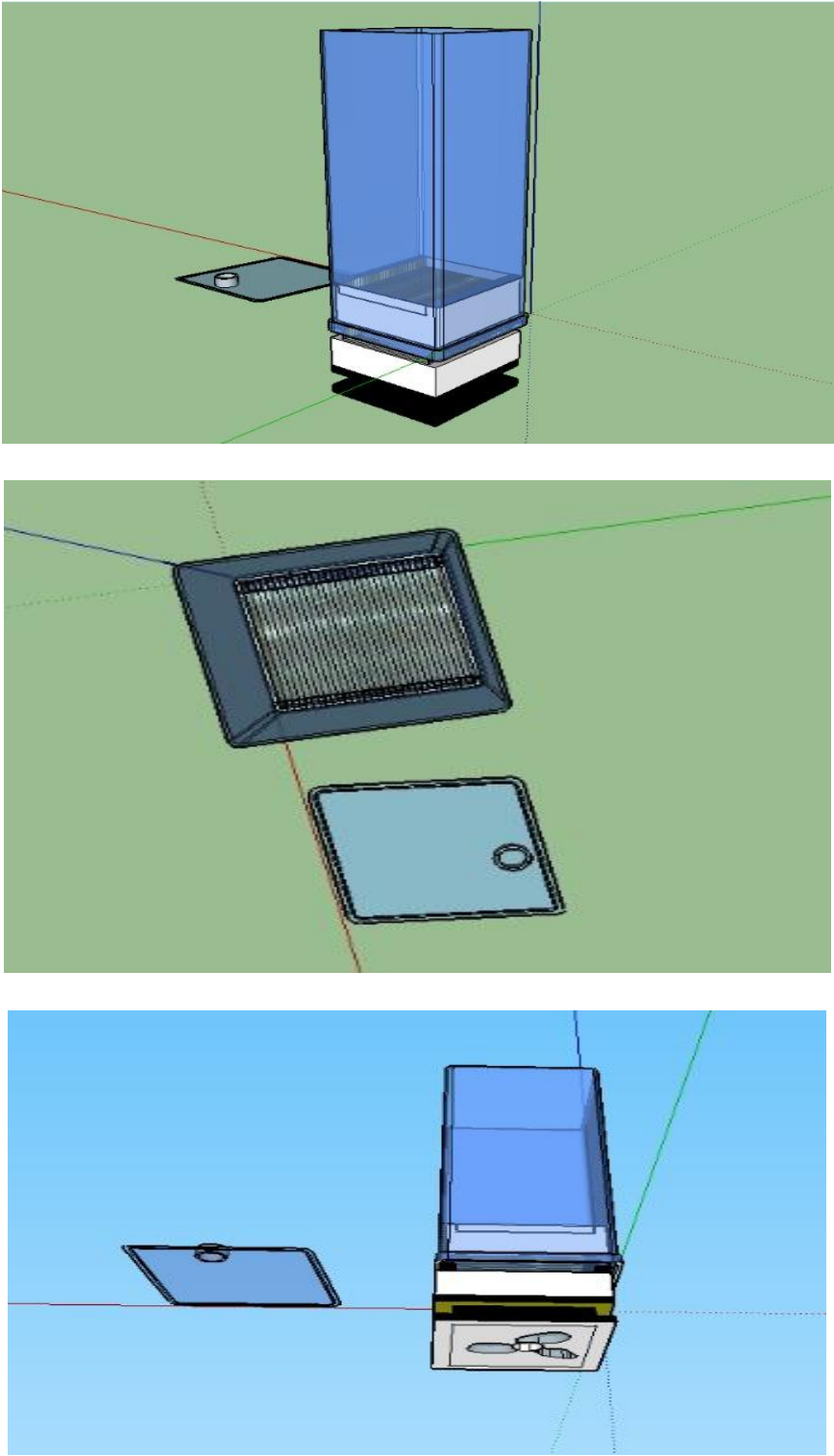

Figure 2.2 First design of product

Second design of product.

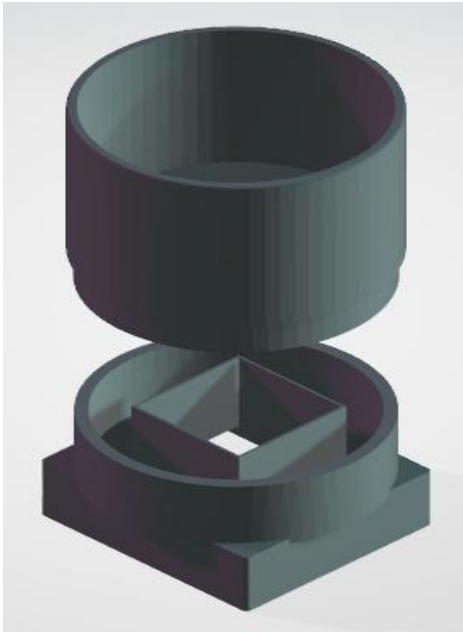
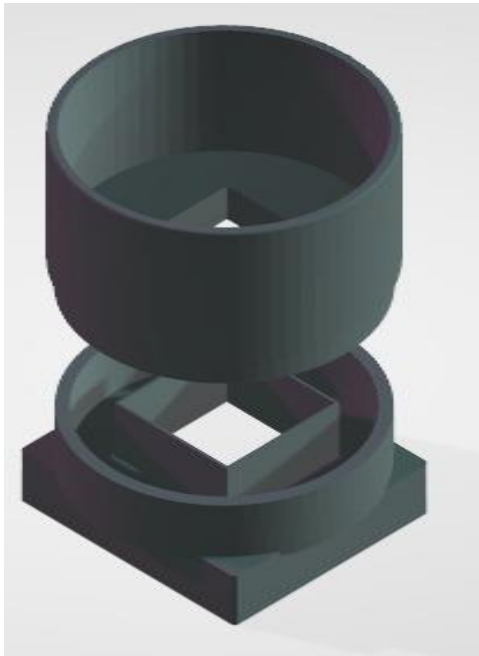
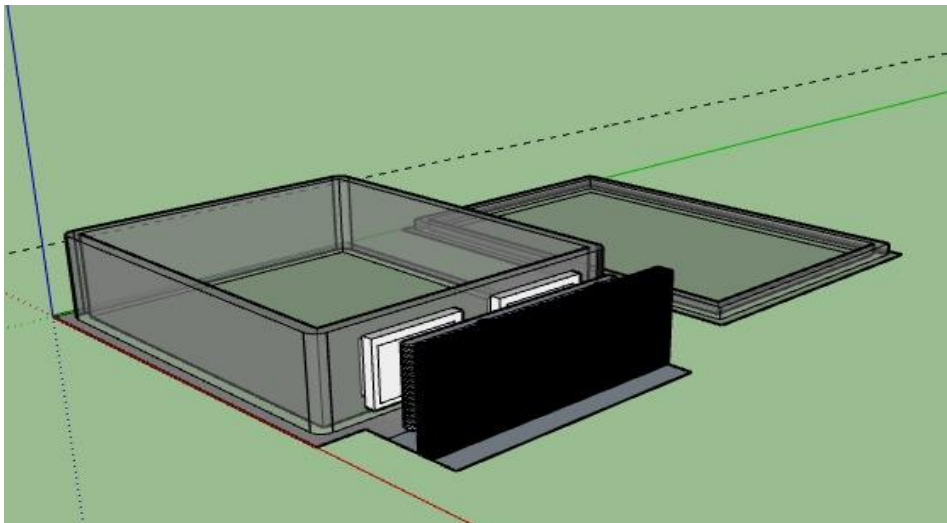
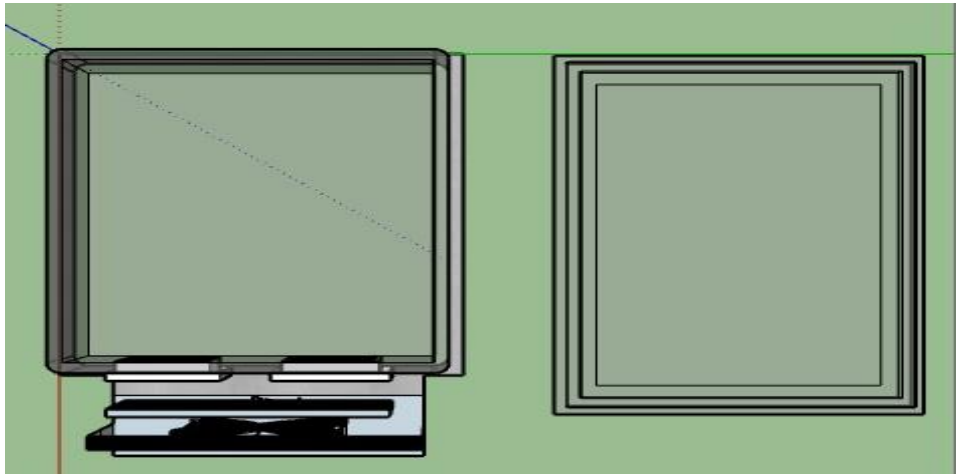

Figure 2.3 : Second design of product

Latest design of our product:



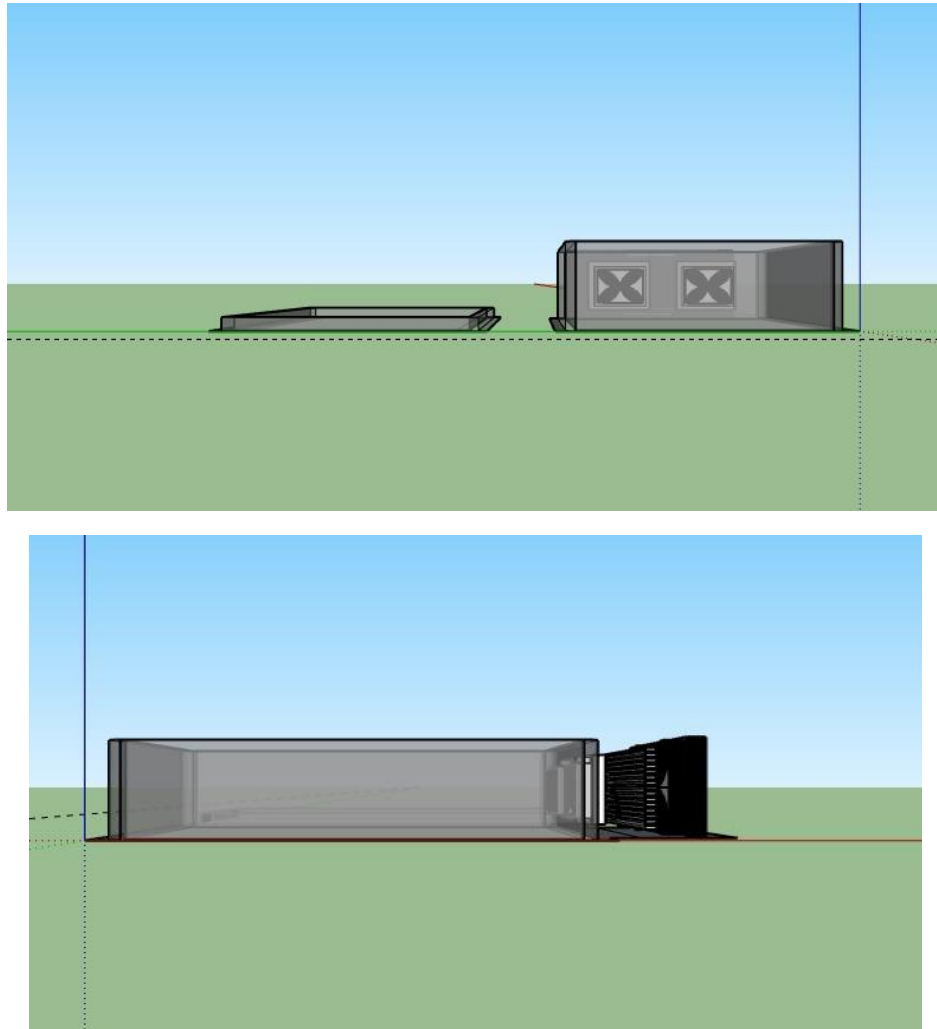

Figure 2.4 : Latest design of product

These are the design that we choose as our box design. The design of our bottle is in rectangular shape because if it falls to the ground, it would not roll off. From the front view, we can see that our box is connected to the component that is used to cool the bottle inside the box. Based on the upper view, we can see clearly that the component is in contact with the bottle inside the box. At the side of the bottle, the fan is used to eliminate the heat from the Peltier.

3.2.2 MAKING OF THE PRODUCT

First product procedure



Figure 2.5 : Procedure for first design product

Latest product procedure

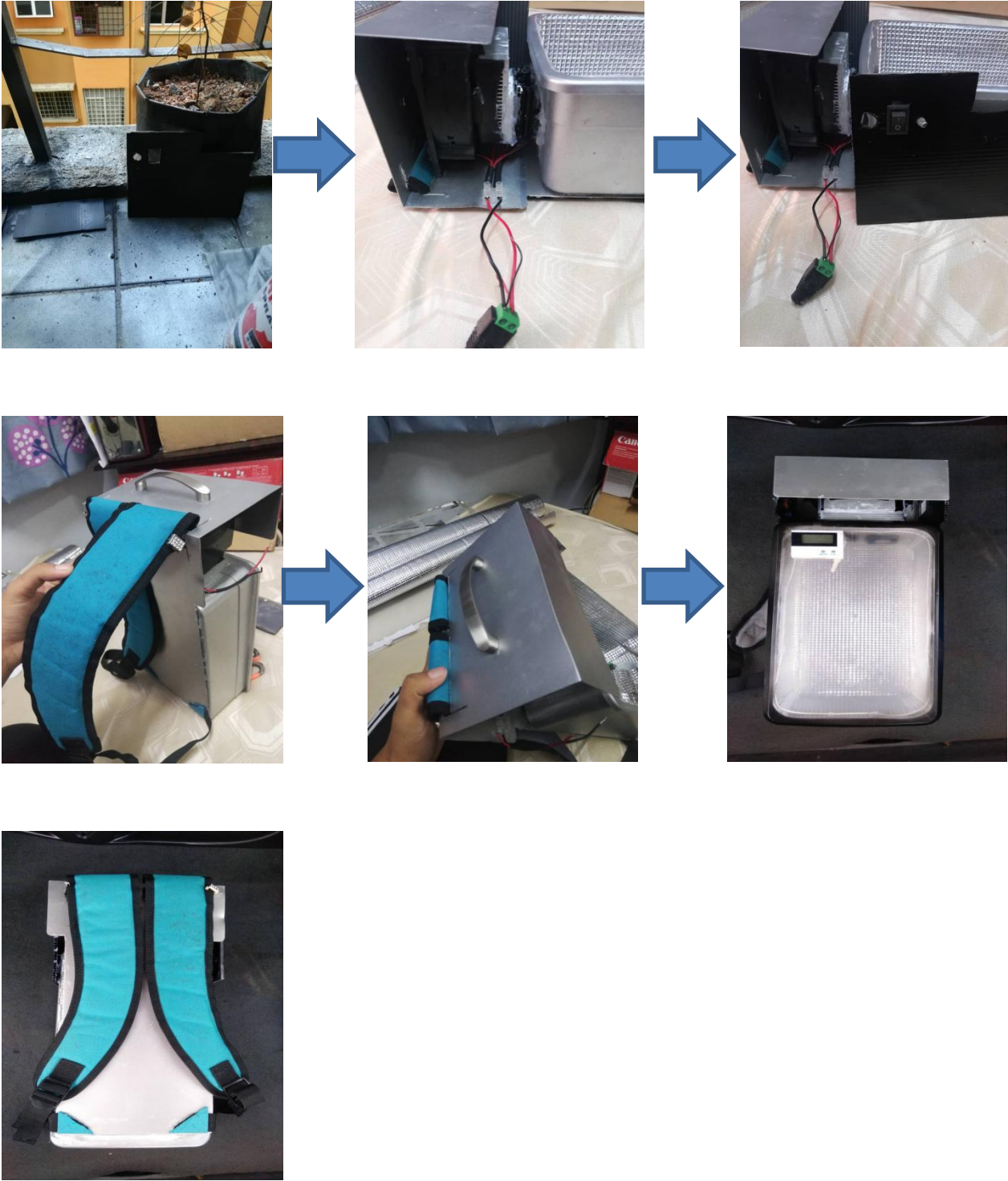

Figure 2.6 : Procedure for latest product

3.3 METHOD OF DATA COLLECTION

3.3.1 ENGINEERING TECHNIQUE

According to sources the research data are classified as Primary Data and secondary data. Understanding primary data or primary data definition is the data obtained directly from the subject by applying measurement tools or direct data retrieval tools to the subject as the source of information sought. This primary data is also called first hand data.

Secondary data definition or secondary data definition is data obtained through other parties, not directly obtained by researchers from the subject of research. This secondary data is also called Second hand data. Secondary data is usually a form of data documentation or available report data. Primary data and secondary data are usually a form of data documentation or available report data. Primary and secondary data can also be classified according to its type as quantitative data in the form of numbers and qualitative data in the form of categories.

3.3.2 FLOW CHART FROM THE START TO THE END OF THE PRODUCT

To make this project a success, several steps need to be taken and must be followed to ensure that the project will be smooth and successful. In case of problems, this flow chart should be referred to assist before or during the project. with this flow chart it encourages the use of a more orderly and systematic time because it can follow all the directions in so accurate and perfect. Among the steps that need to be followed are as follows:

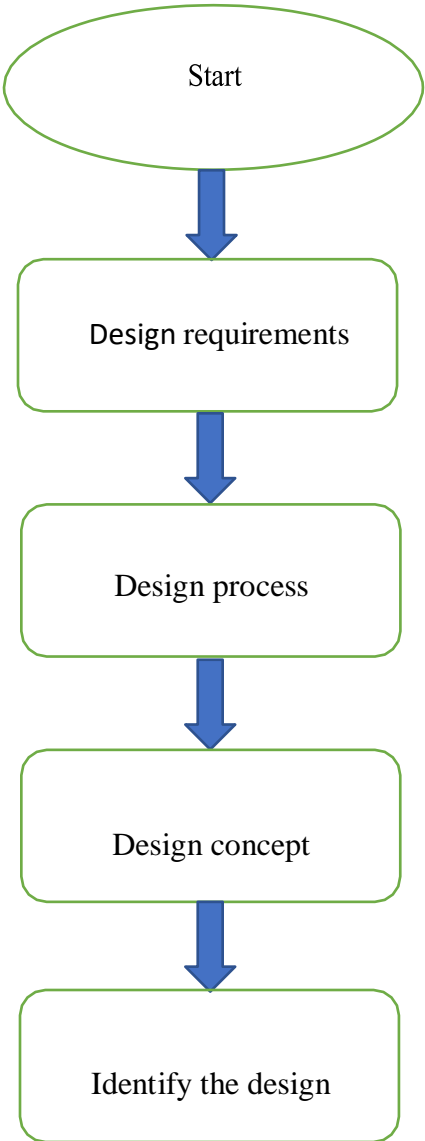

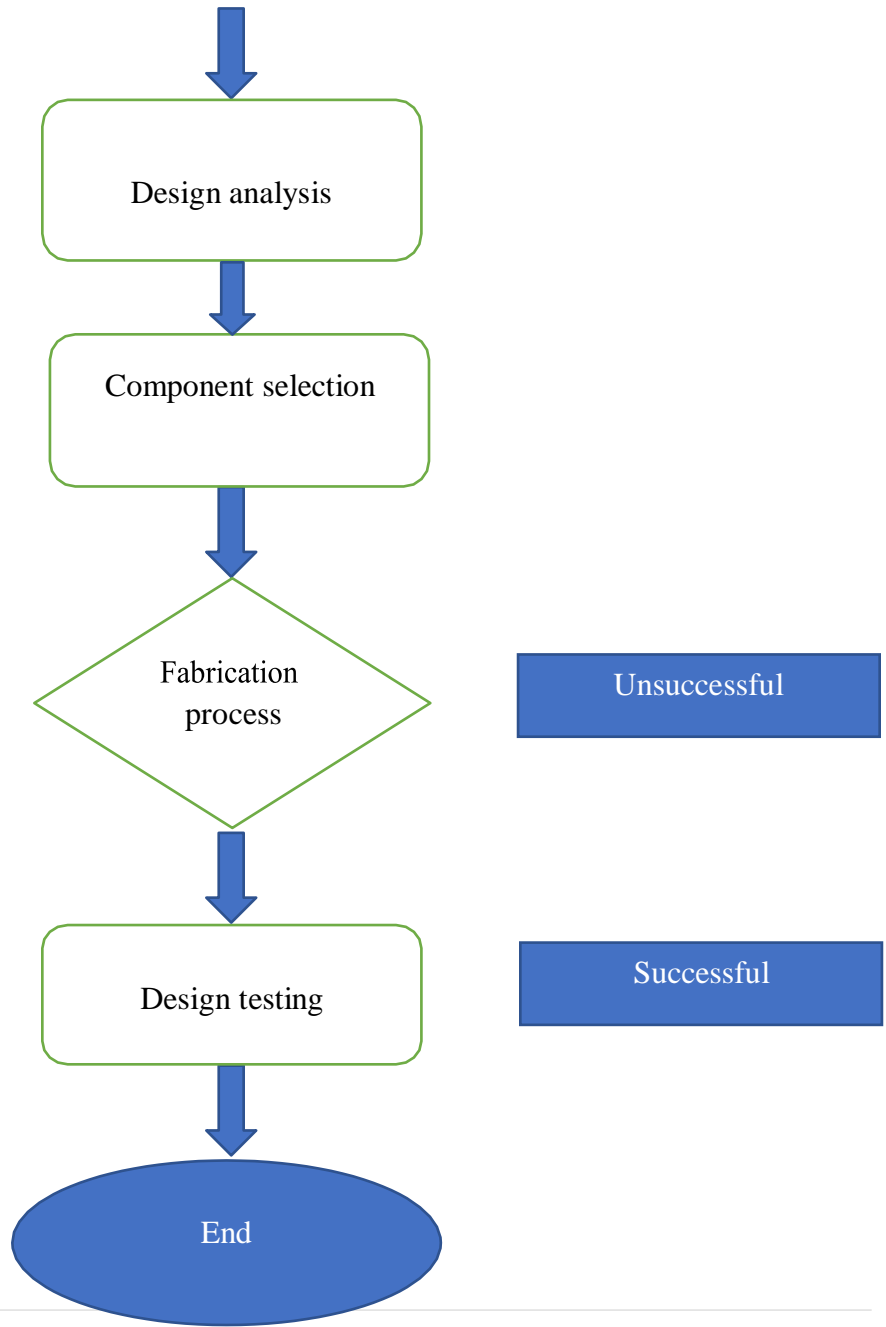

3.3.3 FLOW CHART ON HOW TO WRITE THE REPORT

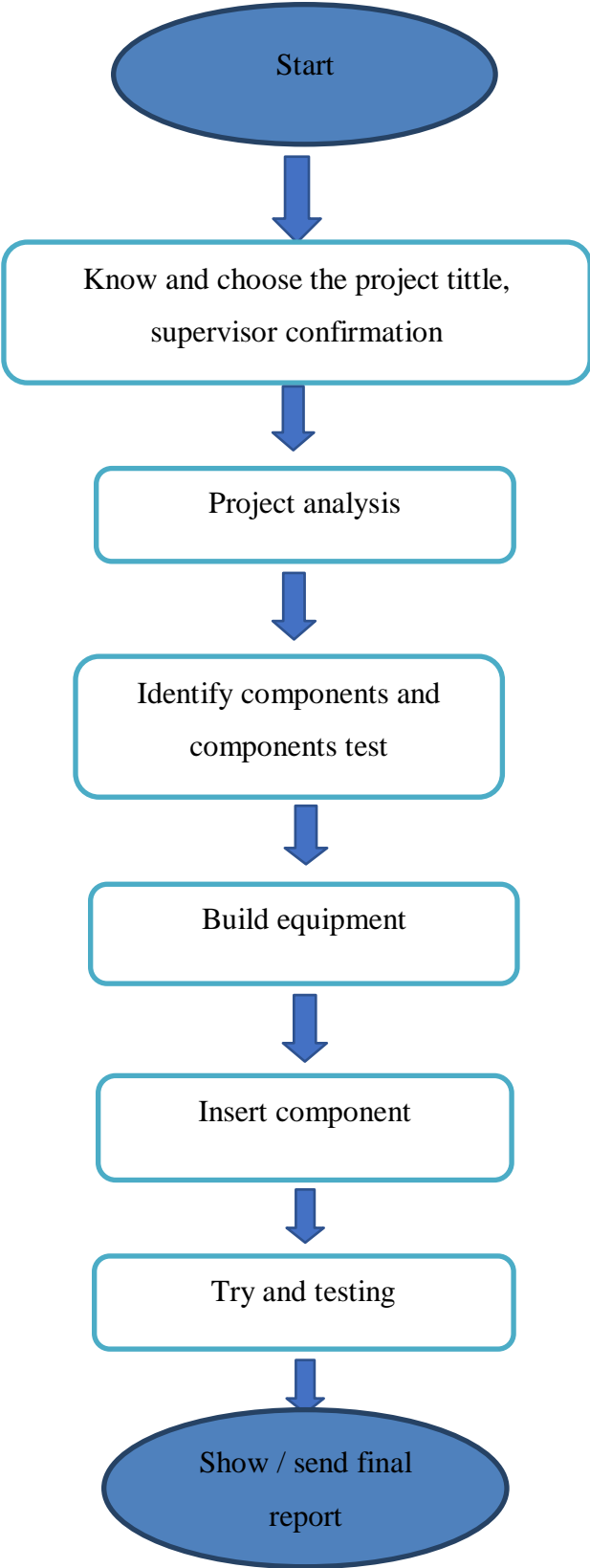

3.4 RESEARCH INSTRUMENT

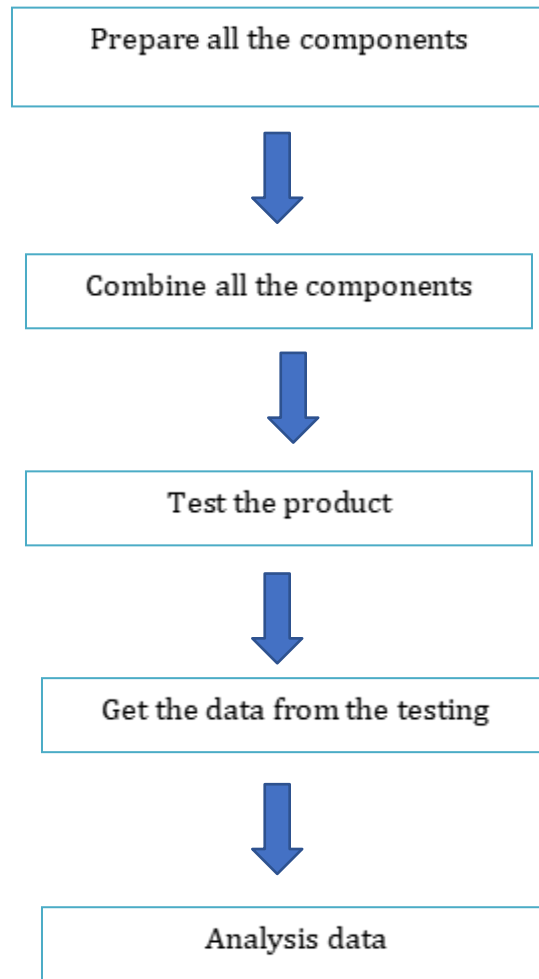

3.5 SAMPLING TECHNIQUE

Sampling methods are classified as either probability or nonprobability. In probability samples, each member of the population has a known non-zero probability of being selected. Probability methods include random sampling, systematic sampling, and stratified sampling. In nonprobability sampling, members are selected from the population in some nonrandom manner. These include convenience sampling, judgment sampling, quota sampling, and snowball sampling. The advantage of probability sampling is that sampling error can be calculated. Sampling error is the degree to which a sample might differ from the population. When inferring to the population, results are reported plus or minus the sampling error. In nonprobability sampling, the degree to which the sample differs from the population remains unknown.

To further our project, we use non-probability sampling. Probability sampling is any sampling method where some elements of population have no chance of selection, or where the probability of selection cannot be accurately determined. It involves the selection of elements based on assumptions regarding the population of interest, which forms the criteria for selection. Hence, because the selection of elements is non-random, non-probability sampling not allows the estimation of sampling errors.

Non-probability sampling includes accidental sampling, quota sampling and purposive sampling. In addition, non-response effects may turn any probability design into a non-probability design if the characteristics of non-response are not well understood, since non-response effectively modifies each element's probability.

3.6 DATA ANALYSIS METHOD

There are several processes on the run during the execution of this project. among others are:

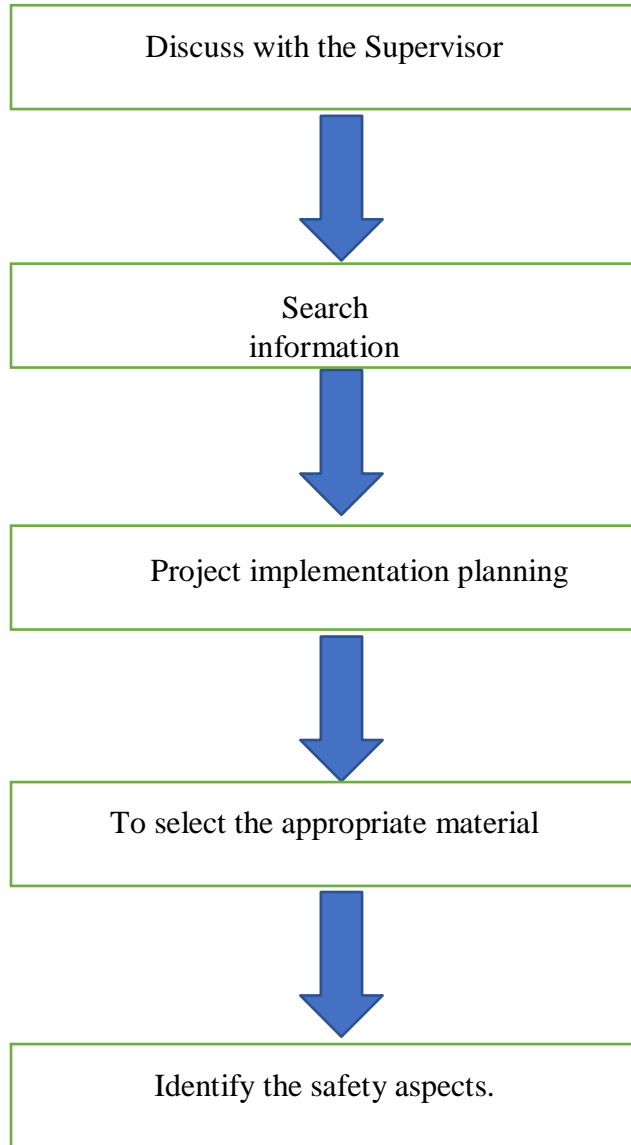

A. DISCUSSION WITH SUPERVISOR

We make this project after we discuss our idea in our final project. Our supervisor gave us her thought and suggestions. Based on the discussion, we gained our knowledge and our imagination on making our project a successful one.

B. RESEARCH FOR INFORMATION

The research for our product was found from Google scholar and Google web. We research about the way our product can be made to function and the connection to make the component in the product to function to its fullest. Besides that, we also use Google form to question our potential users. The questionnaire was sent to the athlete, general workers, students, contractors and farmer/gardeners. Based on the information we get on the questionnaire, we know the things that our users' needs and we use it as a guide to make our project.

C. QUESTIONNAIRE

We are collecting the required information using Google form. The Google form is distributed to the society using media. We distribute it to the athletes, general workers, gardeners/farmers and students in polytechnic to get feedback on the problems encountered, comments or ideas that can be used to produce a product that can enlighten their needs.

3.6.1 THE QUESTIONAIR TO THE RESPONDENT

BORANG SOAL SELIDIK (INOVASI)

assalamualaikum dan salam sejahtera.
Kami pelajar daripada POLITEKNIK SULTAN SALAHUDDIN ABDUL AZIZ SHAH, dari kursus KEJURUTERAAN PERKHIDMATAN BANGUNAN ingin mendapatkan respond tuan/puan/encik/cik tentang produk yang ingin kami inovasikan iaitu Smart Bottle Cooler . Smart Bottle Cooler ini ialah satu botol yang boleh menyejukkan air biasa kepada air sejuk dengan hanya menggunakan botol tersebut tanpa menggunakan bekalan elektrik. Terima Kasih kerana tuan/puan/encik/cik dapat memberi masa untuk menjawab soal selidik ini.

Attachment 1 (PERSONALITY)

Age

- 16-20 years
- 21-25 years
- 26-30 years
- 31-35 years
- 36-40 years
- above 41 years

Gender

- Lelaki
- Perempuan

Jobs / Career

- Farmers / gardeners
- Kontraktor
- Contractor
- Athletes / Sportsmans
- Students
- other

Attachment 2 (KNOWLEGDE)

How much do you take mineral water in one day?

- 1 - 1.5 Liter
- 2 - 2.5 Liter
- 3 - 3.5 Liter
- 4 - 4.5 Liter

Did you know that drinking mineral water is very important to you?

- yes , I know it
- no , I dont know

Do you know that drinking cold water can hydrate your body well?

- Yes
- No

Does the existing bottle cool down and hold off the cold water temperature for a long time?

- Yes
- No

Are you hard to get cold water supply?

- Yes
- No

suggestions for improving the products we provide?

Your answer

3.6.2 THE ANSWER FROM RESPONDENT

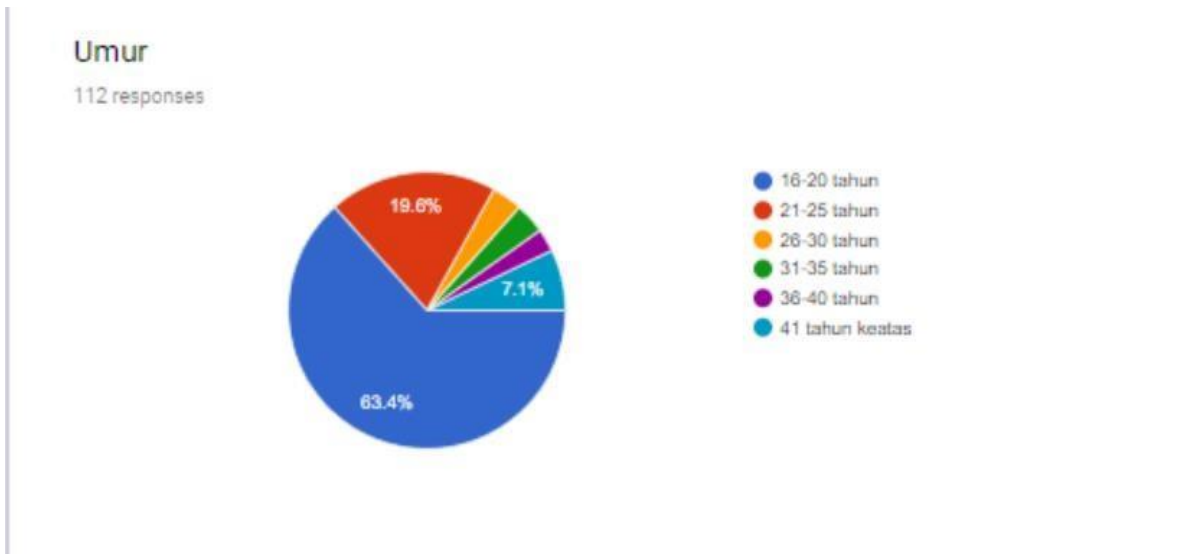
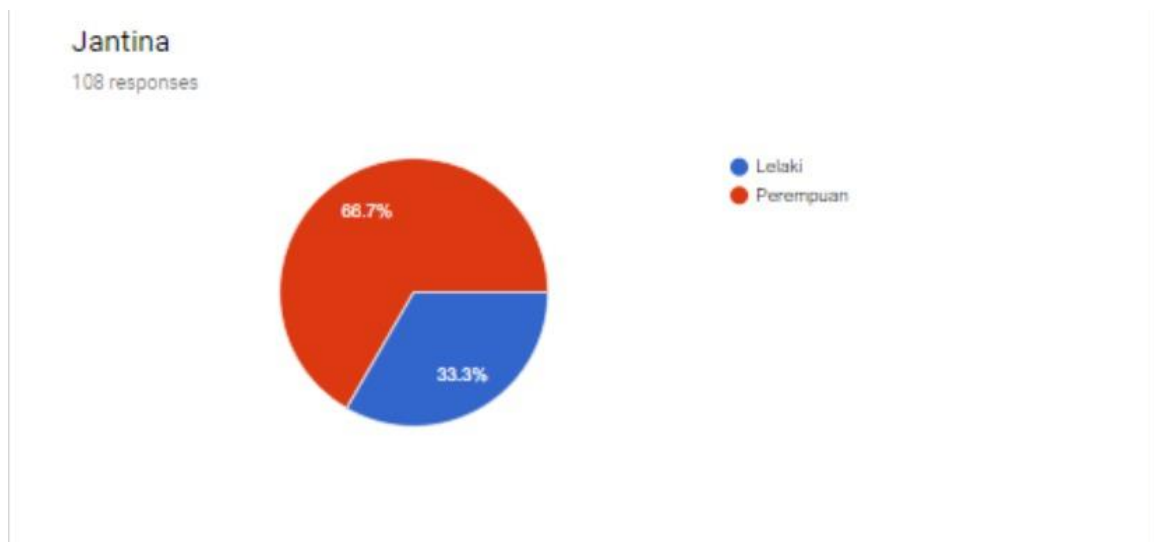

Figure 2.7 : Answer from respondent

Based on our questionnaire, there are 112 respondents. Most of the respondents are at the age of 16 to 20 years old. Followed by respondents at the age of 21 to 25 years old at 19.6%. 7.1% are for the respondents at the age of 41. For respondents at the age of 26 to 40 are the least.

Figure 2.7a



Based on the 108 respondents, 66.7% are female and the rest are male.

Pekerjaan / Kerjaya

111 responses

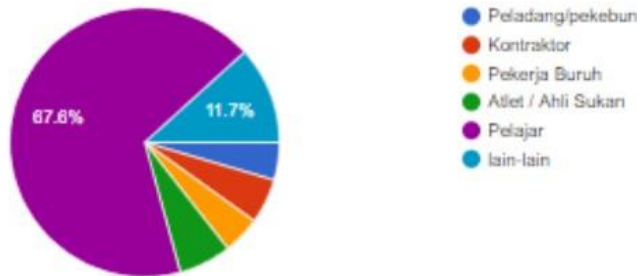

Figure 2.7b

67.6% of students, 11.7% of other occupation of respondents and the other respondents are contractors, gardeners/farmers, general workers and athletes are nearly at the same number.

adakah anda tahu bahawa bekalan air amat penting bagi diri anda ?

111 responses

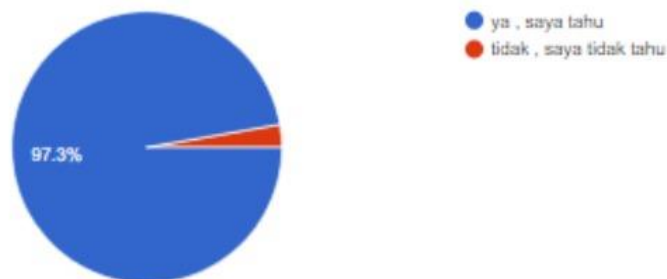

Figure 2.7c

The questionnaire result shows that 97.3% of the respondents know that water resources are important to themselves. And a few of the respondents do not know that water is important to them.

Berapa banyak anda mengambil air mineral dalam satu hari ?

112 responses

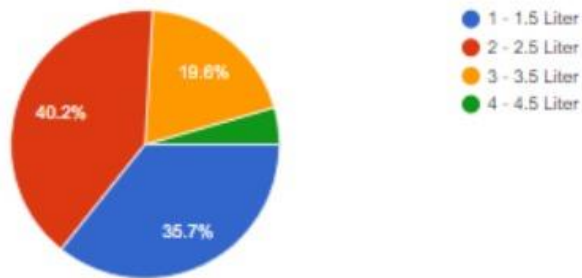

Figure 2.7d

37.5% of the respondent's water intake is in between 1 to 1.5 liters of water for a day. 40.2% of the respondents take 2 to 2.5 liter of water and 19.6% of them take about 3 to 3.5 liter of water daily. And only a few of them take 4 to 4.5 liter of water a day.

adakah anda tahu yang minum air sejuk mendapatkan hidrasi badan yang baik ?

112 responses

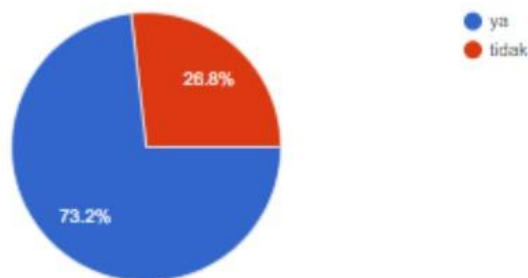

Figure 2.7e

Based on the questionnaire, 62.5% have difficulties in searching for cold water sources and 37.5% of the respondents does not have any difficulties.

cadangan penambahbaikan produk yang kami sediakan ?

45 responses



Figure 2.7f

These are the suggestion suggested by the respondents to improve our product that we invent.

3.7 CONCLUSION

This chapter begins with an introduction then describes the research design employed in this study. Population and sample study are also mentioned before discussing the research methodology used to conduct this research. In collecting data, library and field research are used. For field research, qualitative method is chosen in which group of interviewees are involved in the research procedure. The data that were collected are then analyzed and discussed and the results are displayed.

CHAPTER 4

RESULTS

4.1 INTRODUCTION

Every product has their own results include planned and unplanned results. Outcome, consequence, or conclusion of a problem, probe or experiment after a period of time. This conclusion can be one result, multiple results, or no results. The length of time taken to find a result can vary from less than a second to many years. Results can be achieved by doing multiple testing, research and questionnaire. The results are generally positive improvements to the lives of the beneficiaries. A result is the final consequence of a sequence of actions or events expressed qualitatively or quantitatively. Possible results include advantage, disadvantage, gain, injury, loss, value and victory.

4.2 ANALYSIS & DESCRIPTIVE RESULTS

4.2.1 Temperature taken for first design product

TIME	0 MINUTES	30 MINUTES	1 HOUR	1 HOUR 30 MINUTES	2 HOUR
CAPACITY	TEMPERATURE / °C				
500ml	34	32	30	29	28
1L	34	34	31	31	32

Figure 3.1 : Temperature taken for first design product

4.2.2 Data for latest design product

TIME	0 MINUTES	15 MINUTES	30 MINUTES	45 MINUTES	1 HOUR
CAPACITY	TEMPERATURE/°C				
800ml	32	27	25.3	23.7	22.4

Figure 3.2 : Temperature taken for latest design product

4.3 ANALYSIS & EMPIRICAL RESULTS

Empirical implies that the information is based on experience, and **data** is information we gather about something. Thus, the information acquired by scientists through experimentation and observation is called **empirical data**. Gathering empirical data is an essential part of the scientific process. After we planned the product, we started the process with collecting data from websites, books, users and specialists. For the documentation, we distributed questionnaire to our target market. After that, we made the analysis of data.

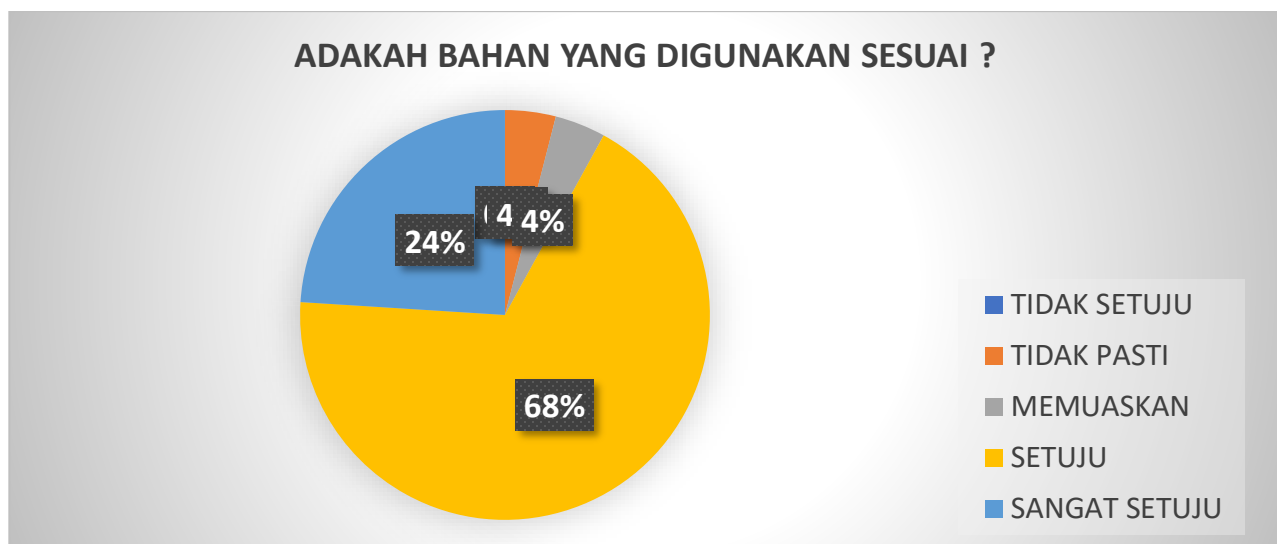

Figure 3.3 : Answer from respondent

ADAKAH SUSUN ATUR KELENGKAPAN ELEKTRONIK DAN AKSESORI MEMUDAHKAN PENGGUNA?

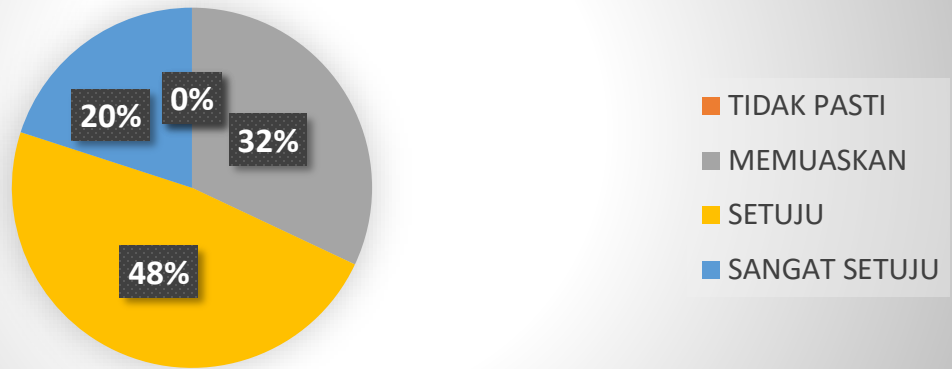

Figure 3.3a

ADAKAH BATERI YANG DIGUNAKAN SESUAI?



Figure 3.3b

KAPASITI AIR SESUAI DENGAN KEPERLUAN PENGGUNA



Figure 3.3c

REKABENTUK SMART BOX COOLER MENEPATI KEHENDAK PENGGUNA



Figure 3.3d

FUNGSI PRODUK INI BERSESUAIAN DENGAN KEHENDAK PENGGUNA PADA MASA KINI



Figure 3.3e

SAIZ PRODUK SESUAI UNTUK DIBAWA KE MANA-MANA



Figure 3.3f

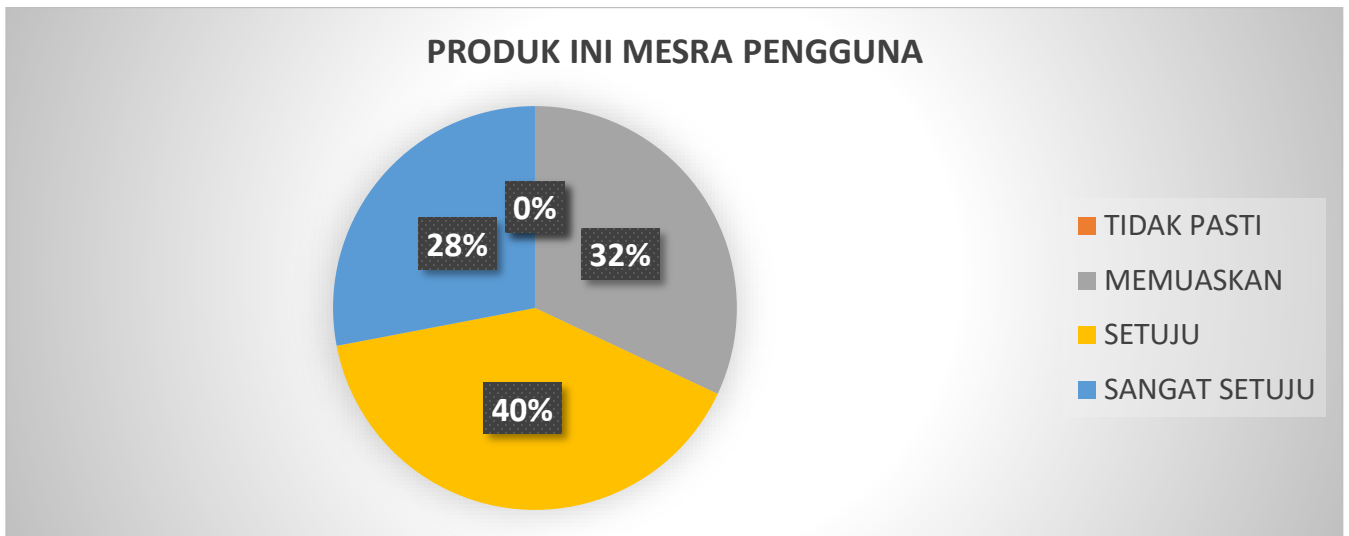

Figure 3.1g

4.4 CONCLUSION

Every result is being analysis to ensure that we produce a product that can be used by the users comfortably. We always do our product based on what users want and need. The result that we get is based on the questionnaire that distributed to the users. The priority of our product is followed by our target market. All the results are being recorded to keep on track on our product needs.

CHAPTER 5

DISCUSSION AND CONCLUSION

5.1 INTRODUCTION

In this chapter, we interpret the results from data analysis from chapter 4 based on the planned research hypothesis. Descriptions also explain unexpected scientific results, reasonable international explanations of the findings and limitations or limitations of the study. Descriptions are also relevant to the discussion of how the data obtained is related to the research question or topic of study. The description also links the results of the study with the previous studies by previous researchers in the review of the work. The research questions and the conclusions of the study are presented in the conclusions section of the report.

5.2 DISCUSSION

The discussion is made by us in order to make sure that the product is in good quality. Every product must going through a few discussion to gain an accurate result.





Figure 4.1 : Discussion with team

We were discuss about improvement of the product and in progress of finishing the report in chapter 4 and chapter 5.

5.3 CONCLUSION

The 'Smart Box Cooler' project was designed and manufactured to meet the requirements in the Diploma in Building Services syllabus. During the process of making this product, we have a wealth of knowledge of the field in expertise we are working on. Collaboration from lecturers and experts involved in the development of this Smart Box Cooler product is such a big help to us.

With this project, it will provide consumers within time, energy and money. The objective of this product is to make it easier for consumers to find a source of cold water and to produce a product that can cool water and food other than using the refrigerator.

At the end of this project, we hope it brings benefits to consumers. Although it is a innovation product, the benefits will be feel by everyone.

5.4 SUGGESTION

To address the weaknesses of this project, several suggestions have been made:

- i. Add security features to ensure the security of your users.
- ii. Physical design and exterior design that are more attractive to buyers.
- iii. Adjustable box size to make it easier for users and the addition of pads behind the product

5.5 CHAPTER SUMMARY

This chapter explains the problems encountered & discusses before making a decision as the project progresses. In addition, safety features and product design also play an important role as it is the first consumer view of our product. After that, finished projects need to be identified for improvement process in order to produce better quality products.

REFERENCES

- annex. (2013, august 26). *mid city steel*. Retrieved march 10, 2019, from mid city steel.ma: <https://midcitysteel.com/the-amazing-abilities-and-advantages-of-stainless-steel/>
- ashish. (2016, march 11). *science ABC*. Retrieved from scienceabc.com: <https://www.scienceabc.com/innovation/how-does-a-refrigerator-work-working-principle.html>
- bowney, s. (2017, may 25). *getecna industrial*. Retrieved march 16, 2019, from getec : www.getecna.com/active-heat-sinks-passive-heat-sinks-whats-difference/
- fier, a. (2008, june 1). *safety and health magazine*. Retrieved march 17, 2019, from safetyandhealthmagazine.com: <https://www.safetyandhealthmagazine.com/articles/ensuring-workers-drink-enough-water-2>
- hurly, a. (2016, february 24). *kitchn*. Retrieved from thekitchn.com: <https://www.thekitchn.com/a-brief-history-of-bottled-water-228642>
- l., m. (2017, august 14). *scientific american*. Retrieved march 10, 2019, from scientific american.inc: www.scientificamerican.com/article/why-doesnt-stainless-steel/
- laskey, j. (2015, february 16). *everyday health*. Retrieved from www.everydayhealth.com: <https://www.everydayhealth.com/water-health/water-body-health.aspx>
- millar, a. (2017, august 30). *netdoctor*. Retrieved from www.netdoctor.co.uk: <https://www.netdoctor.co.uk/healthy-living/a28759/plastic-water-bottle-bad-for-health/>
- millar, c. (2007, august 1). *waste 360*. Retrieved from waste360.com: https://www.waste360.com/recycling_and_processing/waste_glass_containers_4
- ometto, s. (2017, august 24). Retrieved march 11, 2019, from carel industries S.p.A: https://www.carel.com/blog;jsessionid=9916945477899629FAB95AB638ADBDC_TAG=BOTTLE+COOLERS
- seana. (2014, november 12). *free letics*. Retrieved march 17, 2019, from freeletics.com: <https://www.freeletics.com/en/blog/posts/much-athlete-drink/>
- seikan, t. (2016, may 8). *toyo seikan co.,ltd*. Retrieved march 10, 2019, from toyo-seikan.co.jp: <https://toyo-seikan.co.jp/e/technique/plasticbottle/kind>
- Snyder, J. A., & Wechsler, R. (1980). Plastic Bottle.
- staff, m. c. (2017, september 6). *mayo clinic*. Retrieved march 17, 2019, from mayo clinic.org: <https://www.mayoclinic.org/healthy-lifestyle/nutrition-and-healthy-eating/in-depth/water/art-20044256>
- torrone, p. (2006, december 14). *maker media*. Retrieved from makezine.com: <https://makezine.com/2006/12/14/how-long-in-the-freezer-d/>
- Vermeerbergen, L., & Flamand , G. (1972). bottle.

wyeth, n. (1990, July 09). *Los Angeles Times*. Retrieved from articles.latimes:
http://articles.latimes.com/1990-07-09/news/mn-218_1_plastic-soda-bottle

Anne Marie Helmenstine, P. (28 September, 2018). *How Much of Your Body Is Water?* . Retrieved from Thought Co: <https://www.thoughtco.com/how-much-of-your-body-is-water-609406>

Britannica, T. E. (16 February, 2016). *Cooling System Engineering*. Retrieved from Britannica:
<https://www.britannica.com/technology/cooling-system>

Bumgardner, W. (23 September, 2018). *Is Drinking Cold Water During or After Exercise Good or Bad?* . Retrieved from Very Well Fit: <https://www.verywellfit.com/is-drinking-cold-water-when-exercising-good-or-bad-3435421>

Heat Sink . (2019). Retrieved from Techopedia: <https://www.techopedia.com/definition/2211/heat-sink>

McIntosh, J. (16 July, 2018). *Fifteen Benefits of Drinking Water*. Retrieved from Medical News Today: <https://www.medicalnewstoday.com/articles/290814.php>

Radian. (2011). *What is a Heat Sinks*. Retrieved from Radian Heat Sinks:
<https://www.radianheatsinks.com/heatsink/>

Rose, B. (1 May, 2018). *How to Select a Peltier Module*. Retrieved from Cui :
<https://www.cui.com/blog/how-to-select-a-peltier-module>

Vu, B. (25 February, 2019). *The Best Water Bottles*. Retrieved from Your Best Digs:
<https://www.yourbestdigs.com/reviews/best-water-bottle/#the-22-finalists>

Wechsler, J. A. (9 March, 2000). *Plastic Bottle*. Retrieved from Patent Google:
<https://patents.google.com/patent/US4318489A/en>

Wyeth, N. (9 July, 1990). *Invented Plastic Soda Bottle*. Retrieved from Los Angeles Times:
http://article.latimes.com/1990-07/news/mn-218_1_plastic-soda-bottle

Alvin A. Babb, 1. W., & Don R. Babb. (1995). *United States Patent Patent No. 5,406,808*.

B. Baudouy, H.-M. C. (2015). The influence of Thomson effect in the performance optimization of a two stage thermoelectric cooler. *Cryogenics*, 72, 57-64.

Back, W., Landa, E., & Meeks, L. (1995). *Bottled Water, Spas, and Early Years of Water Chemistry (Groundwater Volume 33, Issue 4 ed.)*.

Ferrier, C. (2001). Bottled Water: Understanding a Social Phenomenon. *AMBIO: A J. of the Human Environment*, 30(2), 118-119.

Francisco, A. (2019, January 19). *Different Types of Water Bottles and How to Choose From Them*. Retrieved from top5.com: <https://www.top5.com/different-types-of-water-bottles-and-how-to-choose/>

Hall, N. (2013, October 17). "A Brief History of Bottled Water in America". . *Great Lakes Law*.

How Does Air Conditioning Work? (2017, February 28). Retrieved from Howard Air:

<https://howardair.com/how-does-air-conditioning-work/>

Jessica Buschmann, R. (2014, august 20). *Athletes and Hydrating: What You Need to Know*. Retrieved from Nationwide Children's: <https://www.nationwidechildrens.org/family-resources-education/700childrens/2014/08/athletes-and-hydrating-what-you-need-to-know>

Alvin A. Babb, 1. W., & Don R. Babb. (1995). *United States Patent Patent No. 5,406,808*.

Back, W., Landa, E., & Meeks, L. (1995). *Bottled Water, Spas, and Early Years of Water Chemistry (Groundwater Volume 33, Issue 4 ed.)*.

Ferrier, C. (2001). Bottled Water: Understanding a Social Phenomenon. *AMBIO: A J. of the Human Environment*, 30(2), 118-119.

Seth, R. (2012, june 14). *Twisted Cold Water* . Retrieved from Yanko Design - Modern Industrial Design News: <https://www.yankodesign.com/2012/06/14/twisted-cold-water/>

Vu, B. (2019). *What bottle type is best for you?* Retrieved from YourBestDigs: <https://www.yourbestdigs.com/reviews/best-water-bottle/>

- Kris Gunnars, B. (2018, June 20). *How Much Water Should You Drink Per Day?* Retrieved from healthline: <https://www.healthline.com/nutrition/how-much-water-should-you-drink-per-day#section2>
- Randall A. Harris, 8. C. (2000). *United States Patent No. 6,065,303* .
- Rong, X. G., & Fa, B. T. (2013, October 17). *"Primitive-Aged Drinking Vessels"*. Retrieved from Grandiose Survey of Chinese Alcoholic Drinks and Beverages. Jiangnan University.
- Seth, R. (2012, June 14). *Twisted Cold Water* . Retrieved from Yanko Design - Modern Industrial Design News: <https://www.yankodesign.com/2012/06/14/twisted-cold-water/>
- types of batteries* . (n.d.). Retrieved from The rechargeable battery association: <http://www.prba.org/battery-safety-market-info/types-of-batteries/>
- Vu, B. (2019). *What bottle type is best for you?* Retrieved from YourBestDigs: <https://www.yourbestdigs.com/reviews/best-water-bottle/>

APPENDIX

I. GANTT CHART

II. QUESTIONNAIRE



DIPLOMA KEJURUTERAAN PERKHIDMATAN BANGUNAN

JABATAN KEJURUTERAAN AWAM, POLITEKNIK SULTAN SALAHUDDIN
ABDUL AZIZ SHAH, SHAH ALAM.

PENYELIDIKAN RESPONDEN PROJEK TAHUN AKHIR

Penyelidik: Hanis Nabila Binti Mohd Shaari (08DPB17F1159)

Nurfitriyani Binti Mohd Aris (08DPB17F1117)

Eva Maria Joel Jenet (08DPB17F1201)

Farah Azra Dayana Binti Arifin (08DPB17F1147)

Penyelia: Puan Rosida Binti Ahmad

Pengenalan: Tajuk penyelidikan ini ialah merekabentuk “**Smart Bottle Cooler**” yang merupakan inovasi dari meja sedia ada. Borang kaji selidik produk akhir ini dilakukan untuk mendapatkan maklumbalas setelah segala perlaksanaan awal dilakukan serta menerima penambahbaikan daripada aspek rekaan, fungsi, bahan dan sebagainya sekiranya perlu dari pihak industri luar. Sila jawab semua soalan dengan lengkap berdasarkan arahan yang diberi. Kerjasama daripada pihak tuan/puan amatlah dihargai. Sekian, terima kasih.

Bahagian A: Kajian Demografi

Sila tandakan (✓) jawapan yang paling sesuai dengan setiap soalan.

1. Jantina

Lelaki
Perempuan

2. Umur

11-20 Tahun
21-30 Tahun
31-40 Tahun
41-50 Tahun
50 keatas

3. Pekerjaan

Bahagian B: Kajian Produk Sedia Ada.

Sila tandakan (✓) jawapan yang paling sesuai dengan setiap soalan.

Bil.	Soalan	Ya	Tidak
1	Botol minuman sedia ada mempunyai multifungsi apabila digunakan.		
2	Botol yang anda miliki sekarang mudah dikendalikan ketika digunakan.		
3	Botol anda menepati ciri-ciri keselamatan untuk semua peringkat umur.		
4	Jenis bahan yang digunakan sesuai dengan produk botol minuman.		
5	Aksesori yang diletakkan pada botol memenuhi keperluan pengguna.		
6	Kapasiti air yang disediakan memenuhi keperluan seharian anda.		

Bahagian C: Kajian Rekabentuk

Sila **tuliskan** pada pilihan jawapan anda mengikut skala yang telah ditetapkan.

1 Tidak setuju	2 Tidak pasti	3 Memuaskan	4 Setuju	5 Sangat setuju
-------------------	------------------	----------------	-------------	--------------------

Bil	Soalan	Skala				
1	Material dan bahan					
	Adakah bahan yang digunakan sesuai ?					
	Adakah susun atur kelengkapan elektronik & aksesori memudahkan pengguna ?					
2	Ergonomik dan Rekabentuk					
	Adakah bateri yang digunakan sesuai?					
	Kapasiti air sesuai dengan keperluan pengguna.					
	Rekabentuk Smart Bottle Cooler menepati kehendak pengguna.					
	Fungsi produk ini bersesuaian dengan kehendak pengguna pada masa kini.					
	Saiz produk sesuai untuk dibawa ke mana-mana.					
	Produk ini mesra pengguna.					

Bahagian D: Kajian Inovasi Penambahbaikan

Sila **lampirkan** jawapan dan cadangan penambahbaikan yang boleh kami lakukan selepas ini.

.....

.....

.....

.....

.....

Kerjasama pihak tuan/puan amatlah kami hargai.

Bahagian E: Kajian Pengesahan

Sila **lengkapkan** untuk pengesahan dan bukti. Sekian, Terima kasih

Tandatangan

Cop syarikat (Jika ada)

III . COSTING

NO.	ITEM	QUANTITY	PRICE	AMOUNT
1	DVE DSA-60W-12112060 DC12V 5A 00101542	1	45	45
2	PELTIER MODULE (TEC1-12703) 547001105)	1	30	30
3	7/0 2MM CABLE (100M) MIX 061014012-2	1	0.8	0.8
4	ZIP 4PCS C0940 B-38-12/360	1	1.79	1.79
5	KCD1-101A 2PIN O/F SW(6A) MSR-550011217	1	1.5	1.5
6	3510S DC12V 1 1/2" 35X35X10MM 151010181	1	7.5	7.5
7	DC SOCKET 2MM WITH SCREW T9 451002231	1	1.4	1.4
8	PELTIER MODULE (TEC1-12703) 547001100	1	45	45
9	YM2404PKS1 1 1/2" DC24V 151010154	1	7	7
10	HEATSINK 28X28X8 (BLACK)	1	2	2
11	12032S SL DC12V FAN (ROUND) DC 151010190	1	34	34
12	KINGS KSS36-120-3000 DC12V 3A 001010541	1	37	37
13	HEAT SHRINK TUBE 3.0MM (200M) 571051005	1	0.9	0.9
14	SHOES BOX 8643	1	7.45	7.45
15	DIGITAL THERMOMETER ST-1A	1	25	25
16	MALAYSIA 13A POWER CORD 061007025	1	10.5	10.5
17	25155730 LED STRIPE (BLUE) 341001119	1	1.7	1.7
18	STRERCH SELF-ST	1	5.9	5.9
19	PLAT	1	20	20
				284.44

IV . LIST OF COMPONENTS

NO.	ITEM	QUANTITY
1	DVE DSA-60W-12112060 DC12V 5A 00101542	1
2	PELTIER MODULE (TEC1-12703) 547001105)	1
3	7/0 2MM CABLE (100M) MIX 061014012-2	1
4	ZIP 4PCS C0940 B-38-12/360	1
5	KCD1-101A 2PIN O/F SW(6A) MSR-550011217	1
6	3510S DC12V 1 1/2" 35X35X10MM 151010181	1
7	DC SOCKET 2MM WITH SCREW T9 451002231	1
8	PELTIER MODULE (TEC1-12703) 547001100	1
9	YM2404PKS1 1 1/2" DC24V 151010154	1
10	HEATSINK 28X28X8 (BLACK)	1
11	12032S SL DC12V FAN (ROUND) DC 151010190	1
12	KINGS KSS36-120-3000 DC12V 3A 001010541	1
13	HEAT SHRINK TUBE 3.0MM (200M) 571051005	1
14	SHOES BOX 8643	1
15	DIGITAL THERMOMETER ST-1A	1
16	MALAYSIA 13A POWER CORD 061007025	1
17	25155730 LED STRIPE (BLUE) 341001119	1
18	STRERCH SELF-ST	1
19	PLAT	1