

SULIT



**BAHAGIAN PEPERIKSAAN DAN PENILAIAN
JABATAN PENDIDIKAN POLITEKNIK
KEMENTERIAN PENDIDIKAN TINGGI**

JABATAN KEJURUTERAAN ELEKTRIK

PEPERIKSAAN AKHIR

SESI JUN 2016

**EJ 501: PROGRAMMABLE LOGIC CONTROLLER(PLC) &
AUTOMATION**

TARIKH : 24 OKTOBER 2016

MASA : 2.30 PM – 4.30 PM (2 JAM)

Kertas ini mengandungi **SEPULUH (10)** halaman bercetak.

Bahagian A: Struktur (10 soalan)

Bahagian B: Esei (3 soalan)

Dokumen sokongan yang disertakan : Tiada

JANGAN BUKA KERTAS SOALAN INI SEHINGGA DIARAHKAN

(CLO yang tertera hanya sebagai rujukan)

SULIT

SECTION A : 40 MARKS

BAHAGIAN A : 40 MARKAH

INSTRUCTION:

This section consists of TEN (10) structured questions. Answer ALL questions.

ARAHAN:

Bahagian ini mengandungi SEPULUH (10) soalan berstruktur. Jawab SEMUA soalan.

CLO1
C2

QUESTION 1
SOALAN 1

Describe TWO (2) functions of a valve and a solenoid as an actuator.

Jelaskan DUA (2) fungsi injap dan solenoid sebagai penggerak.

[4 marks]

[4 markah]

CLO1
C2

QUESTION 2
SOALAN 2

Based on Figure A1, briefly explain the operation of relay.

Berdasarkan pada *Rajah A1*, terangkan secara ringkas operasi geganti.

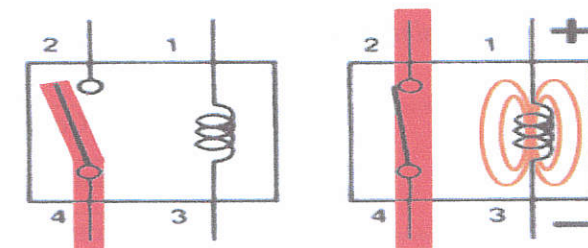

Diagram A1 / *Rajah A1*

[4 marks]

[4 markah]

CLO1
C2

QUESTION 3
SOALAN 3

Sensors allow a PLC to detect the state of a process. Briefly explain the function of Optical sensors, *retro reflective* type by using a suitable diagram.

Penderia menyebabkan PLC dapat mengesan keadaan sesuatu proses. Terangkan dengan ringkas fungsi sensor jenis Photoelektrik jenis retro reflective dengan bantuan gambarajah yang sesuai.

[4 marks]
[4 markah]

CLO1
C2

QUESTION 4
SOALAN 4

Draw and label a basic PLC structure with a suitable diagram.
Lukis dan labelkan struktur asas PLC.

[4 marks]
[4 markah]

CLO1
C3

QUESTION 5
SOALAN 5

Draw the PLC connection wiring for the component in the table below.
Lukiskan litar penyambungan PLC bagi komponen dalam jadual di bawah.

Quantity	Component
1 nos	Lamp 24Vdc
1 nos	Motor 24Vdc
1 nos	Proximity sensor
1 nos	

Figure 5 / Rajah 5

[4 marks]
[4 markah]

CLO2
C3

QUESTION 6
SOALAN 6

Based on ladder diagram in **Figure 6** below, list the mnemonic code.

*Berdasarkan rajah tangga di **Rajah 6** di bawah, senaraikan kod mnemonic.*

[4 marks]
[4 markah]

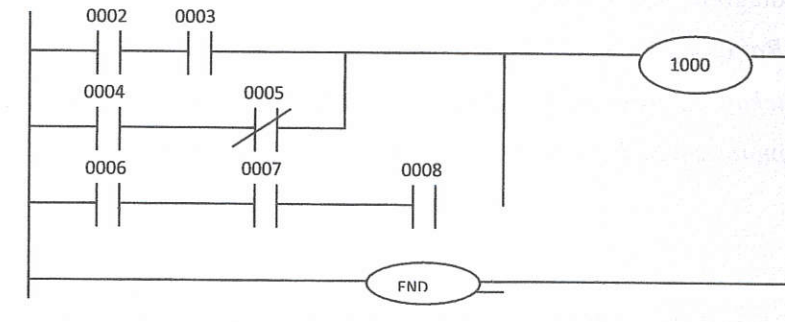

Figure 6/Rajah 6

CLO2
C3

QUESTION 7
SOALAN 7

Referring to **Figure 7**, explain the function of SET and RESET.

*Merujuk kepada **Rajah 7**, terangkan fungsi SET dan RESET.*

[4 marks]
[4 markah]

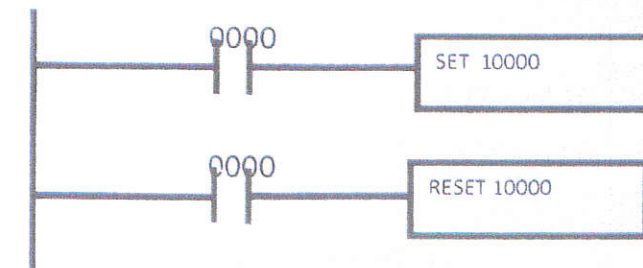

Figure 7 / Rajah 7

CLO2
C3**QUESTION 8**
SOALAN 8

Figure A(8) shows a simple lamp circuit. Actuation of a push button (S1) is to cause a lamp (H1) to be switched ON. The lamp is to be illuminated as long as the push button is actuated. List and assign the operand bit of input/output devices. Then draw the ladder diagram for the circuit.

Rajah A(8) menunjukkan sebuah system litar lampu yang mudah. Jika punat tekan (S1) di tekan, ia akan menyebabkan lampu (H1) menyala. Lampu akan sentiasa menyala selagi punat tekan di tekan. Lukiskan rajah tangga litar ini.

[4 marks]

[4 markah]

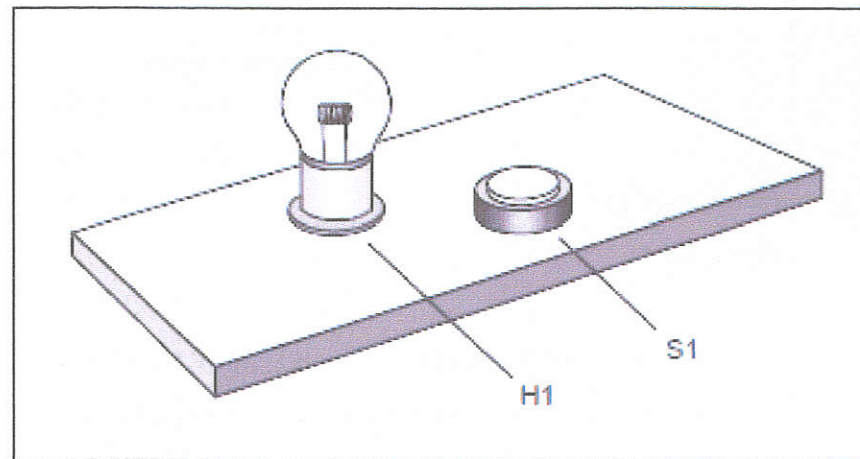

Figure A(8) / Rajah A(8)

CLO1
C3**QUESTION 9**
SOALAN 9

List the criteria that need to be considered when selecting PLC to be placed in a cabinet.

Senaraikan kateria yang perlu dipertimbangkan semasa membuat pemilihan PLC yang akan ditempatkan dalam kabinet.

[4 marks]

[4 markah]

CLO1
C3**QUESTION 10**
SOALAN 10

List **FOUR (4)** causes of internal PLC damage.

Senaraikan EMPAT (4) penyebab kerosakan pada bahagian dalam PLC.

[4 marks]

[4 markah]

SECTION B : 60 MARKS**BAHAGIAN B : 60 MARKAH****INSTRUCTION:**

This section consists of **THREE (3)** essay questions. Answer **ALL** questions.

ARAHAN:

Bahagian ini mengandungi TIGA (3) soalan esei. Jawab SEMUA soalan.

CLO1
C2**QUESTION 1(a)**
SOALAN 1(a)

Describe **TWO (2)** differences between relay and contactor.

Jelaskan DUA (2) perbezaan diantara relay dan penyentuh.

[4 marks]

[4 markah]

CLO1
C2**QUESTION 1(b)**
SOALAN 1(b)

With the aid of an appropriate diagram, explain the contactor operation.

Dengan bantuan gambarajah yang bersesuaian, terangkan kendalian penyentuh.

[10 marks]

[10 markah]

CLO1
C2

QUESTION 1(c)

SOALAN 1(c)

Explain the using functions on the following sensors:

Terangkan fungsi pergerakan bagi penderia kegunaan penderia berikut:

- i) Inductive sensor / *Inductive sensor*
- ii) Capacitive sensor / *Capacitive sensor*
- iii) Ultrasonic sensor / *Ultrasonic sensor*

[6 marks]

[6 markah]

QUESTION 2

CLO1
C2

SOALAN 2

- (a) Identify **FOUR (4)** advantages using of PLC.

Kenalpasti EMPAT (4) kelebihan menggunakan PLC.

[4 marks]

[4 markah]

- (b) **Figure B2 (b)** below show the timing diagram to operation three output. Based on an operation:

Rajah B2 (b) di bawah menunjukkan rajah pemasa bagi kendalian tiga keluaran.

Berdasarkan kepada kendalian tersebut:

- i. Draw the symbol of TIMER and list the set value (SV) and number of TIMER (N).

Lukiskan simbol PEMASA dan senaraikan nilai set (SV) dan nombor PEMASA (N)

- ii. Transfer the timing diagram operation to the ladder diagram and mnemonic code.

Pindahkan kendalian rajah pemasa kepada gambarajah tangga dan kod mnemonic.

[16 marks]

[16 markah]

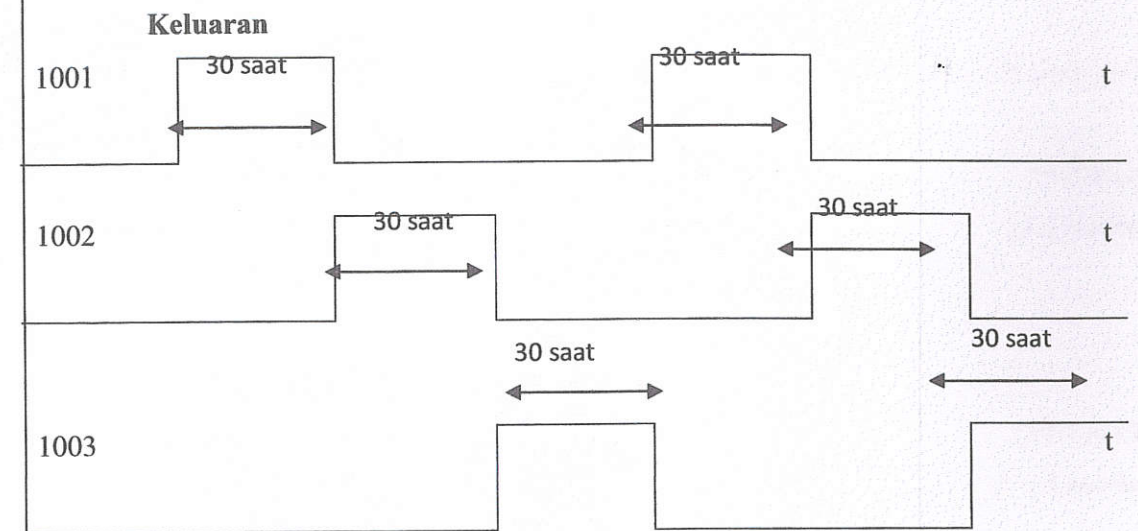

Figure B2(b)/Rajah B2(b)

QUESTION 3

SOALAN 3

- (a) **Figure B3** below shows a quiz program that is using First-in Priority Circuit concept.

Read and understand the sequential operation and the system layout given. Then answer the following questions.

Rajah B3 di bawah menunjukkan program quiz menggunakan konsep kawalan jujukan yang mudah. Baca dan fahami jujukan operasi yang diberikan. Kemudian jawab soalan-soalan yang diberi.

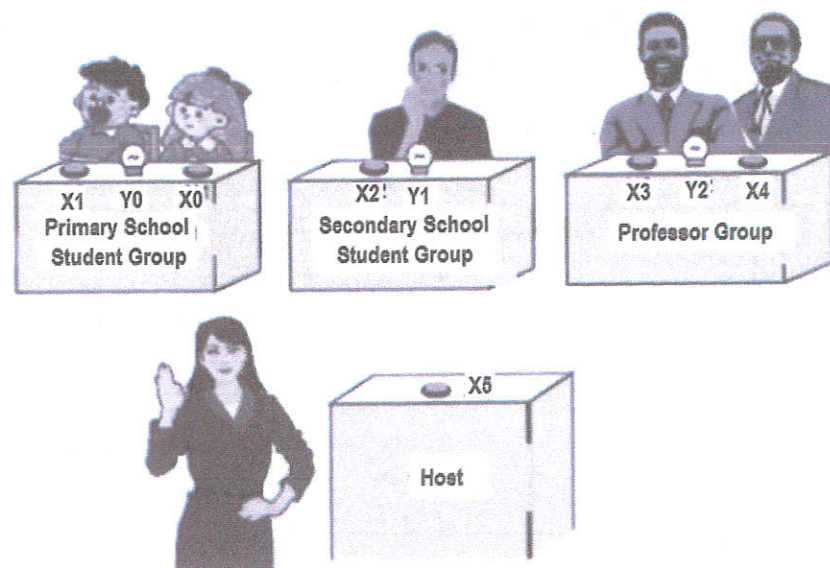

Figure B3 / Rajah B3

Control Purpose:

- There are 3 groups participating in the quiz program: primary school student, secondary school students, and professors.
- If they want to get the chance of answering the question from the host, they must press the answer button (X0, X1, X2, X3, and X4) on their table first. Other groups pressing will be invalid if other group gets the chance successfully.
- There are 2 answer buttons for the primary school students group and professor group, which are X0 and X1 and X3 and X4 respectively. The secondary school group has only 1 answer button which is X2.
- In order to give preferential treatment to primary school students group, Y0 lamp will be ON if one of X0 or X1 is pressed. However, in order to limit the professor group, Y2 lamp will be ON when X3 and X4 are pressed at the same time. For the secondary school student group, Y1 lamp will be ON when X2 is pressed.
- If the host presses reset button X5, Y0, Y1 and Y2 will be OFF.

CLO1
C3

- (i) List and assign the operation bit for the input and output devices used.
Senaraikan dan tentukan bit operasi bagi peranti-peranti masukan dan keluaran yang digunakan.

[4.5marks]

[4.5 markah]

CLO2
C3

- (ii) Draw the ladder diagram of the system.
Lukiskan gambarajah tangga sistem.

[10.5 marks]

[10.5 markah]

CLO1
C3

- (b) List FIVE (5) preventive maintenance works that should be done to the system that is using PLC.

Senaraikan LIMA (5) kerja penyelenggaraan pencegahan yang perlu dilakukan dalam system menggunakan PLC.

[5 marks]

[5 markah]

SOALAN TAMAT